

# Table of Contents

Introduction .....	2
Distribution Systems .....	4
Panelboards .....	6
Overcurrent Protective Devices .....	11
Panelboard Construction .....	16
Types Of Panelboards .....	25
Individual Overcurrent Protection .....	30
Power Supply Systems.....	35
Service Entrance Panelboards .....	38
Panelboard Grounding .....	41
Ground Fault Protection .....	46
Panelboard Ratings .....	48
S1, S2, And SE Lighting Panelboards .....	52
Transient Protection System (TPS) .....	57
S4 And S5 Power Panelboards .....	61
F1 And F2 Fusible Panelboards .....	63
Telephone And Equipment Panelboards .....	68
Seismic Rated Panelboards .....	69
Accessories .....	70
Catalog Numbers .....	73
Information Needed To Order Panelboards.....	76
Review Answers .....	78
Final Exam .....	79

# Introduction

Welcome to another course in the STEP 2000 series, **Siemens Technical Education Program**, designed to prepare our distributors to sell Siemens Energy & Automation products more effectively. This course covers **Panelboards** and related products.

Upon completion of **Panelboards** you will be able to:

- Explain the role of panelboards in a distribution system
- Define a panelboard according to the National Electrical Code
- Distinguish between a lighting and appliance panelboard versus a power and distribution panelboard
- Explain the need for circuit protection
- Identify various components of a Siemens panelboard
- Distinguish between a main breaker and main lug only panelboard
- Identify various power supply systems
- Explain the use of panelboards used as service-entrance equipment
- Describe the proper grounding techniques of service entrance and downstream panelboards
- Identify various ratings of Siemens panelboards
- Identify panelboard accessories

This knowledge will help you better understand customer applications. In addition, you will be able to describe products to customers and determine important differences between products. You should complete **Basics of Electricity** and **Molded Case Circuit Breakers** before attempting **Panelboards**. An understanding of many of the concepts covered in **Basics of Electricity** and **Molded Case Circuit Breakers** is required for **Panelboards**.

If you are an employee of a Siemens Energy & Automation authorized distributor, fill out the final exam tear-out card and mail in the card. We will mail you a certificate of completion if you score a passing grade. Good luck with your efforts.

I-T-E, Vacu-Break and Clampmatic are registered trademarks of Siemens Energy & Automation, Inc.

Sentron is a trademark of Siemens Energy & Automation, Inc.

National Electrical Code and NEC are registered trademarks of the National Fire Protection Association, Quincy, MA 02269. Portions of the National Electrical Code are reprinted with permission from NFPA 70-1996, National Electrical Code Copyright, 1995, National Fire Protection Association, Quincy, MA 02269. This reprinted material is not the complete and official position of the National Fire Protection Association on the referenced subject which is represented by the standard in its entirety.

Underwriters Laboratories Inc. is a registered trademark of Underwriters Laboratories Inc., Northbrook, IL 60062. The abbreviation "UL" shall be understood to mean Underwriters Laboratories Inc.

Other trademarks are the property of their respective owners.

# Distribution Systems

A distribution system is a system that distributes electrical power throughout a building. Distribution systems are used in every residential, commercial, and industrial building.

## Residential distribution

Most of us are familiar with the distribution system found in the average home. Power, purchased from a utility company enters the house through a metering device. The power is then distributed from a load center to various branch circuits for lighting, appliances, and electrical outlets.

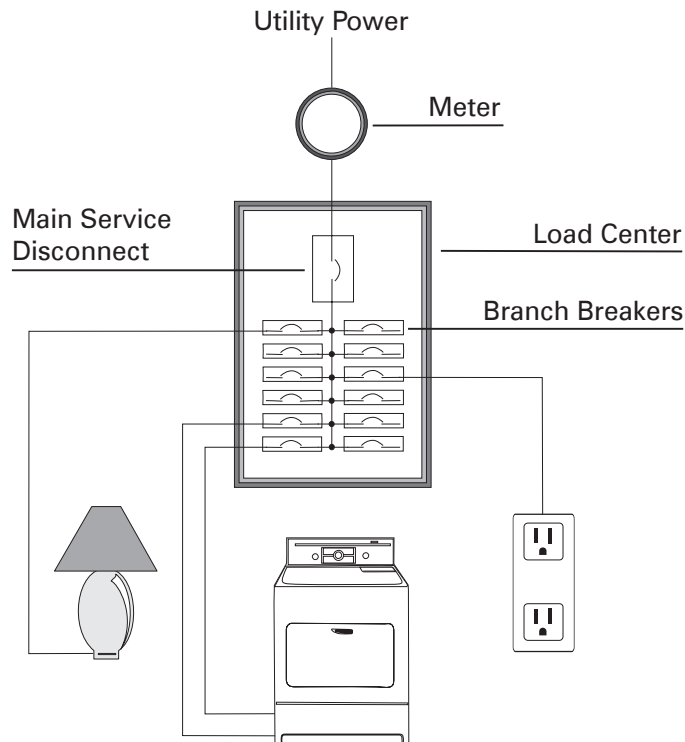

## Industrial distribution

Distribution systems used in multifamily, commercial, and industrial locations are more complex. A distribution system consists of metering devices to measure power consumption, main and branch disconnects, protective devices, switching devices to start and stop power flow, conductors, and transformers. Power may be distributed through various switchboards, transformers, and panelboards. Good distribution systems don't just happen. Careful engineering is required so that the distribution system safely and efficiently supplies adequate electric service to both present and possible future loads.

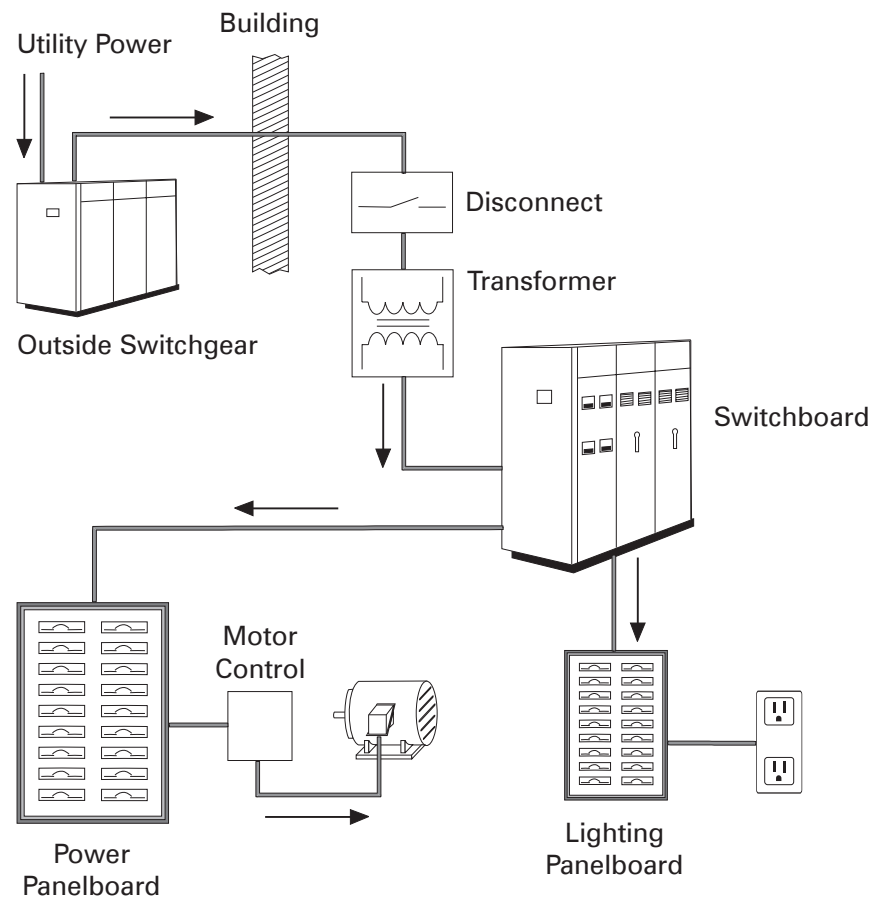

# Panelboards

Electrical distribution systems, whether simple or complex, typically include panelboards, the focus of this course. Panelboards provide circuit control and overcurrent protection.

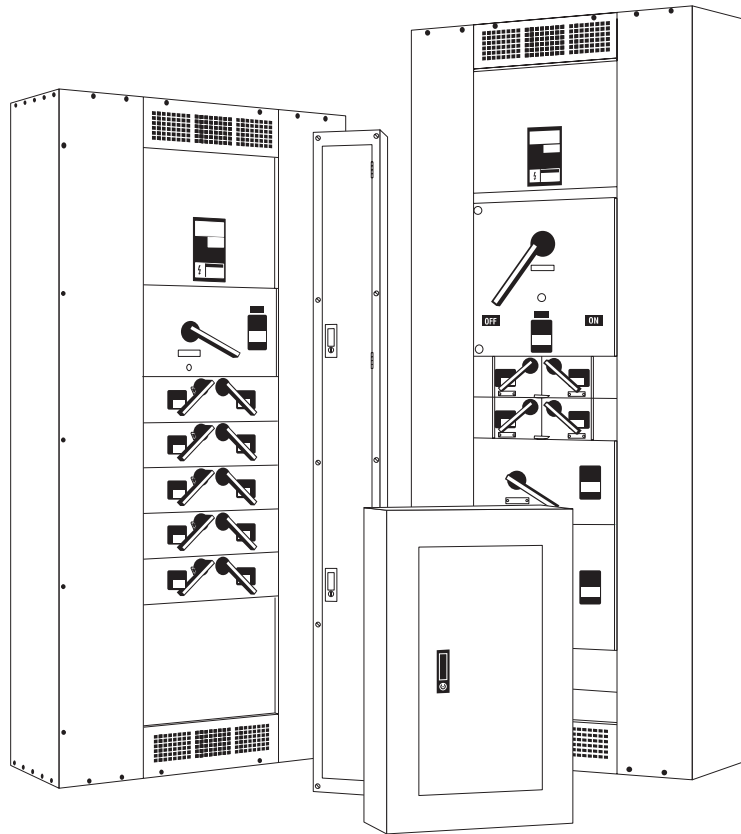

## Panelboard definition

The National Electrical Code® (NEC®) defines a panelboard as *a single panel or group of panel units designed for assembly in the form of a single panel; including buses, automatic overcurrent devices, and equipped with or without switches for the control of light, heat, or power circuits; designed to be placed in a cabinet or cutout box placed in or against a wall or partition and accessible only from the front* (Article 100-definitions).

NEC® and National Electrical Code® are registered trademarks of the National Fire Protection Association.

According to the *NEC* definition, panelboards are:

- Used to control light, heat, or power circuits
- Placed in a cabinet or cutout box
- Mounted in or on a wall
- Accessible only from the front

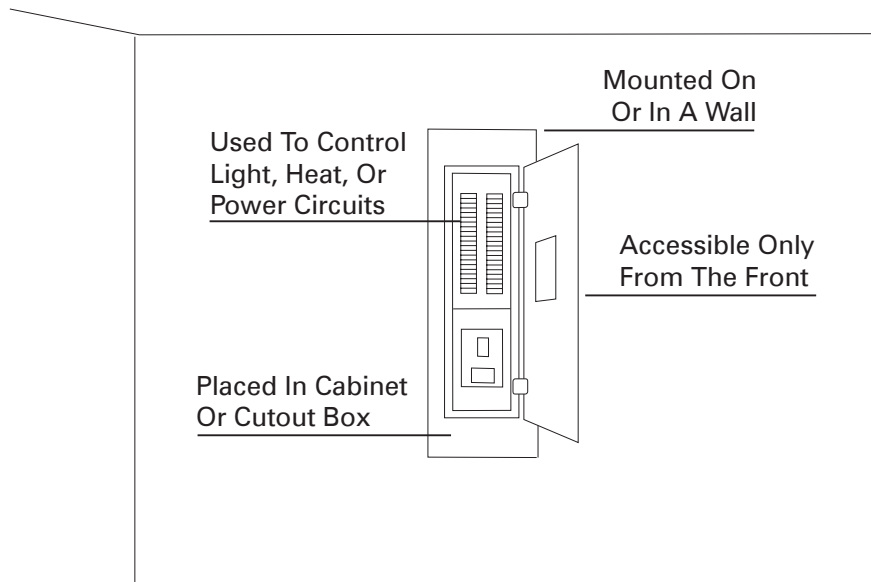

**Note:** Article 384 in the *National Electrical Code* covers panelboards. The basic requirements for panelboards are given in *NEC* Sections 384-13 through 384-16. You are encouraged to become familiar with this material.

Panelboards basically fall into two categories:

- Lighting and appliance
- Power and distribution

## Lighting and appliance panelboards

Article 384-14 and 384-15 of the *National Electrical Code* gives three primary requirements for lighting and appliance panelboards. In order for a panelboard to be a lighting and appliance panelboard, according to *NEC 384-14*, the following conditions must be met:

1. More than 10% of the overcurrent devices (poles) must be rated 30 amps or less.
2. A neutral connection must be provided.

Once a panelboard has met the two previous conditions required of a lighting and appliance panelboard, then a third condition exists in *NEC 384-15*.

3. A maximum of 42 overcurrent devices (poles) are allowed in any one cabinet or enclosure.

## Neutral connection

A neutral is a current-carrying component that is connected to the third wire of a single-phase, three wire system or the fourth wire of a three-phase, four wire system. For example, the following illustration shows the secondary of a 480 volt, wye-connected, three-phase transformer. There is 480 volts between phases and 277 volts between any phase and neutral (N).

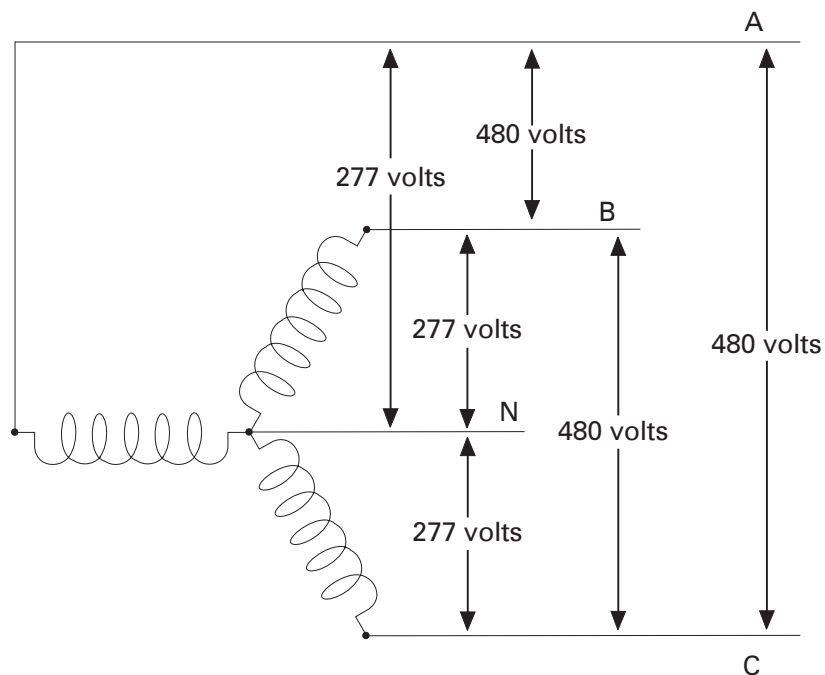

## Overcurrent devices

Each pole of a circuit breaker is considered one overcurrent device. For example, a 1-pole breaker is one overcurrent device and a 2-pole breaker is two overcurrent devices. A maximum of 42 overcurrent devices are allowed in a lighting and appliance panelboard.

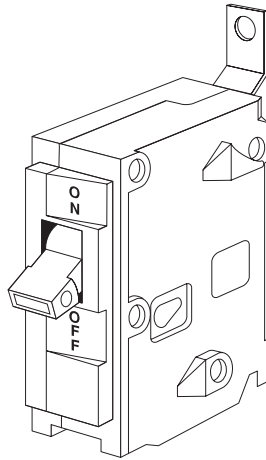

1-Pole Circuit Breaker  
One Overcurrent Device

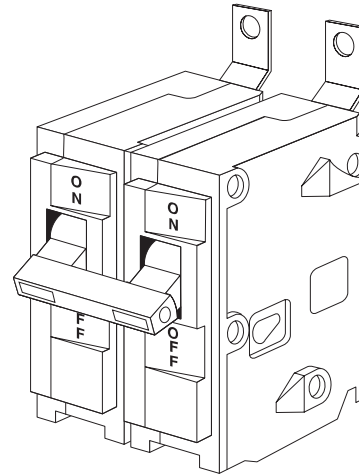

2-Pole Circuit Breaker  
Two Overcurrent Devices

## More than 10% of the overcurrent devices are rated 30 amps or less

In the following example, a three-phase, four-wire (the fourth wire is neutral) distribution system is used to supply a panelboard. The panelboard has five 1-pole, 15 A breakers; twenty-one 1-pole, 20 A breakers; and eight 2-pole, 40 A breakers for a total of 42 overcurrent devices. Ten percent or more of these overcurrent devices must be rated for 30 amps or less. In this example five overcurrent devices are required (10% of 42 = 4.2). There are 26 overcurrent devices rated at 30 amps or less. This is a lighting and appliance panelboard.

Number Of Circuit Breakers	Description	Number Of Overcurrent Devices
5	1-Pole, 15 A	5
21	1-Pole, 20 A	21
8	2-Pole, 40A	<u>16</u>
		42

**Power and distribution panelboards**

*NEC* defines power and distribution panelboards as all panelboards that are not lighting and appliance. In the following example there are only four overcurrent devices which are rated at 30 amps or less. This panelboard does not qualify as a lighting and appliance panelboard. It is a power and distribution panelboard.

Number Of Circuit Breakers	Description	Number Of Overcurrent Devices
4	1-Pole, 30 A	4
22	1-Pole, 40 A	22
8	2-Pole, 40A	<u>16</u>
		42

**Review 1**

1. A \_\_\_\_\_ distributes electrical power throughout a building.
2. Which of the following does not meet the *NEC* definition for a panelboard?
  - a. controls light, heat, or power circuit
  - b. accessible from the front or back
  - c. mounted in or on a wall
  - d. placed in a cabinet or cutout box
3. Article \_\_\_\_\_ in the *National Electrical Code* covers panelboards.
4. The following is an example of a \_\_\_\_\_ and \_\_\_\_\_ panelboard.

Number Of Circuit Breakers	Description	Number Of Overcurrent Devices
2	3-Pole, 60 A	6
4	2-Pole, 30 A	8
4	1-Pole, 15 A	<u>4</u>
		18

Why? \_\_\_\_\_

# Overcurrent Protective Devices

Excessive current is referred to as overcurrent. The *National Electrical Code* defines overcurrent as *any current in excess of the rated current of equipment or the ampacity of a conductor. It may result from overload, short circuit, or ground fault* (Article 100-definitions).

Current flow in a conductor always generates heat. The greater the current flow, the hotter the conductor. Excess heat is damaging to electrical components. For that reason, conductors have a rated continuous current carrying capacity or ampacity. Overcurrent protection devices are used to protect conductors from excessive current flow. These protective devices are designed to keep the flow of current in a circuit at a safe level to prevent the circuit conductors from overheating.

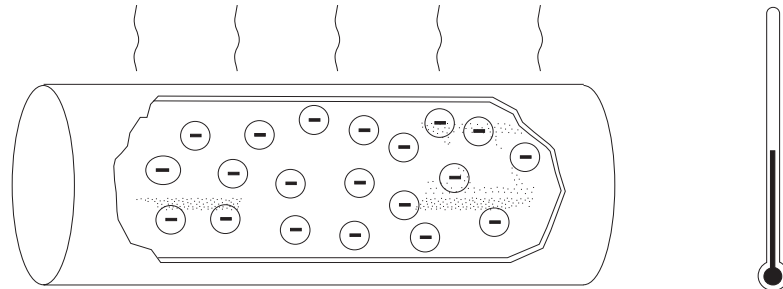

Normal Current Flow

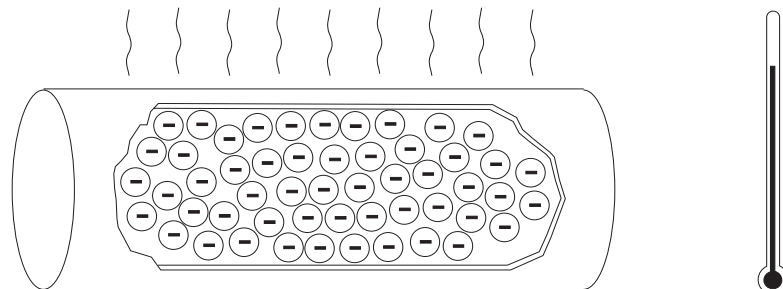

Excessive Current Flow

Circuit protection would be unnecessary if overloads and short circuits could be eliminated. Unfortunately, overloads and short circuits do occur. To protect a circuit against these currents, a protective device must determine when a fault condition develops and automatically disconnect the electrical equipment from the voltage source. An overcurrent protection device must be able to recognize the difference between overcurrents and short circuits and respond in the proper way. Slight overcurrents can be allowed to continue for some period of time, but as the current magnitude increases, the protection device must open faster. Short circuits must be interrupted instantly.

### Fusible disconnect switch

A fusible disconnect switch is one type of device used on panelboards to provide overcurrent protection. Properly sized fuses located in the switch open when an overcurrent condition exists.

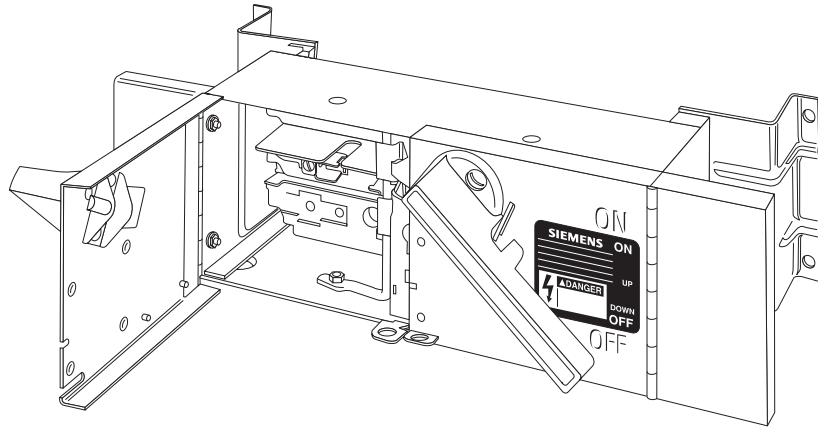

### Fuse

A fuse is a one-shot device. The heat produced by overcurrent causes the current carrying element to melt open, disconnecting the load from the source voltage.

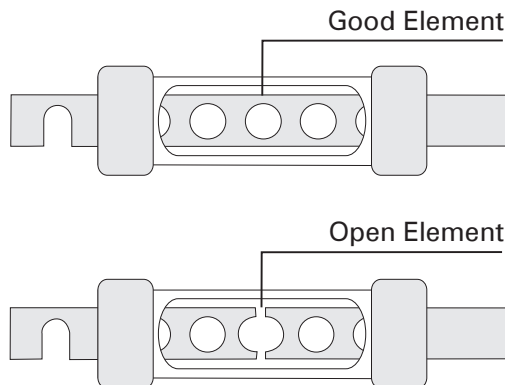

## Nontime-delay fuses

Nontime-delay fuses provide excellent short circuit protection. When an overcurrent occurs, heat builds up rapidly in the fuse. Nontime-delay fuses usually hold 500% of their rating for approximately one-fourth second, after which the current-carrying element melts. This means that these fuses cannot be used in motor circuits which often have inrush currents greater than 500%.

## Time-delay fuses

Time-delay fuses provide overload and short circuit protection. Time-delay fuses usually allow five times the rated current for up to ten seconds to allow motors to start.

## Fuse classes

Fuses are grouped into classes based on their operating and construction characteristics. Each class has an ampere interrupting capacity (AIC) which is the amount of fault current they are capable of interrupting without destroying the fuse casing. Fuses are also rated according to the maximum continuous current and maximum voltage they can handle. Underwriters Laboratories (UL) establishes and standardizes basic performance and physical specifications to develop its safety test procedures. These standards have resulted in distinct classes of low voltage fuses rated at 600 volts or less. The following chart lists the fuse class and its AIC rating.

Class	AIC Rating
H	10,000 A
K	50,000 A
R	200,000 A
J	200,000 A
L	200,000 A

## Class R fuseholder

An optional Class R fuseholder can be used to prevent any other type of fuse from being used. The Class R rejection clip contains a pin that permits only the notched Class R fuse to be inserted. This prevents a lower rated fuse from being used.

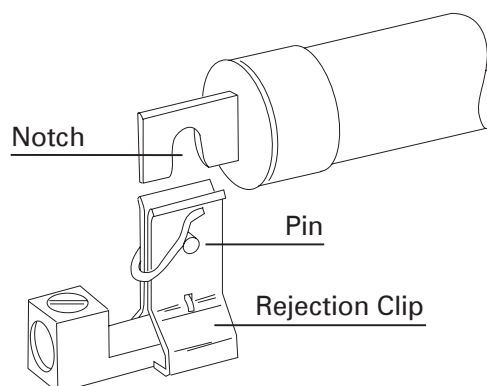

## Circuit breakers

Another device used for overcurrent protection is a circuit breaker. The *National Electrical Code* defines a circuit breaker as *a device designed to open and close a circuit by nonautomatic means, and to open the circuit automatically on a predetermined overcurrent without damage to itself when properly applied within its rating.*

Circuit breakers provide a manual means of energizing and deenergizing a circuit. In addition, circuit breakers provide automatic overcurrent protection of a circuit. A circuit breaker allows a circuit to be reactivated quickly after a short circuit or overload is cleared. Unlike fuses which must be replaced when they open, a simple flip of the breaker's handle restores the circuit.

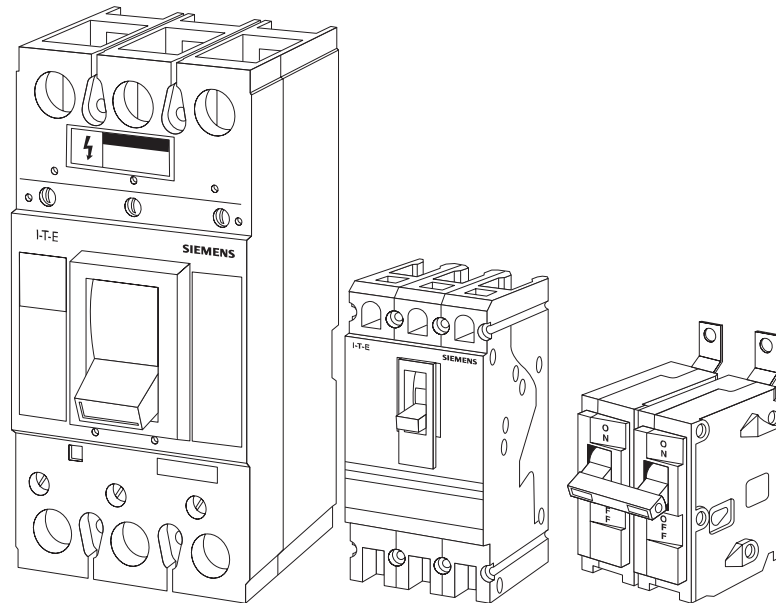

## Ampere rating

Like fuses, every circuit breaker has a specific ampere, voltage, and fault current interruption rating. The ampere rating is the maximum continuous current a circuit breaker can carry without exceeding its rating. As a general rule, the circuit breaker ampere rating should match the conductor ampere rating. For example, if the conductor is rated for 20 amps, the circuit breaker should be rated for 20 amps. Siemens I-T-E® breakers are rated on the basis of using 60° C or 75° C conductors. This means that even if a conductor with a higher temperature rating were used, the ampacity of the conductor must be figured on its 60° C or 75° C rating.

There are some specific circumstances when the ampere rating is permitted to be greater than the current carrying capacity of the circuit. For example, motor and welder circuits can exceed conductor ampacity to allow for inrush currents and duty cycles within limits established by *NEC*.

Generally the ampere rating of a circuit breaker is selected at 125% of the continuous load current. This usually corresponds to the conductor ampacity which is also selected at 125% of continuous load current. For example, a 125 amp circuit breaker would be selected for a load of 100 amps.

### **Voltage rating**

The voltage rating of the circuit breaker must be at least equal to the circuit voltage. The voltage rating of a circuit breaker can be higher than the circuit voltage, but never lower. For example, a 480 VAC circuit breaker could be used on a 240 VAC circuit. A 240 VAC circuit breaker could not be used on a 480 VAC circuit. The voltage rating is a function of the circuit breakers ability to suppress the internal arc that occurs when the circuit breaker's contacts open.

### **Fault current interruption rating**

Circuit breakers are also rated according to the level of fault current they can interrupt. When applying a circuit breaker, one must be selected which can sustain the largest potential short circuit current which can occur in the selected application. Siemens circuit breakers have interrupting ratings from 10,000 to 200,000 amps. To find the interrupting rating of a specific circuit breaker refer to the Speedfax catalog.

# Panelboard Construction

There are several components that make up a panelboard. Panelboards contain a can, interior, circuit protection devices, label, and trim.

## The can

The can is typically constructed of galvanized steel and houses the other components. The can is also referred to as the box or an enclosure. It is designed to provide component and personnel protection. Removable blank end panels allow the user to cut whatever conduit holes are necessary. Prestamped knockouts are available as an option. Mounting studs are used to support the interior or group mounted devices.

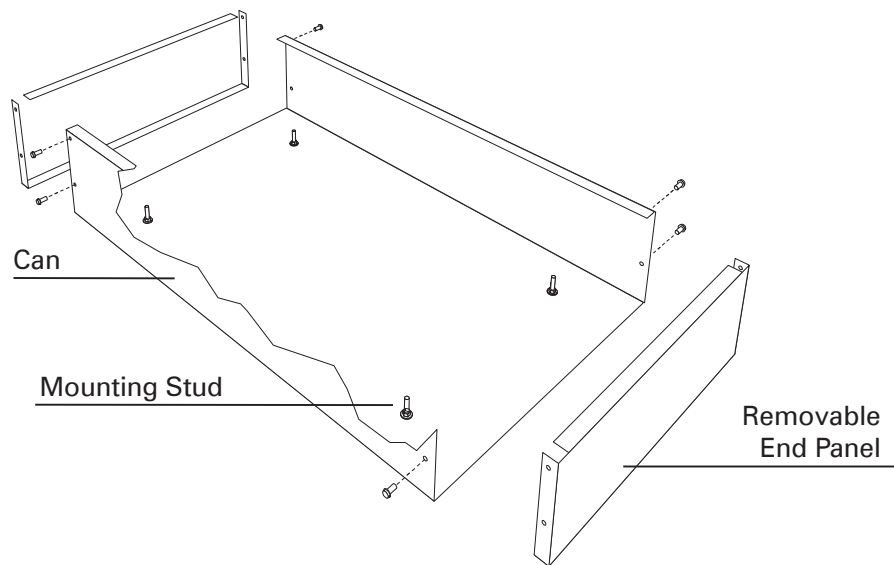

## Cans Ahead

Siemens has a “Cans Ahead” program in which the can of some panelboards can be shipped separately of the interior and trim. This allows the contractor to install the can first before the wall is finished. For information on this program contact your Siemens sales representative.

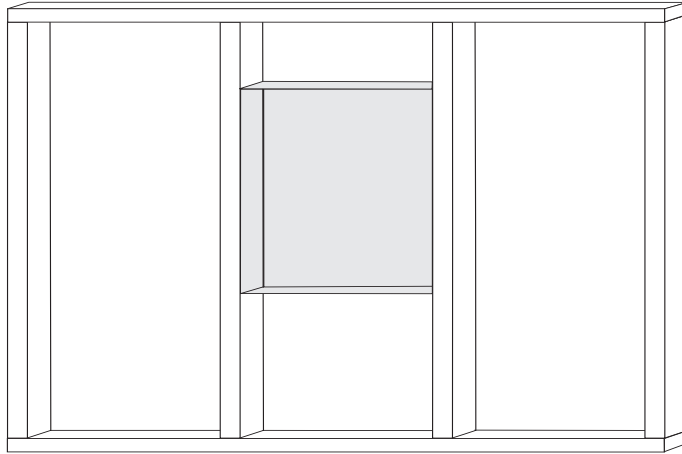

## Interior

The interior consists of several components, including overcurrent protection devices, bus bars and insulated neutral bus bars. The interior is mounted to the four mounting studs in the can. Jacking screws (not shown) allow adjustment of the interior within the enclosure.

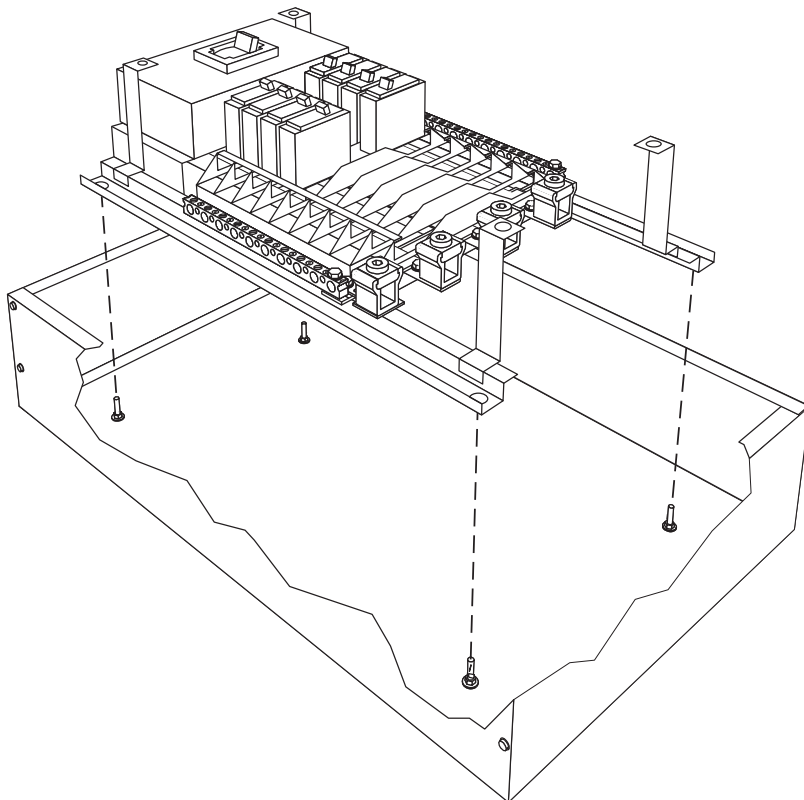

## Bus bars

A bus bar is a conductor that serves as a common connection for two or more circuits. It is represented schematically by a straight line with a number of connections made to it. *NEC* article 384-3 states that bus bars *shall be located to be free from physical damage and shall be held firmly in place*. Standard bus bars on Siemens panelboards are made of aluminum, but copper bus bars are available as an option.

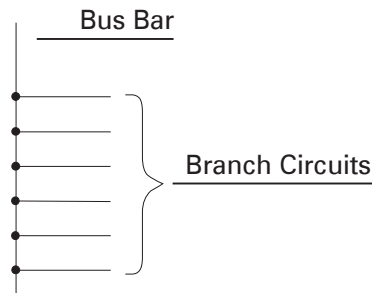

Bus bars are required to have phases in sequence so that an installer can have the same fixed phase arrangement in each termination point in any panelboard or switchboard. This is established by NEMA (National Electrical Manufacturers Association). It is possible to have a non-NEMA phase sequence which would have to be marked on the panelboard. It is assumed that bus bars are arranged according to NEMA. The following diagram illustrates accepted NEMA phase arrangements.

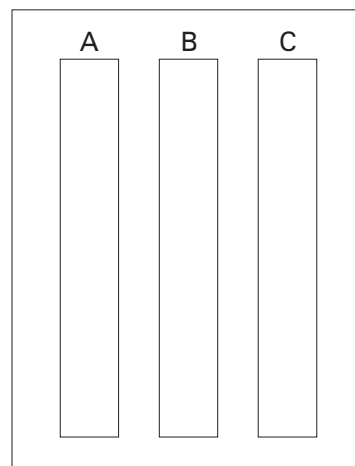

Vertical

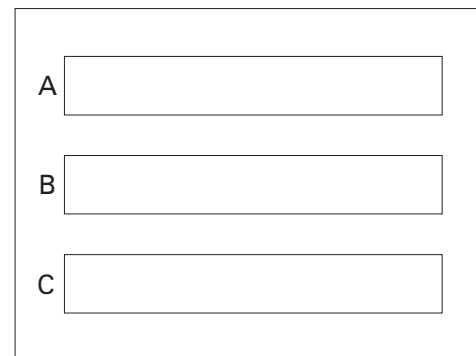

Horizontal

## Split neutral

An insulated neutral bus is provided. In many instances it is a split neutral, meaning that an equal number of neutral connections are available on both sides of the panelboard. Split neutrals are connected together through a bus bar. An insulation separates the neutral bus from the power supply bus bars.

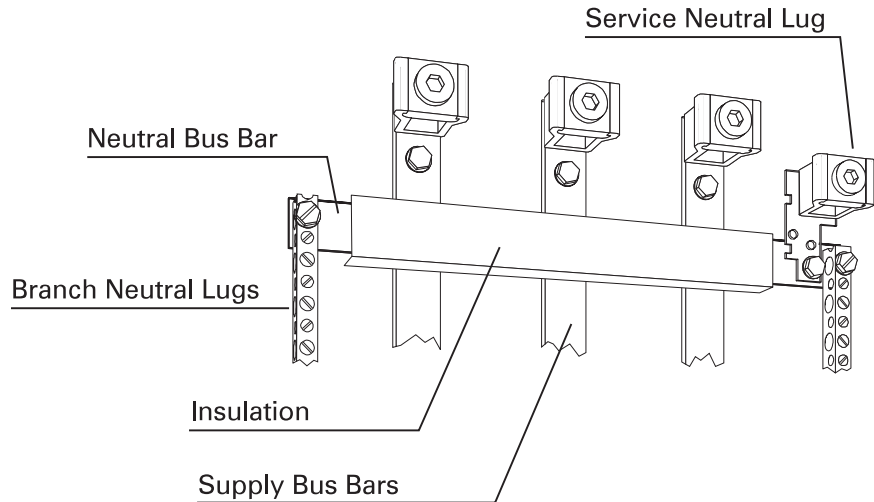

## 200% neutral

Some loads can cause harmonics and non-linear loading on a distribution system. This requires special consideration when ordering a panelboard. One way to deal with non-linear loads is to double the capacity of the panelboard neutral. A 200% neutral can be factory installed or, in the case of the S1, S2 and SE, field installed.

## Circuit protection devices

Circuit protection devices mount directly to the bus bars. In the following illustration for example, a BL circuit breaker is mounted to the panelboard bus.

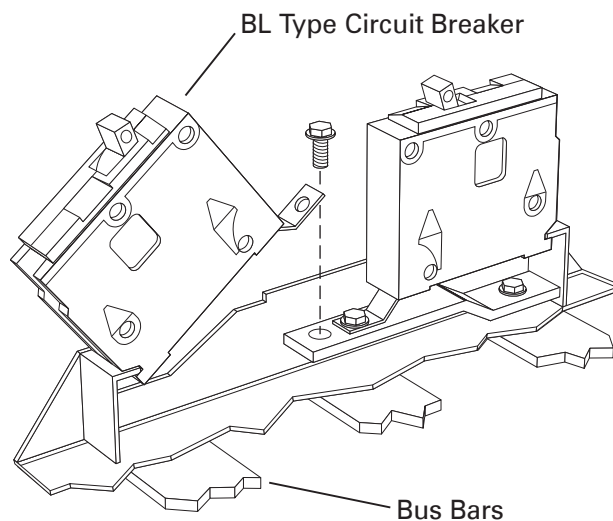

## Circuit identification

Circuits must be clearly labeled. Poles arranged with odd numbers on the panelboard's right (your left) and even numbers on the panelboard's left (your right) is referred to as NEMA numbering. In some areas a vertical sequence is required. In addition a directory card is placed in a holder which is attached to the inside of the door.

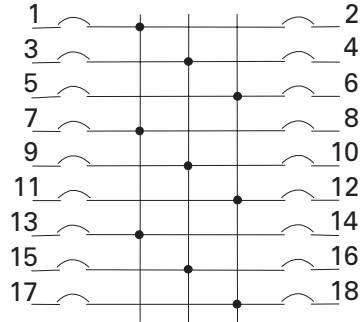

NEMA Numbering

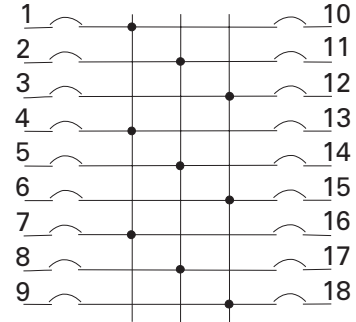

Vertical Numbering

## Label

The label identifies the panelboard's type, voltage rating, and ampacity.

## SIEMENS

Panel type	Systems	Provisions are for the following breakers
S1	208Y/120 3Ø4W	BL BLH HBL BLF BLHF BQD
S2	480Y/277 3Ø4W 480Y/277 3Ø3W	BQD

SEE LABEL BELOW FOR PANEL TYPE  
250 Amps max. ( see main device or breaker)

Use Siemens QF-3 filler plates to cover all unused circuits.

Field conductors can be 60° c or 75° c cu, or al.

Breaker handle in the intermediate position indicates tripped. To reset, move the handle to the extreme off position, then on.

Short circuit information is located on the rear of this cover.

Suitable for service equipment with a main overcurrent device or when not more than six service disconnects are provided and when not used as a lighting and appliance branch circuit panelboard; see Article 384-14 of the National Electrical Code.

**Caution:** if more than 10% of the breaker poles are supplying lighting and appliance circuits, then this unit is not to exceed 42 circuits **NEC Article 384-14 and 15**

These panels are to be mounted in the following minimum size enclosures:  
20 w. x 5.75 dp. x 32 h. for 18 circuit  
38 h. for 30 circuit  
44 h. for 42 circuit

**⚠ DANGER**  
High voltage  
Will cause severe injury or death, keep out.  
Qualified Personnel only  
Lock off power supplying this equipment before working inside.

Field installable kits for the addition of mains and customizing this Panel to meet special requirements are listed on the rear of the dead front.

For emergency service call  
1-800-241-4453

Siemens Energy & Automation, Inc. Atlanta, Ga. USA

## Dead front and trim

The dead front and trim are the front surfaces of the panelboard that cover the interior. The trim includes an access door. These components provide access to the overcurrent devices while sealing off the bus bars and internal wiring from contact.

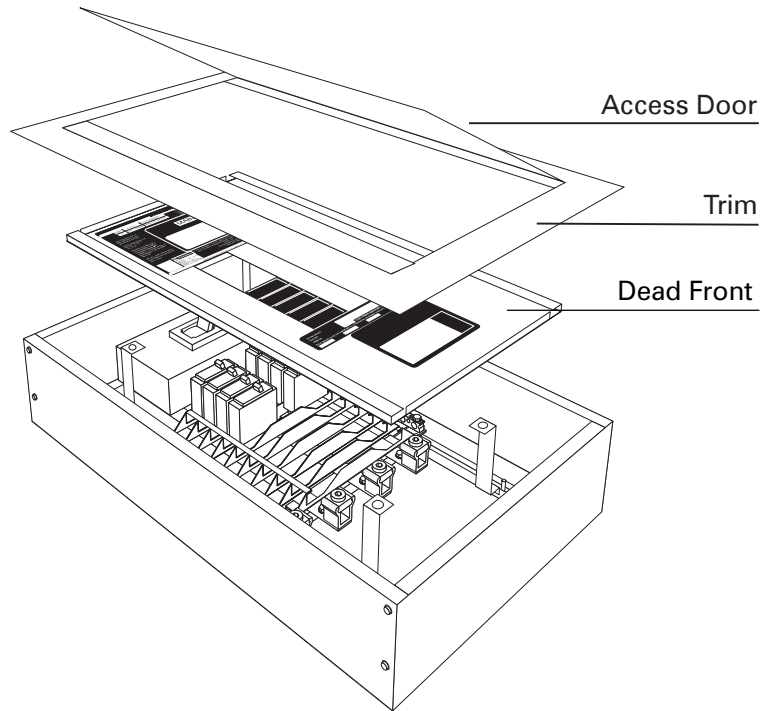

## QF3 filler plates

Part of the dead front are the QF3 filler plates. These are used to cover any unused pole spaces not filled by a circuit breaker.

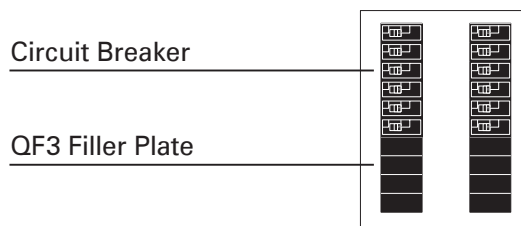

## Enclosures

The National Electrical Manufacturers Association (NEMA) has established guidelines for electrical equipment enclosures. Siemens panelboards are supplied as standard in a NEMA Type 1 enclosure which is intended for general purpose indoor use.

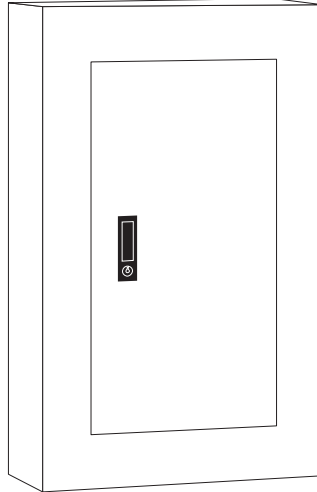

The following enclosures are available as an option:

- Type 3R Enclosures are intended for outdoor use primarily to provide a degree of protection against rain, sleet and damage from external ice formation.
- Type 4X Enclosures are intended for indoor or outdoor use primarily to provide a degree of protection against corrosion, windblown dust and rain, splashing water, hose-directed water, and damage from external ice formation.
- Type 3R/12 Enclosures are intended for indoor use primarily to provide a degree of protection against circulating dust, falling dirt, and dripping noncorrosive liquids.

## Panelboard installation

Additional information concerning NEMA enclosures can be found in NEMA publication 250-1991, Enclosures for Electrical Equipment (1000 Volts Maximum). Article 110-16 of the *National Electrical Code* specifies clearances around panelboards which will provide sufficient access and working space. You should become familiar with this material. There are three basic rules which we must be concerned with:

- Minimum distance from the panelboard to ground shall be 3 feet for 0-150 volt systems and 4 feet for 151-600 volt systems.
- Space in front of the equipment shall be at least 30 inches wide and be sufficient to allow the hinged door to open 90 degrees.
- There shall be a minimum of 6 ½ feet of headroom.

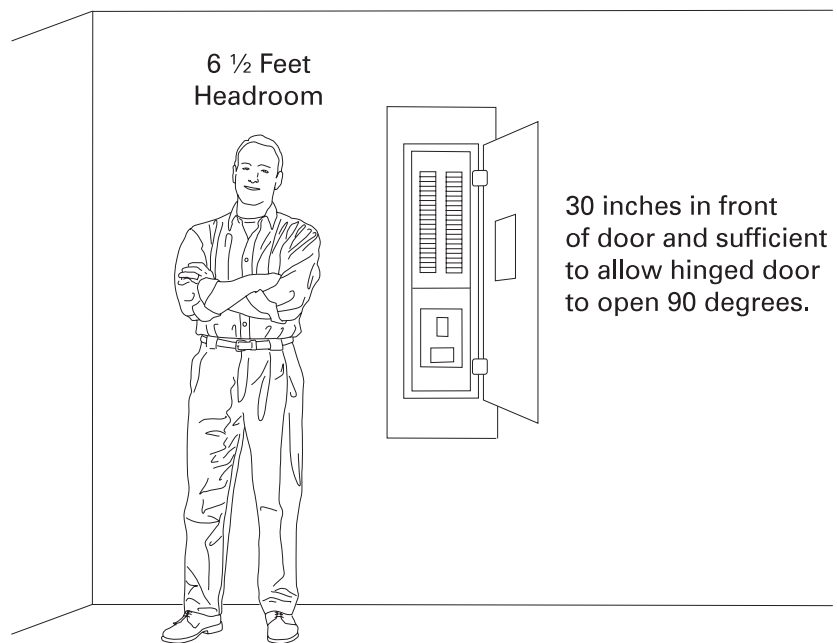

## Review 2

1. A \_\_\_\_\_ is a conductor that serves as a common connection for two or more circuits.
2. Circuit protection devices are designed to keep the flow of \_\_\_\_\_ in a circuit at a safe level to prevent the circuit conductors from overheating.
3. Three causes of overcurrent are:
  - a. \_\_\_\_\_
  - b. \_\_\_\_\_
  - c. \_\_\_\_\_
4. A Class K fuse has an ampere interrupting capacity of \_\_\_\_\_ amps.
5. A Class \_\_\_\_\_ fuse has a notch to fit a rejection clip.
6. Circuit breakers are rated for continuous \_\_\_\_\_, \_\_\_\_\_, and fault current interruption capacity.
7. The panelboard components designed to seal off the bus bars and internal wiring from contact are the \_\_\_\_\_ and \_\_\_\_\_.
8. Siemens panelboards are supplied standard in a NEMA Type \_\_\_\_\_ enclosure.

# Types Of Panelboards

There are two types of panelboards, main breaker and main lug only.

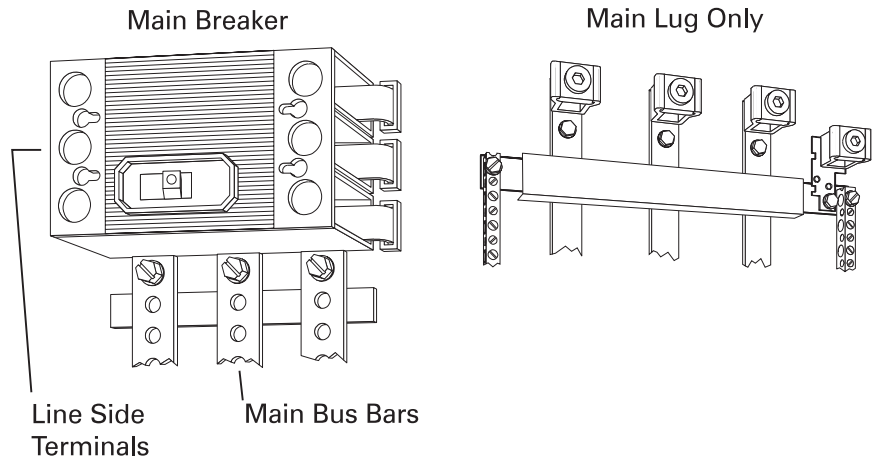

## Main breaker type panelboard

The incoming supply cables of a main breaker type panelboard are connected to the line side of the main breaker, which in turn feeds power to the panelboard and its branch circuits. The main breaker disconnects power from the panelboard and protects the system from short circuits, overloads and ground faults if equipped with ground fault protection. Siemens main breakers are bus connected to the main bus bars. This means there are no cable connections required from the main circuit breaker to the lugs on the main bus bars. Bus connecting provides a higher degree of circuit integrity because there is less chance for loose connections which lead to overheating.

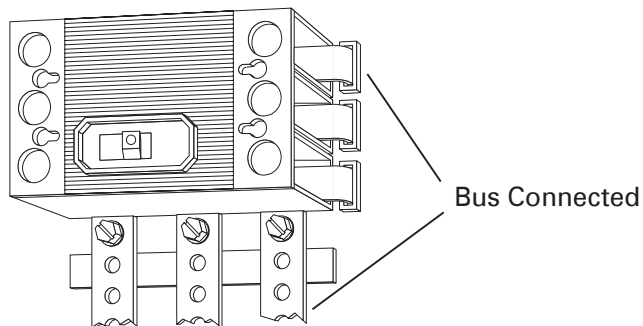

Depending on the panelboard the main breaker can either be mounted horizontally or vertically.

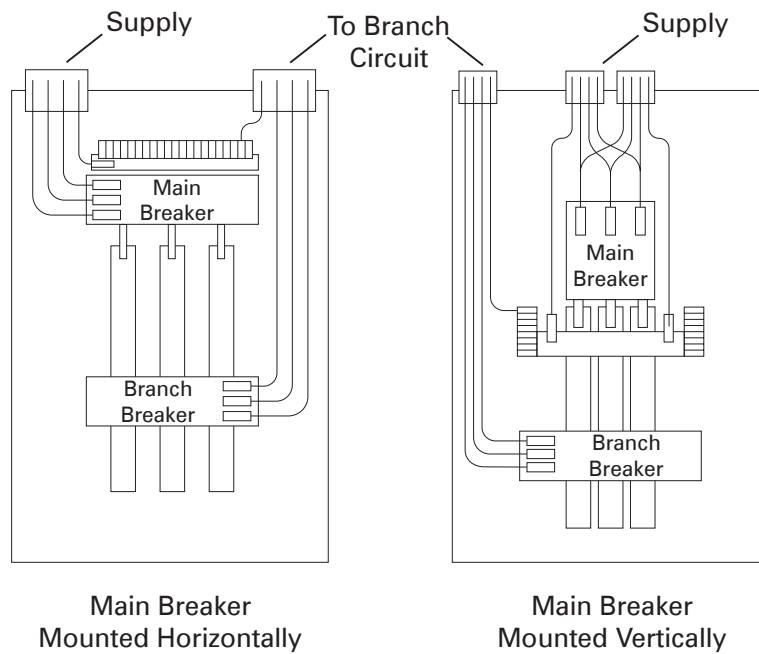

### Main lug only

A main lug only type panelboard does not have a main circuit breaker. The incoming supply cables are connected directly to the bus bars. Primary overload protection for the panelboard is not provided as an integral part of the panelboard.

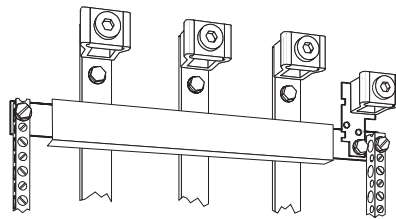

## Feed-through lugs

There are a variety of ways a main breaker or main lug only panelboard might be used. For example, a lighting and appliance panelboard can have a maximum of 42 poles. If more branch circuits were required an additional panelboard could be used. Feed-through lugs are used to connect a main breaker and main lug only panelboard when they are mounted adjacent to each other. A main breaker panelboard uses feed-through lugs mounted on the main bus of the panelboard and interconnecting cables are routed to the main lug only panelboard. The main breaker protects both panelboards from overcurrent.

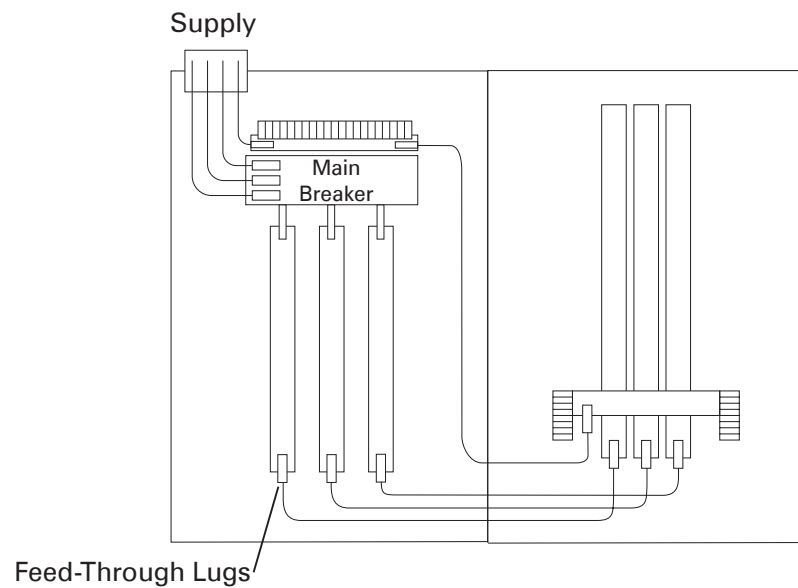

## Sub-feed lugs

Sub-feed lugs are used to connect two main lug only panelboards that are mounted adjacent to each other. For example two main lug only panelboards might be supplied by a circuit breaker or fused disconnect. Power supplied by the overcurrent protection device are routed to the first panelboard. The power is routed to the second panelboard through sub-feed lugs.

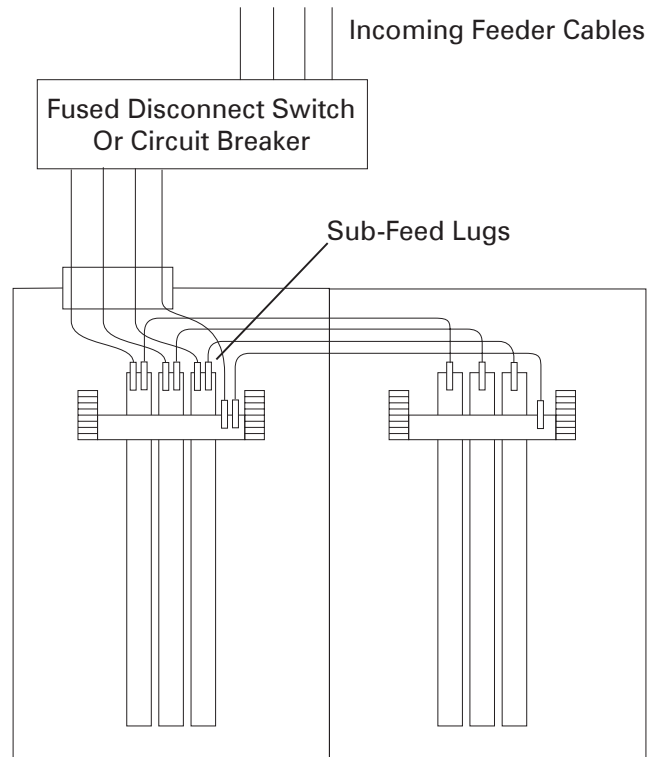

## Unit space and subfeed breakers

Unit space is the area that accommodates the branch circuit breakers in most power panelboards. In addition, the number of branch circuits determines the panel dimensions in lighting panels.

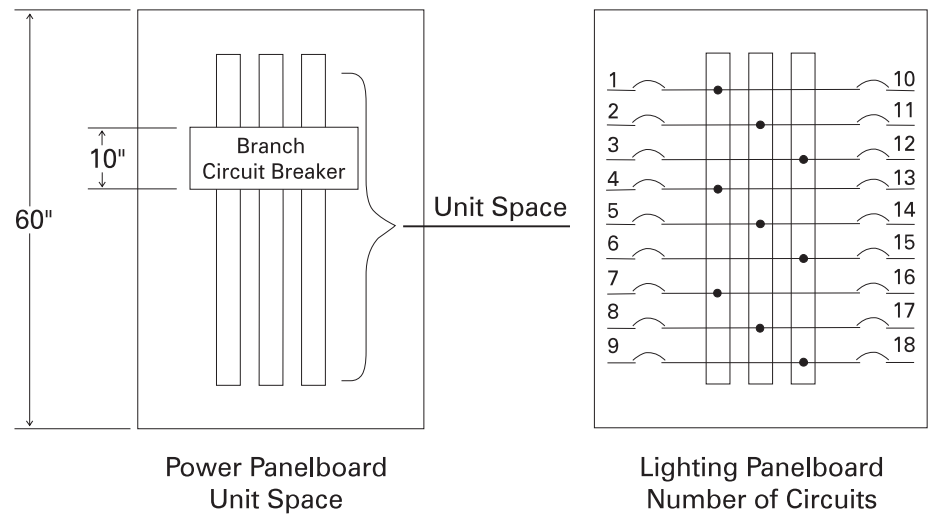

When an application requires a circuit breaker that is a larger frame size than the branch circuit breakers available and will not fit in the branch circuits location, a subfeed breaker can be used. One possible application is to supply a second panelboard located some distance from the first panelboard. This is, however, not the only application. A subfeed breaker can supply any load that a branch circuit breaker can supply.

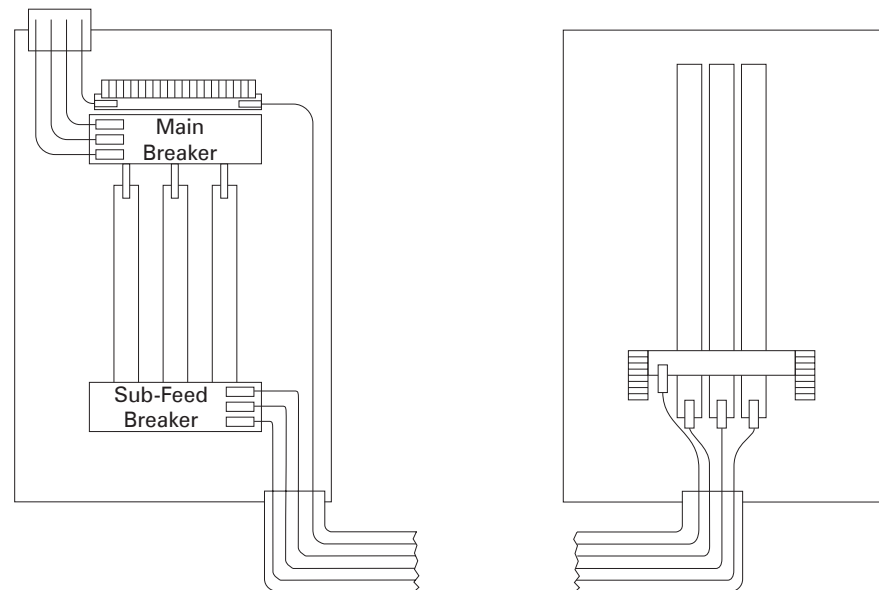

# Individual Overcurrent Protection

The *National Electrical Code* requires panelboards to be individually protected against overcurrent. Main overcurrent protection may be an integral part of a panelboard or located remote from the panelboard. *NEC Article 384-16* states that *each lighting and appliance branch-circuit panelboard shall be individually protected on the supply side by not more than two main circuit breakers or two sets of fuses having a combined rating not greater than that of the panelboard.*

## Individual protection

The following illustration shows two possible ways individual panelboard overcurrent can be accomplished. A main circuit breaker can be located as an integral part of the panelboard or can be located remotely. In this example the main breaker and panelboard are both rated for 600 amps.

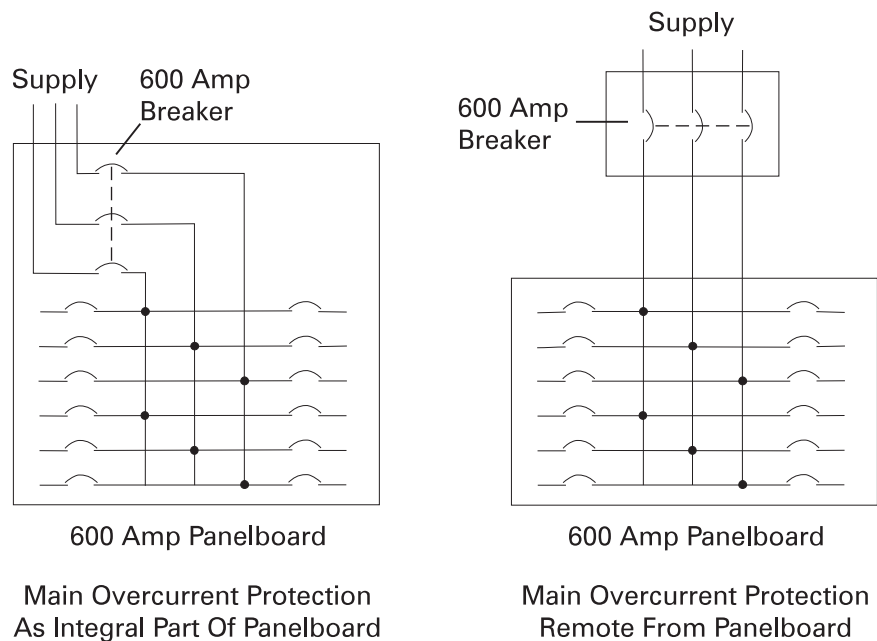

## Split bus

Panelboards can have as many as two main circuit breakers or two sets of fuses to protect. When two main circuit breakers are used in a panelboard a split bus is used. Half of the branch circuits are protected by one main circuit breaker and half protected by the other main circuit breaker.

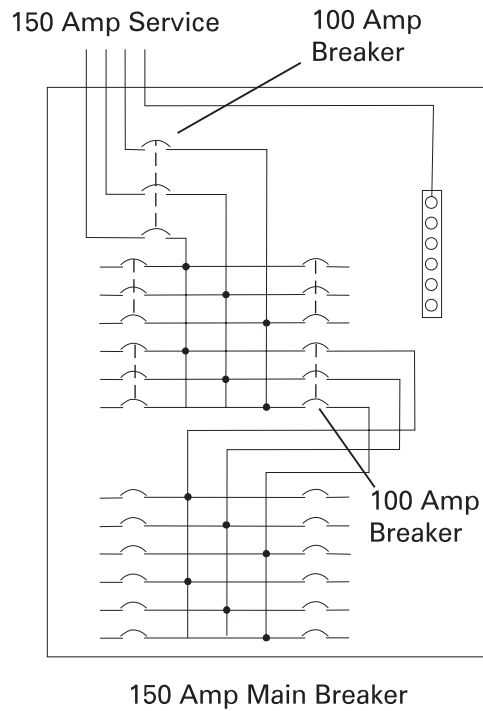

**Exception to NEC 384-16**

There is an exception to NEC Article 384-16. *Exception No. 1: Individual protection for a lighting and appliance panelboard shall not be required if the panelboard feeder has overcurrent protection not greater than the rating of the panelboard.* The following illustration shows two panelboards protected by a single 600 Amp fused disconnect switch. Note that the fused disconnect feeder provides overcurrent protection not greater than the rating of the panelboards.

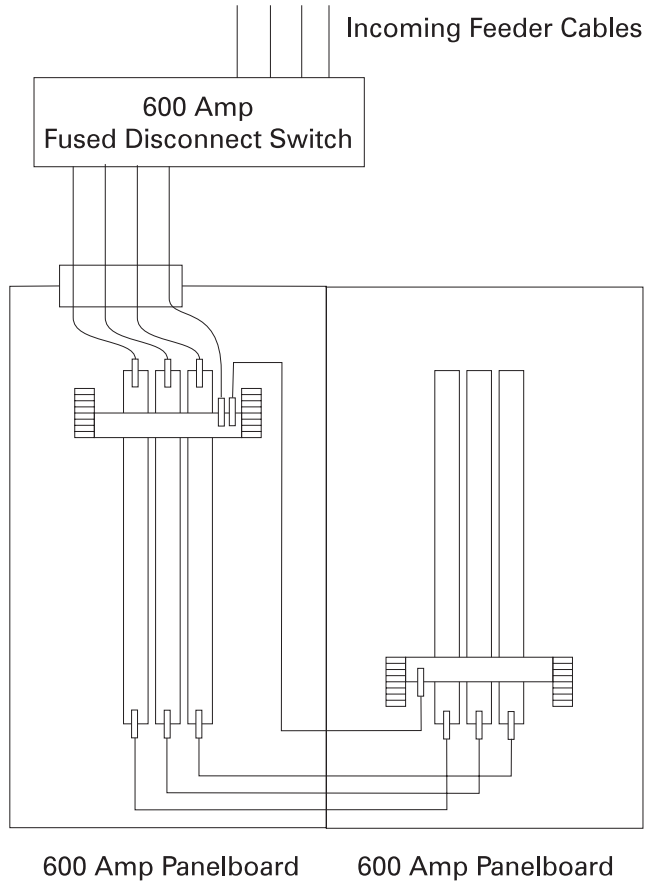

**Panelboards supplied by a transformer**

Frequently a panelboard is supplied by the secondary of a transformer. According to *NEC* Article 384-16d, individual protection for the panelboard must be provided on the secondary side of the transformer. The overcurrent protection device can be installed either ahead of or in the panelboard.

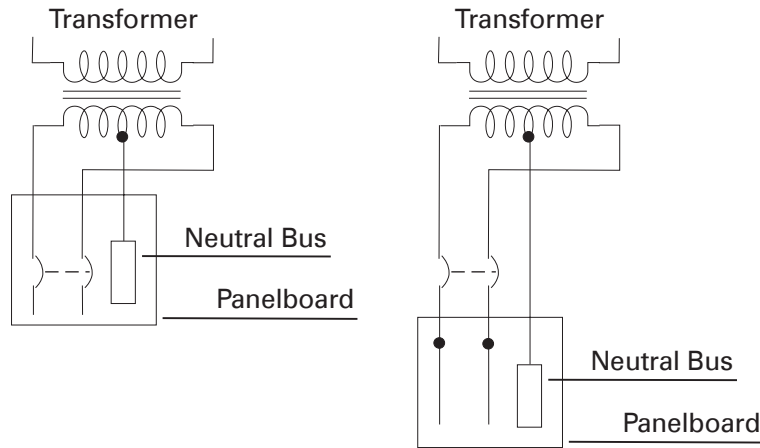

Overcurrent Protection Provided In Panelboard

Overcurrent Protection Provided Ahead Of Panelboard

*NEC* makes an exception to this rule. A panelboard supplied by a single-phase transformer having a 2-wire (single-voltage) secondary can be protected by an overcurrent protection device located on the primary side of the transformer.

### Review 3

1. The two types of panelboards are main \_\_\_\_\_ and main \_\_\_\_\_ only.
2. The main breaker of a main breaker panel can be mounted \_\_\_\_\_ or \_\_\_\_\_ .
3. Primary overload protection for a main \_\_\_\_\_ type panelboard is not provided as an integral part of the panelboard.
4. \_\_\_\_\_ - \_\_\_\_\_ lugs are used to connect a main breaker and main lug only panelboard when they are mounted adjacent to each other.
5. The *NEC* article that covers individual overcurrent protection for panelboards is \_\_\_\_\_ .
6. A lighting and appliance panelboard can have as many as \_\_\_\_\_ main circuit breakers or sets of fuses to protect it.

# Power Supply Systems

Panelboards receive power from a variety of sources. Downstream panelboards may receive power from upstream panelboards or switchboards, however, power for the distribution system originates from a utility power company. Power from the power company is stepped down through transformers to be distributed in residential, commercial and industrial locations. Several systems are used. The following are some examples of systems in use that are suitable for Siemens panelboards.

## Single-phase, three-wire system

The following diagram illustrates one of the most common single-phase, three-wire distribution systems in use today. There are 120 volts between any phase and neutral and 240 volts between phases.

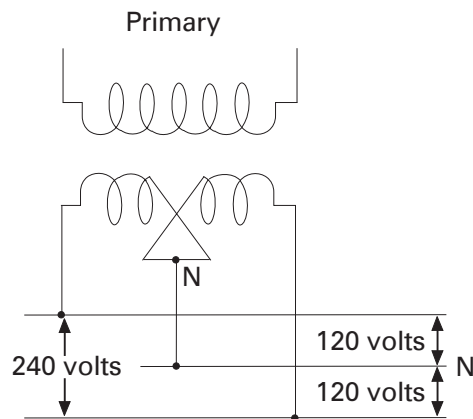

**Three-phase, four-wire,  
 wye-connected  
 transformers**

The following illustration shows the secondary of a 480 Y/277 V three-phase, four-wire, wye-connected transformer. The "480 Y" indicates the transformer is wye-connected and has 480 volts between any two phases. The "277 V" indicates there are 277 volts between any phase and neutral (N). Phase-to-phase voltage is 1.732 times phase-to-neutral voltage ( $277 \times 1.732 = 480$ ).

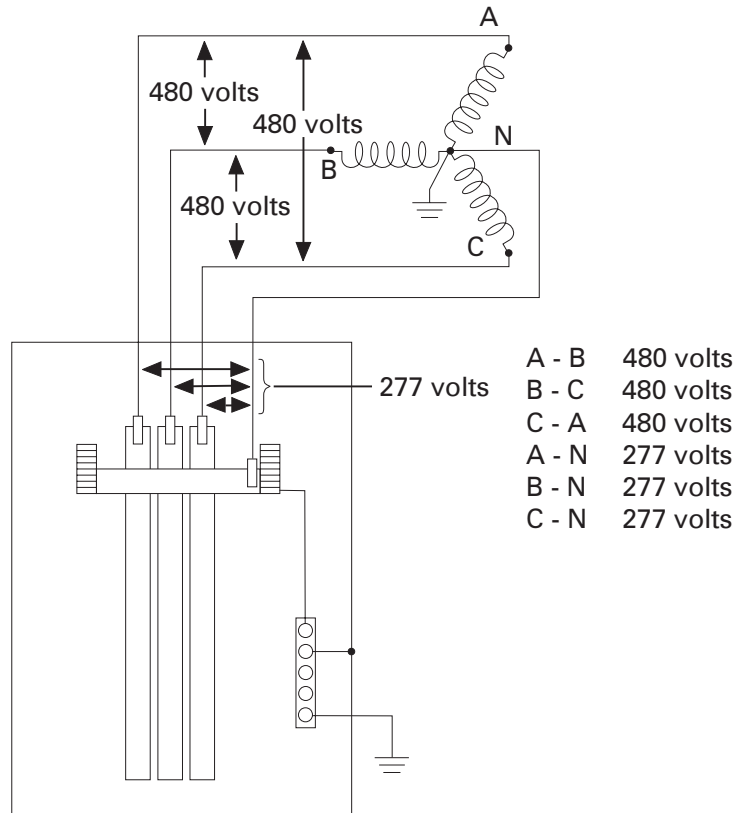

**Three-phase, four-wire,  
delta-connected  
transformers**

A three-phase, four-wire, delta-connected secondary works a little differently. The following illustration shows a delta-connected secondary with 240 volts phase-to-phase. The midpoint of one phase winding is grounded to provide 120 volts between phase A and neutral and 120 volts between phase C and neutral. Between phase B and neutral, however, the voltage is 208 volts. This is referred to as the high leg. The high leg can be calculated by multiplying the phase A to neutral voltage times 1.732 ( $120 \times 1.732 = 208$ ). Single-pole breakers should not be connected to the high leg. *NEC* Article 215-8 requires that the high leg bus bar or conductor be permanently marked with a finish that is orange in color. This will help prevent electricians from connecting 120 volt single-phase loads to the 208 volt high leg. Four-wire, delta-connected transformers should always be wired so that the B phase is the high leg. Not all panelboards are suitable for use on a high leg system. Siemens SE, S4, S5, F1 and F2 panelboards are available for use on a high leg system. Your Siemens sales representative should be contacted for further information.

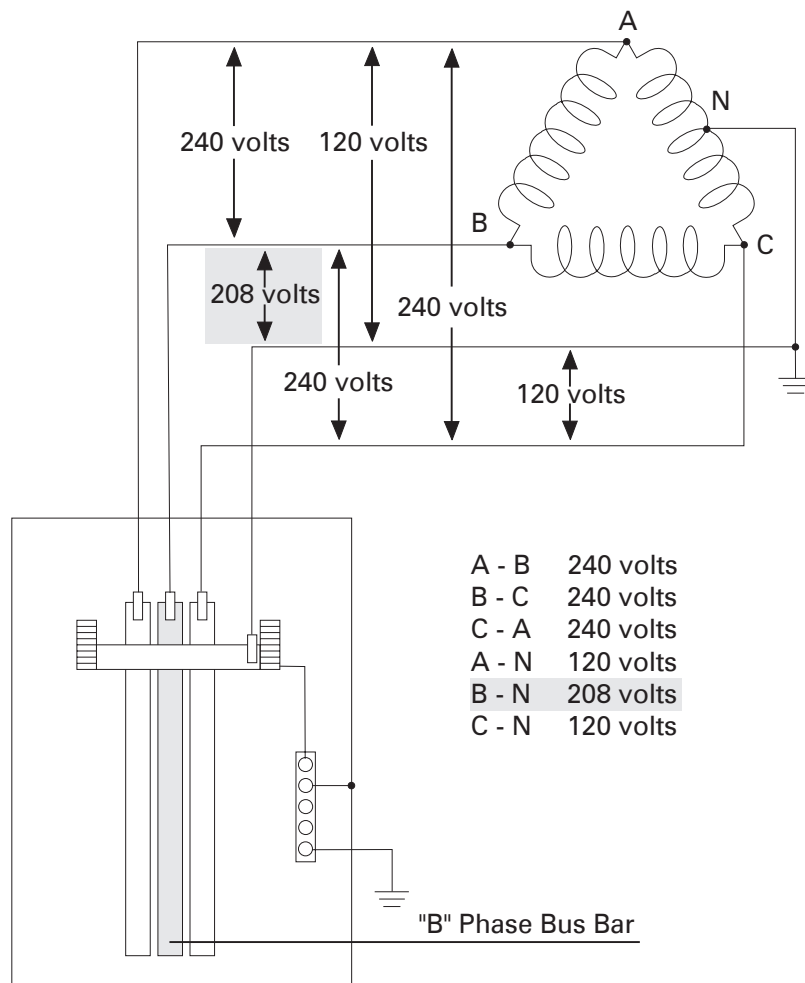

# Service Entrance Panelboards

Sometimes panelboards are used as service entrance equipment for a building. This is the equipment located near where the power supply enters the building. The incoming power supply is connected to this equipment which provides a means to control and cut off the supply. The *National Electrical Code* discusses service entrance equipment in Article 230. Panelboards used as service entrance equipment must be approved and labeled as such. All Siemens Sentron™ Series panelboards are factory labeled as suitable for service entrance equipment when *NEC* requirements are met.

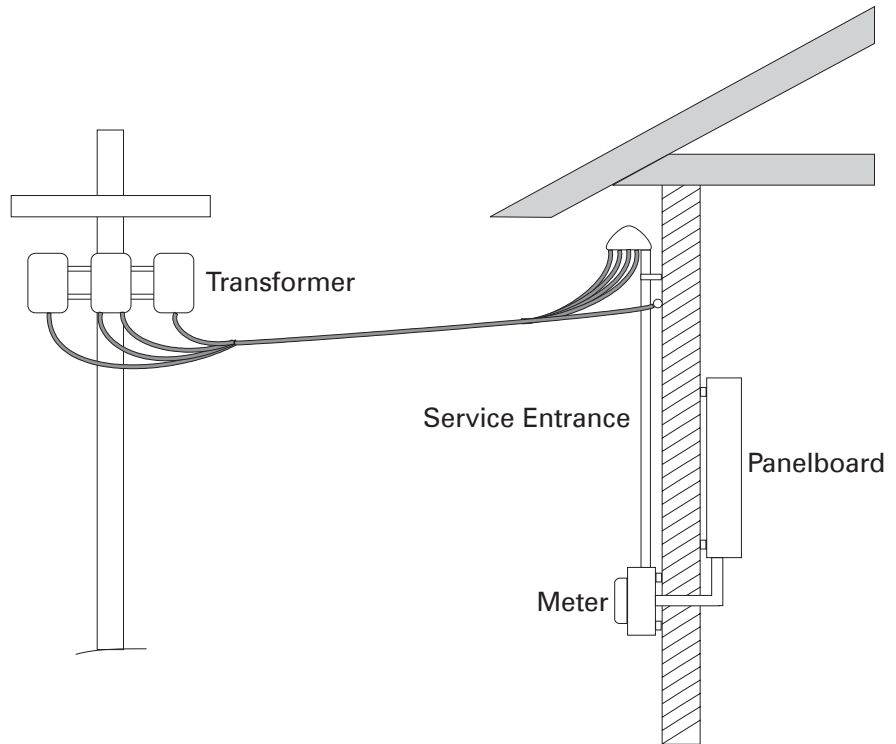

**Maximum number of disconnects for service entrance equipment**

Service-entrance conductors must have a readily accessible means of being disconnected from the power supply. *NEC* Article 230-71a specifies that for each set of service entrance conductors no more than six switches or circuit breakers shall be used to disconnect and isolate the service from all other equipment. There are two ways panelboards can be configured to meet this requirement. In one example, a main breaker panelboard is used. A single main circuit breaker will disconnect power to all equipment being supplied by the service. In another example, a main lug only panelboard is equipped with up to six circuit breakers to disconnect power to all equipment being supplied by the service. In any case, the circuit breaker must be clearly labeled for the load it supplies.

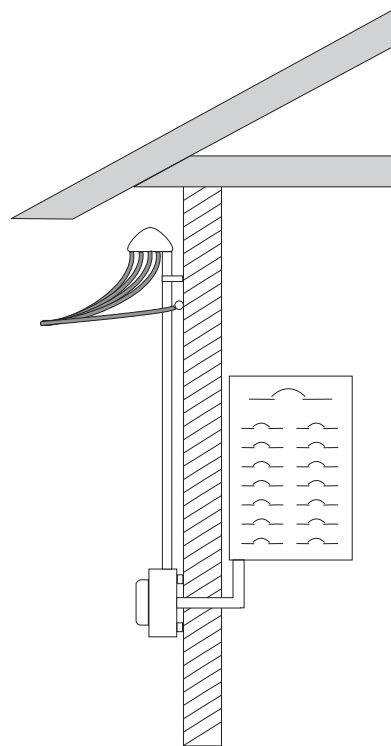

Main Breaker  
With Branch Circuits

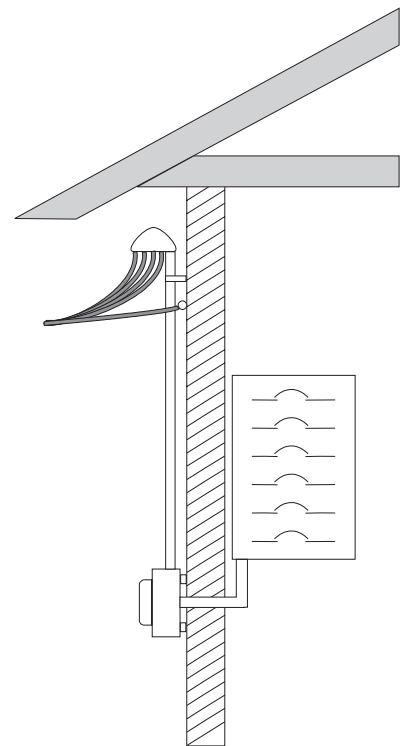

Main Lug Only  
With Six Service Disconnects

## Single-pole units and the six disconnect rule

*NEC Article 230-71b states that two or three single-pole switches or circuit breakers, capable of individual operation, shall be permitted on multiwire circuits, one pole for each ungrounded conductor, as one multiple disconnect, provided they are equipped with "handle ties" or a "master handle" to disconnect all conductors of the service with no more than six operations of the hand.*

It is important to note that the "six disconnect rule" refers to the number of disconnects and not the number of poles. For example, the main lug only panelboard shown below has 18 poles but only six circuit breakers. Three poles are mechanically linked together to form one disconnect device. In the illustrated configuration the service can be disconnected with no more than six operations of the hand. This arrangement meets the "six disconnect rule".

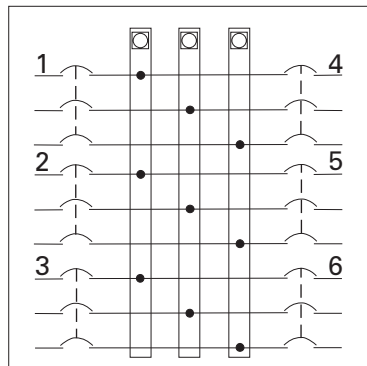

# Panelboard Grounding

Grounding is an important aspect of any electrical equipment and must be considered carefully. Article 250 of the *NEC* covers mandatory grounding requirements. The *National Electrical Code* defines ground as *a conducting connection, whether intentional or accidental, between an electrical circuit or equipment and the earth, or to some conducting body that serves in place of the earth.*

The following illustration, for example, shows the neutral (N) conductor of a wye-connected transformer connected to ground.

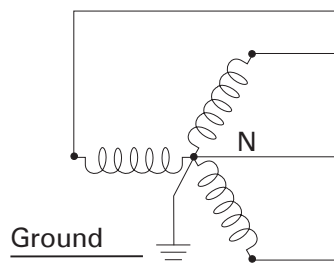

There are two objectives to the intentional grounding of electrical equipment:

- Keep potential voltage differentials between different parts of a system at a minimum which reduces shock hazard.
- Keep impedance of the ground path to a minimum. The lower the impedance the greater the current is in the event of a fault. The greater the current the faster an overcurrent device will open.

## Service entrance grounding

The circuit is grounded only at the service entrance, never at any downstream equipment. In the following illustration the neutral is grounded at the service equipment by connecting a grounding electrode conductor from the neutral (grounded conductor) to a grounding electrode. The neutral and the panelboard enclosure are bonded together at the service equipment so that the enclosure is also connected to ground through the grounding electrode connector.

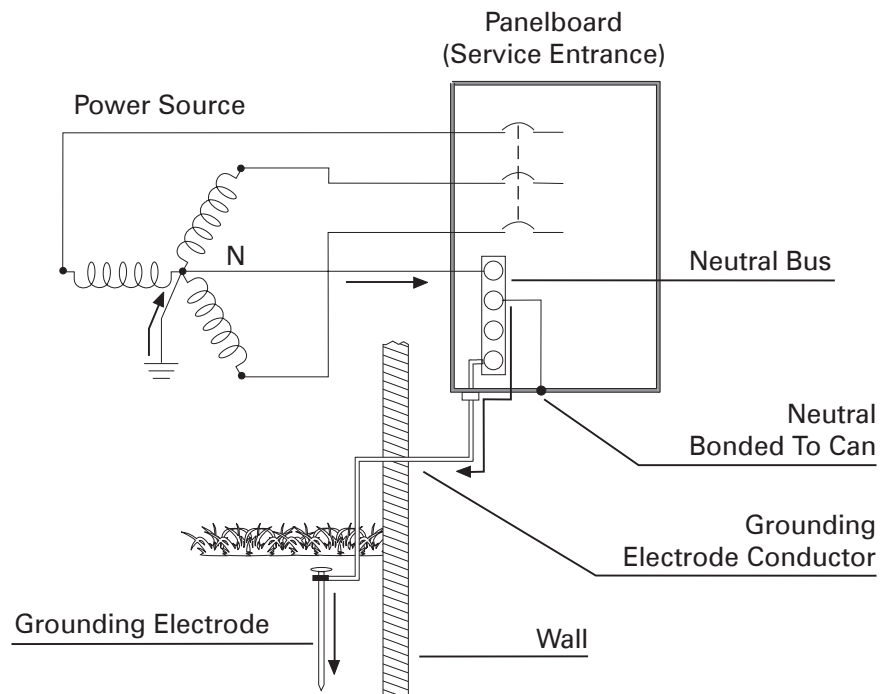

## Equipment grounding bus

A panelboard may also require an equipment grounding bus which is non-insulated and mounted inside the panelboard directly to the can. All feeder and branch circuit equipment that are connected to the equipment grounding bus are at the same potential as the panelboard can. Siemens panelboards come with an equipment grounding bus.

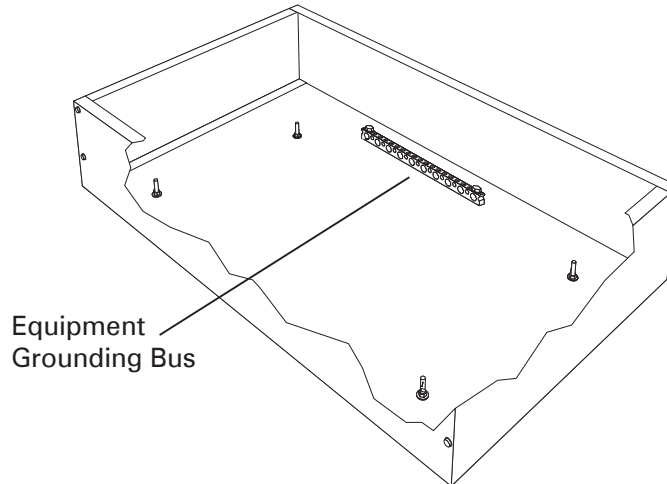

## Grounding downstream panelboards

The neutral (grounded conductor) is only connected to ground at the service entrance. Beyond the service equipment the neutral is always insulated. When a downstream panel is used the neutral is insulated in that panel. As shown in the following illustration the enclosure of the downstream panel is connected to ground through a grounding conductor back to the service equipment.

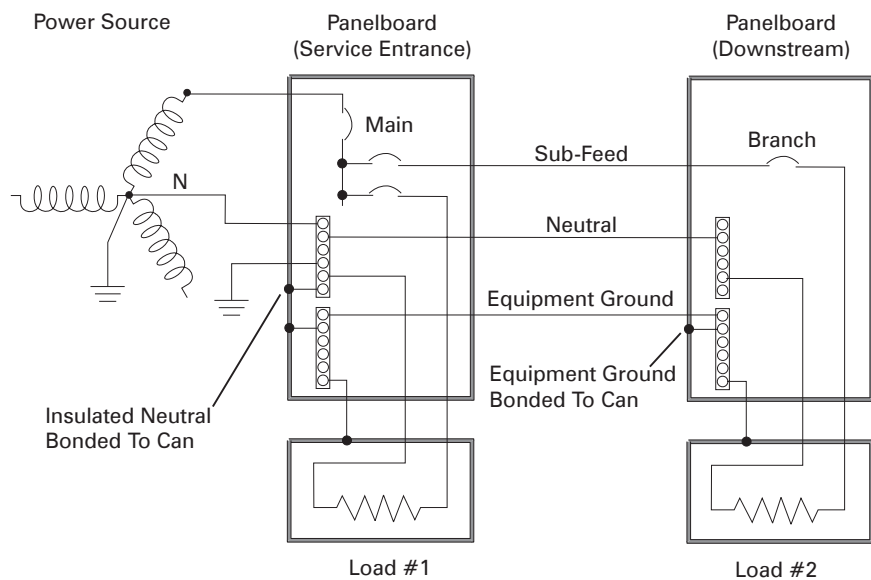

## Using the neutral with service entrance and downstream panelboards

In the following illustration load #2 has become shorted to its metal enclosure. Fault current is returned to the source through the path indicated. With a properly coordinated system the branch circuit breaker in the downstream panelboard will open removing the load from the power source. For a discussion of circuit breaker coordination refer to the STEP 2000 course, **Molded Case Circuit Breakers**.

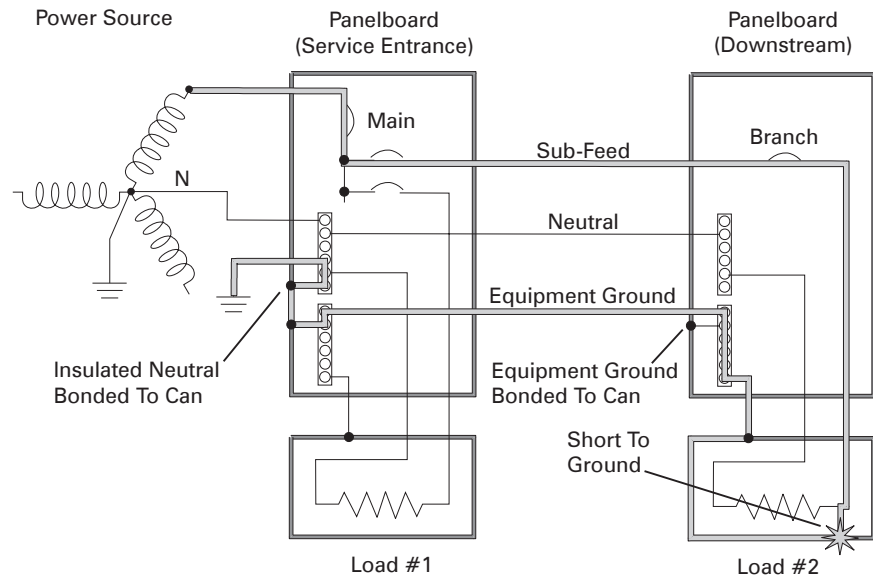

## Review 4

1. If the secondary of a four-wire, wye-connected transformer is 480 volts phase-to-phase, the phase to neutral voltage is \_\_\_\_\_ volts.
2. If the secondary of a four-wire, delta-connected transformer is 240 volts phase-to-phase, the phase to neutral voltage is  
\_\_\_\_\_ volts from A-N  
\_\_\_\_\_ volts from B-N  
\_\_\_\_\_ volts from C-N
3. According to *NEC* Article 230-71a, the maximum number of circuit breakers that can be used to disconnect and isolate the service from all other equipment is \_\_\_\_\_ .
4. \_\_\_\_\_ is the permanent joining of metallic parts to form an electrically conductive path.
5. The \_\_\_\_\_ conductor is grounded only at the service entrance equipment, never at any downstream equipment.

# Ground Fault Protection

In addition to ensuring equipment is properly grounded, ground fault protection for people and equipment is also a concern. *NEC Article 230-95 states that ground-fault protection of equipment shall be provided for solidly grounded wye electrical services of more than 150 volts to ground, but not exceeding 600 volts phase-to-phase for each service disconnecting means rated 1000 amperes or more.* Although ground-fault protectors are not required on service disconnects that are less than 1000 amperes, depending on the installation, they still may be desirable. Ground fault interrupters designed to provide life protection must open a circuit at 5 milliamps ( $\pm 1$  milliamp). Equipment protection must open a circuit when ground fault current reaches 30 milliamps. Ground fault protection is generally incorporated into a special type of circuit breaker.

## Ground-fault sensor around bonding jumper

One way a ground fault protector works is to install a sensor around the insulated neutral bonding jumper. When an unbalanced current from a line-to-ground fault occurs current will flow in the bonding jumper. When the current reaches the setting of the ground-fault sensor the shunt trip opens the circuit breaker, removing the load from the line.

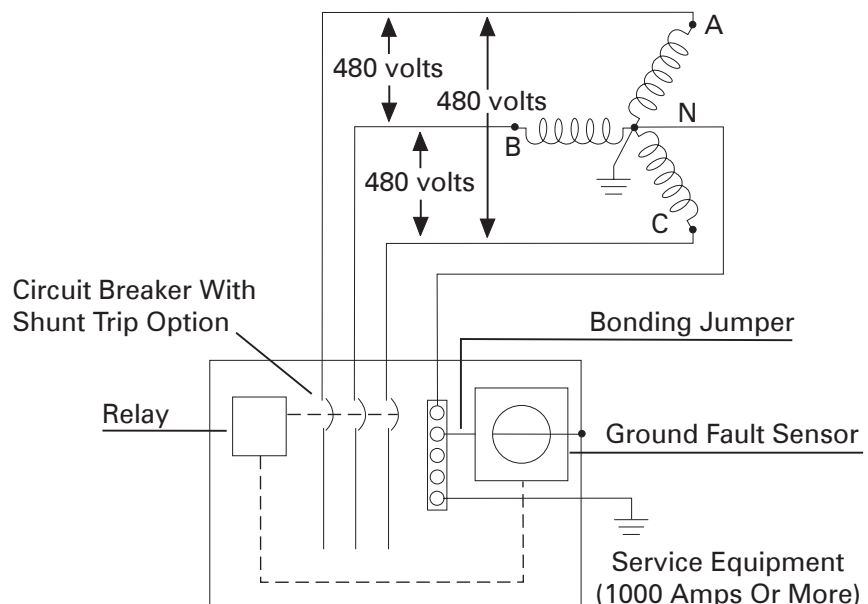

**Ground-fault sensor  
around all circuit  
conductors**

Another way a ground fault protector works is with a sensor installed around all the circuit conductors. During normal current flow the sum of all the currents is zero. However, a ground fault will cause an unbalance of the currents flowing in the individual conductors around the sensor. When this current reaches the setting of the ground-fault sensor the shunt trip opens the circuit breaker.

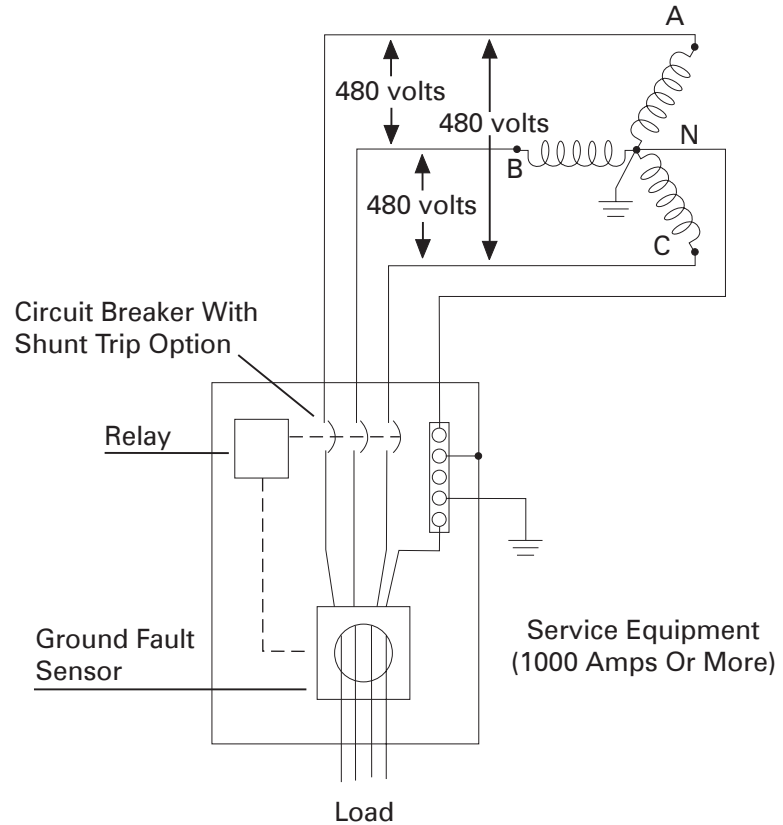

# Panelboard Ratings

When selecting panelboards and overcurrent protection devices it is extremely important to know both the maximum continuous amperes and available fault current. *NEC* article 110-9 states:

*Equipment intended to break current at fault levels shall have an interrupting rating sufficient for the system voltage and the current which is available at the line terminals of the equipment.*

*Equipment intended to break current at other than fault levels shall have an interrupting rating at nominal circuit voltage sufficient for the current that must be interrupted.*

## Full rating

There are two ways to meet this requirement. The full rating method is to select circuit protection devices with individual ratings equal to or greater than the available fault current. This means that, in the case of a building with 65,000 amperes of fault current available at the service entrance, every circuit protection device must be rated at 65,000 amperes interrupting capacity (AIC). In the following example, the main circuit breaker and each branch breaker is rated for 65,000 AIC.

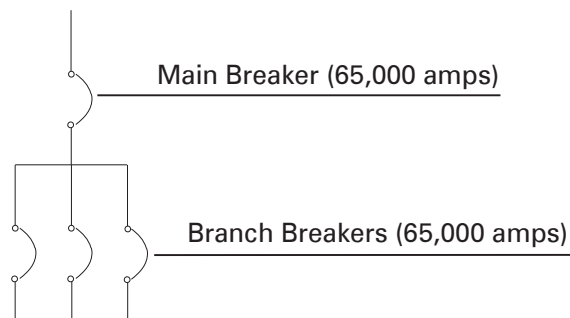

## Series-rated

The series-rated concept is that the main upstream circuit protection device must have an interrupting rating equal to or greater than the available fault current of the system, but subsequent downstream circuit protection devices connected in series can be rated at lower values. For example, a building with 42,000 amperes of available fault current might have the breaker at the service entrance rated at 42,000 AIC and additional downstream breakers rated at 18,000 AIC.

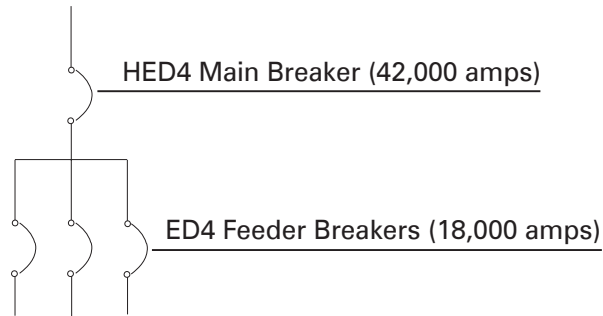

Series-rated breaker combinations must be tested in series in order to be UL listed. Siemens series-rated breakers are listed in the UL "Recognized Components Directory" (yellow books) Volume 1. Selected series-rated breakers are listed in the Speedfax catalog. Your Siemens sales engineer can provide more information on Siemens series-rated circuit breakers.

## Rating terms

There are three rating terms that need to be understood when selecting panelboards and appropriate circuit protection devices.

Withstand Rating	Refers to the level of fault current a piece of equipment can withstand without sustaining damage. Siemens panelboards have withstand ratings up to 200,000 amps.
Interrupting Rating	Refers to the current rating a protective device such as a fuse or circuit breaker can safely interrupt. Siemens molded case circuit breakers have interrupting ratings up to 200,000 amps.
Integrated Equipment	Refers to the interrupting rating of the lowest installed device, unless there is a series combination rating, not to exceed the withstand rating of the equipment.

## Integrated equipment short circuit rating

The term Integrated Equipment Short Circuit Rating refers to the application of series circuit breakers in a combination that allows some breakers to have lower individual ratings than the available fault current. This is permitted as long as the series combinations shown have been tested and certified by UL. The following table from the Speedfax catalog shows S1, S2 and SE assembled panelboards. An SE main breaker (MB) panelboard, for example, can have a main breaker with a maximum continuous ampere rating of 600 amps, branch circuit breakers with ratings from 15-125 amps, and if used on 480Y/277V has a short circuit interrupting rating of 150,000 amps.

Description	Maximum Volts AC	Mains Rating Amperes		Branch Rating Amperes	Max Interrupting Rating Symmetrical Amperes		
		MLO	MB		240	480	600
<b>Circuit Breaker-Assembled</b>							
S1	240	600	600	15-100	200,000	N/A	N/A
S2	480Y/277V 600Y/347V	600	600	15-100	200,000	100,000	100,000
SE	600V	600	600	15-125	200,000	150,000	150,000

MLO = Main Lug Only  
MB = Main Breaker

To select appropriate main and branch circuit breakers refer to the integrated short circuit ratings tables in the Speedfax catalog.

## Review 5

1. Ground fault protection is required when service disconnecting devices are rated at \_\_\_\_\_ or more.
2. The \_\_\_\_\_ rating method requires selecting circuit protection devices with individual ratings equal to or greater than the available fault current.
3. Devices selected for integrated equipment application must be tested and certified by \_\_\_\_\_.
4. \_\_\_\_\_ rating refers to the level of fault current a piece of equipment can withstand without sustaining damage.
5. \_\_\_\_\_ rating refers to the current rating a protective device such as a fuse or circuit breaker can safely interrupt.
6. \_\_\_\_\_ \_\_\_\_\_ refers to the interrupting rating of the lowest installed device, unless there is a series rating, not to exceed the withstand rating of the equipment.

# S1, S2, And SE Lighting Panelboards

The smallest Sentron™ panelboards are the S1, S2, and SE panelboards. They are available with 18, 30 or 42 circuits.

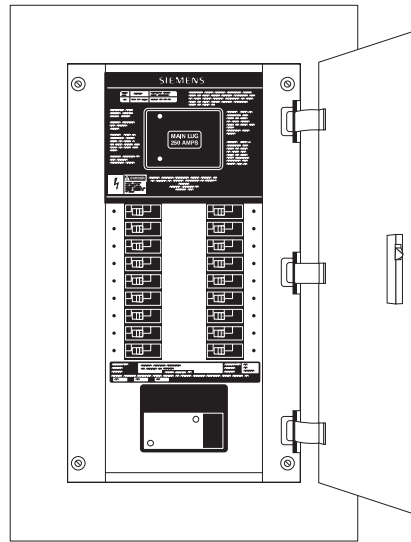

18 Circuit S1 Panelboard

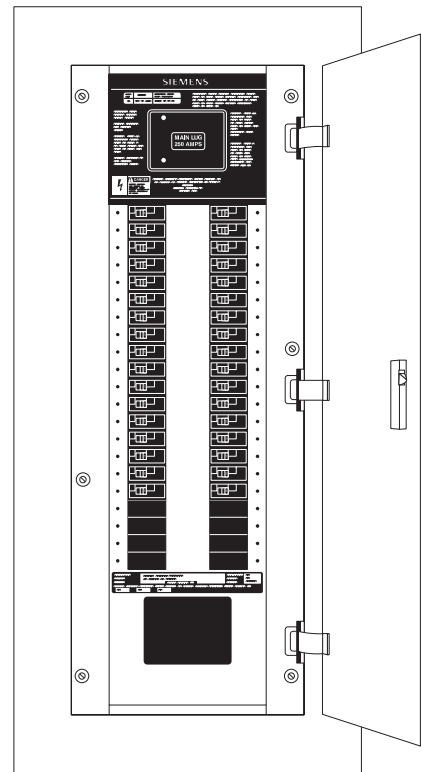

42 Circuit S2 Panelboard

## Dimensions

The following chart shows the dimensions of the S1, S2, and SE panelboards. Width and depth varies with the current rating. Height varies with the number of circuits. The main breaker or lug module do not affect panelboard height.

Panelboard	Width	Depth	Circuits	Height
S1/S2 $\leq$ 250 Amps	20"	5.75"	18	32"
			30	38"
			42	44"
S1/S2 $>$ 250 Amps	24"	7.75"	42	68"
SE $\leq$ 250 Amps	24"	7.75"	30	44"
			42	50"
SE $>$ 250 Amps	24"	7.75"	42	68"

## S1 panelboard

The S1 panelboard is available as a main circuit breaker or a main lug unit. A standard feature of the S1 panelboard is field convertible mains. This means that the panelboard can be changed from a main circuit breaker to a main lug only in the field, without increasing box height. Another advantage to the S1 panelboard is the ability to change in the field whether the panelboard is top or bottom fed. This is accomplished by simply inverting the panelboard interior or reinstalling the main breaker or lug module on the opposite end of the panelboard. S1 panelboards also feature concealed fasteners and hinges with a flush door lock.

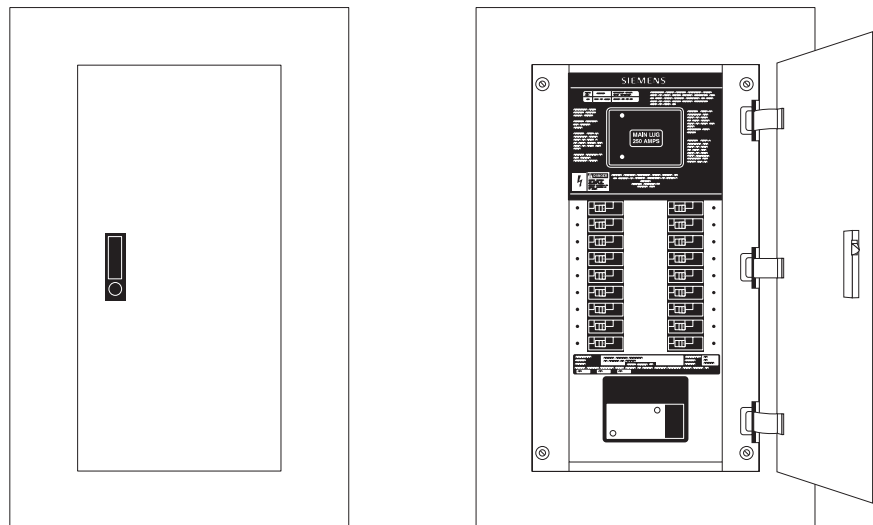

The following information gives various S1 rating ranges. Refer to the Speedfax catalog when ordering specific panelboards. The type of branch, main and subfeed breakers vary with the panelboard and application requirements. Only one subfeed breaker is allowed in the S1 panelboard, except 400 A and 600 A panelboards can have two QJ subfeed breakers.

Voltage	120/240, 208Y/120
System	Single-Phase, Three-Wire (1Ø3W), Three-Phase, Four-Wire (3Ø4W)
Main Lug Only	125 A, 250 A, 400 A, 600 A
Main Circuit Breaker	100 A, 125 A, 225 A, 250 A, 400 A, 600 A
Subfeed Breaker	ED4, HED4, HHED6, QJ2, QJH2, QJ2-H, FXD6, HFD6, JXD6, HJD6, LXD6, HLD6
Branch Circuit Breakers	BL, BLH, HBL
Integrated Equipment Short Circuit Rating	10,000 - 200,000 AIR

## S2 panelboards

S2 panelboards are similar to S1 panelboards with a few exceptions. The S2 is designed to operate at voltages of 480Y/277 VAC and 600Y/347 VAC. The S2 is suitable for 3-phase, 4-wire systems. The S2 panelboard features the same convertible mains, concealed fasteners, hinges and flush door lock as the S1.

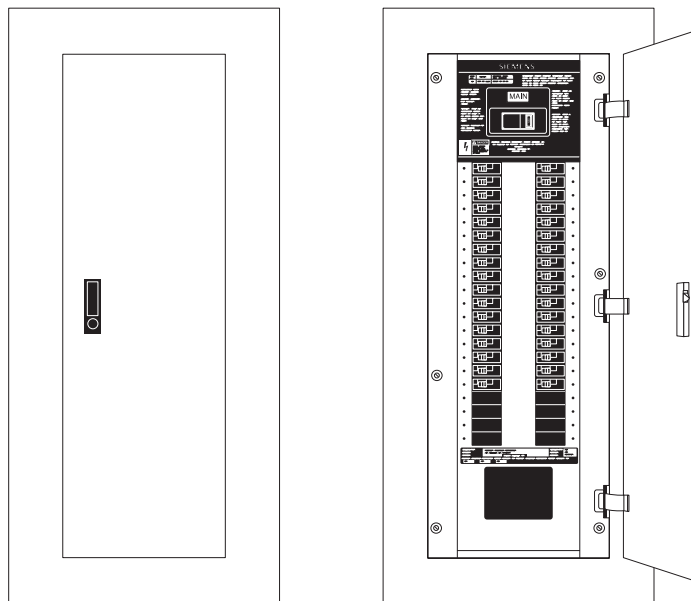

The following information gives various S2 rating ranges. Refer to Siemens Speedfax when ordering specific panelboards. The type of branch, main and subfeed breakers vary with the panelboard and application requirements. Only one subfeed breaker is allowed in the S2 panelboard, except 400 A and 600 A panelboards can have two QJ subfeed breakers.

Voltage	480Y/277, 600Y/347
System	3Ø4W
Main Lug Only	125 A, 250 A, 400 A, 600 A
Main Circuit Breaker	100 A, 125 A, 225 A, 250 A, 400 A, 600 A
Subfeed Breaker	ED4, ED6, HED4, HHED6, FXD6, HFD6, JXD6, HJD6, LXD6, HLD6
Branch Circuit Breakers	BQD
Integrated Equipment Short Circuit Rating	10,000 - 200,000 AIR

## SE panelboards

SE panelboards are similar to S2 panelboards with a few exceptions. The SE is designed to operate at a maximum voltage of 600 VAC/250 VDC. The SE is suitable for 1-phase, 3-wire, 3-phase, 3-wire, and 3-phase, 4-wire systems. The SE panelboard features the same convertible mains, concealed fasteners, hinges and flush door lock as the S1 and S2.

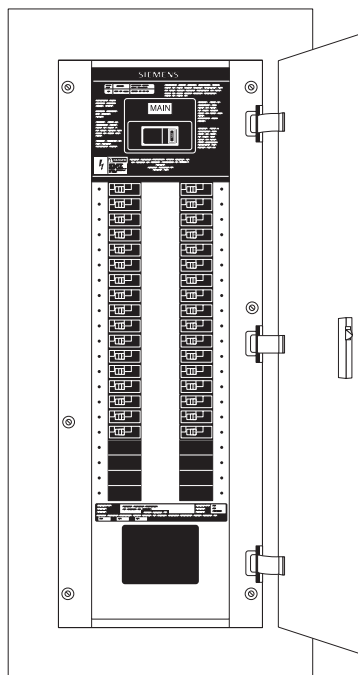

The following information gives various SE rating ranges. Refer to Siemens Speedfax when ordering specific panelboards. The type of branch, main and subfeed breakers vary with the panelboard and application requirements. Only one subfeed breaker is allowed in the SE panelboard, except 400 A and 600 A panelboards can have two QJ subfeed breakers.

Voltage	600 VAC/250 VDC
System	1Ø3W, 3Ø3W, 3Ø4W
Main Lug Only	125 A, 250 A, 400 A, 600 A
Main Circuit Breaker	125 A, 225 A, 250 A, 400 A, 600 A
Subfeed Breaker	FXD6, HFD6, JXD6, HJD6, LXD6
Branch Circuit Breakers	ED4, ED6, HED4, HHED6
Integrated Equipment Short Circuit Rating	10,000 - 200,000 AIR

# Transient Protection System (TPS)

## Need for surge protection

Transients voltage spikes appear on an electrical system as a result of lightning and switching transients. These transients are capable of destroying sensitive electronic equipment in commercial and industrial applications.

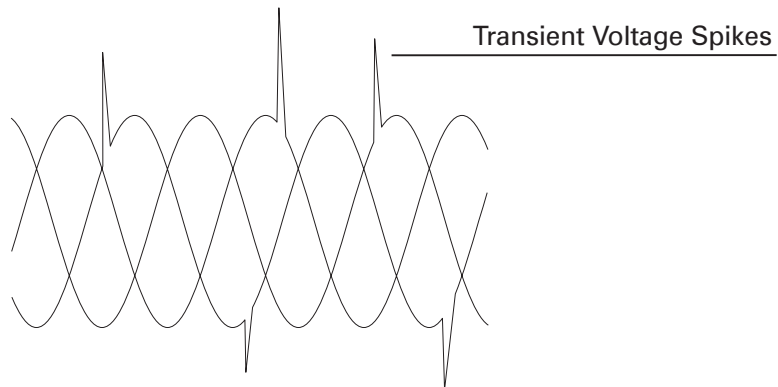

The most damaging voltage spikes are caused by lightning strikes. Although lightning strikes on high voltage lines are generally dissipated by utility transmission and arresters, a lightning strike on a power line several miles away still has the potential to cause extensive electrical damage. Damage to expensive electrical equipment can be either instantaneous or cumulative.

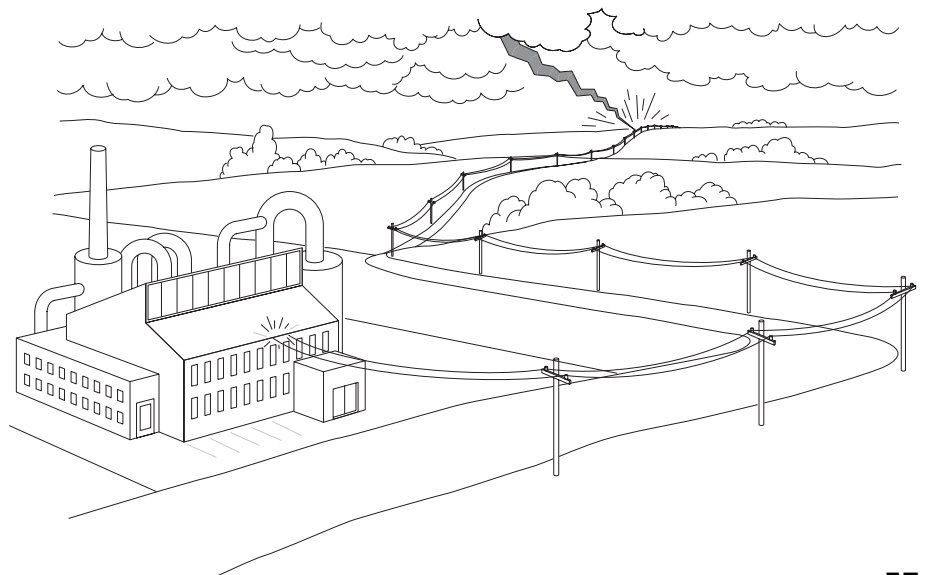

## Number of thunderstorms

Worldwide there are 44,000 thunderstorms each day, 2000 thunderstorms at any given time, and 1000 lighting flashes per second. A typical lightning strike consists of 25,000 amps at 30 million volts. The following map shows the approximate mean annual number of days with thunderstorms in the United States.

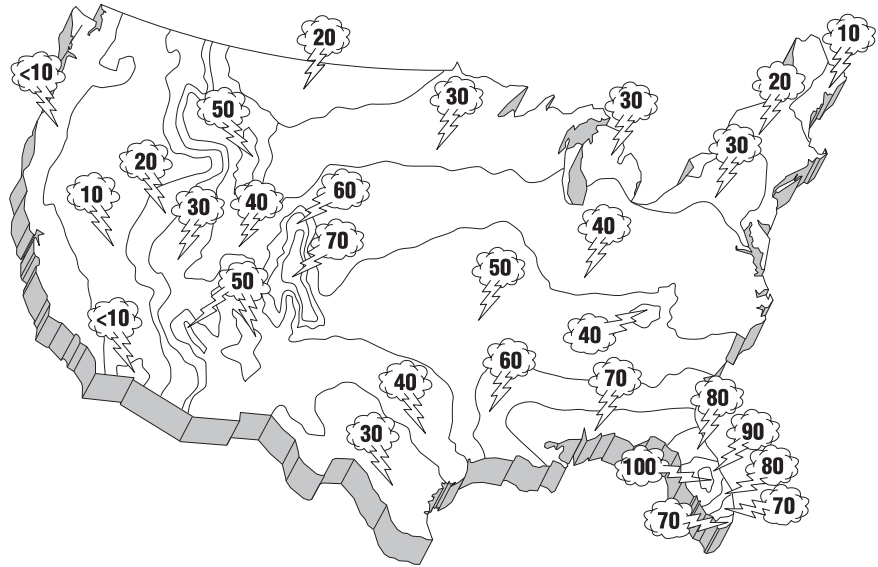

## TPS

Computers and other office equipment are susceptible to the high energy levels caused by an electrical surge, whether it is caused by electrical equipment or lightning. Any component between the source of the surge and ground can be damaged. Siemens TPS transient protection system clamps these damaging voltage spikes before they damage expensive and sensitive equipment.

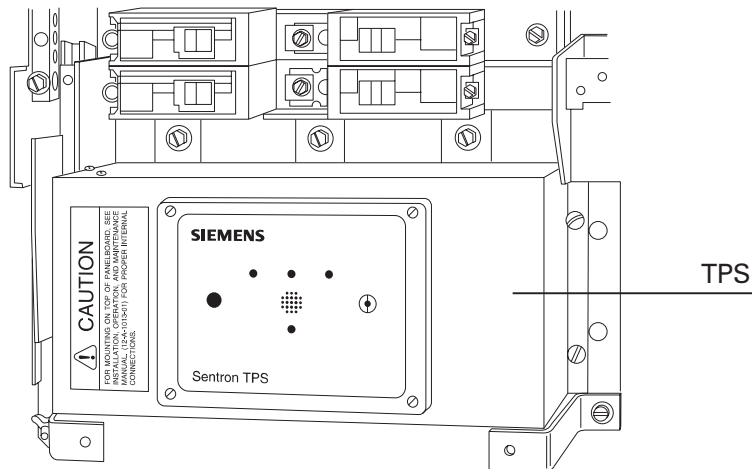

## Installation

The TPS is bolted directly to the bus bars within the S1, S2, and SE panelboards. Purchased “over the counter” and utilizing a field installation kit, the TPS transient voltage protection system can easily be mounted in existing S1, S2, and SE lighting panelboards. LEDs indicate that the device is working and provide voltage and diagnostic monitoring. There is an audible alarm and test button. Options include a surge counter and a remote monitoring device.

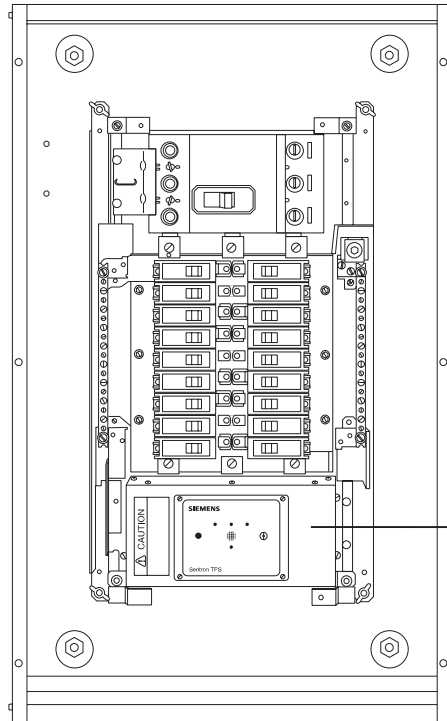

TPS with LED indicators, audible alarm with silence switch, and test button.

## Clamping voltage

Clamping voltage is the amount of voltage allowed across a surge suppression device when it is conducting a specific current created by a surge. The following chart indicates clamping voltage for the Siemens TPS.

System Voltage	Line-to-Neutral	Neutral-to-Ground	Line-to-Ground
120/240 1Ø3W	500 V	500 V	500 V
208Y/120V 3Ø4W	500 V	500 V	500 V
480Y/277V 3Ø4W	1000 V	1000 V	1000 V

## Peak current rating

Peak current rating specifies the maximum current that a protective device can withstand from a single surge. The Siemens TPS can withstand impulse currents as high as 80,000 amps or 160,000 amps, depending on the model.

## Review 6

1. The maximum number of circuits available on the S1, S2, and SE lighting panelboards is \_\_\_\_\_ .
2. One way to convert an S1, S2, or SE from top to bottom feed is to relocate the main breaker or lug module. Another way is to \_\_\_\_\_ the interior.
3. The maximum voltage of an S1 panelboard is \_\_\_\_\_ volts.
4. The maximum integrated equipment short circuit rating of an S2 panelboard is \_\_\_\_\_ AIR.
5. The maximum voltage rating for an SE panelboard is \_\_\_\_\_ VAC.
6. The \_\_\_\_\_ \_\_\_\_\_ \_\_\_\_\_ is used to protect sensitive electrical equipment from damaging voltage spikes.

# S4 And S5 Power Panelboards

S4 and S5 power panelboards are similar in design and features, but vary in the ratings available. S4 and S5 panelboards will accept various circuit breakers and fusible switches. The S4 will accept branch circuit breakers up to 600 amps. The S5 will accept branch circuit breakers up to 1200 amps.

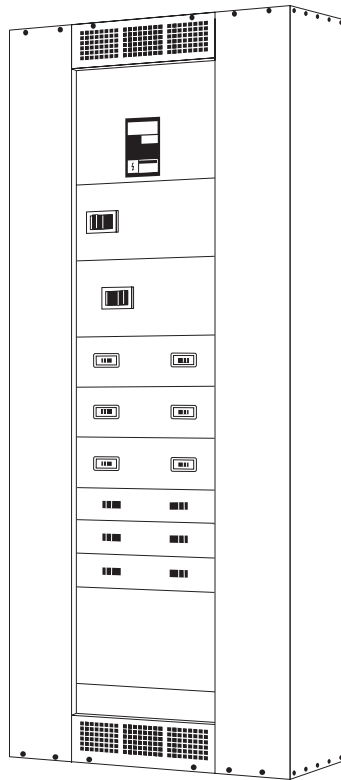

## S4 panelboard ratings

The following information gives various S4 rating ranges. Refer to Siemens Speedfax when ordering specific panelboards. Branch circuit breakers vary depending on the panelboard rating.

Voltage	600 V
System	1Ø3W, 3Ø4W, 3Ø3W
Main Lug Only	400 A - 1200 A
Main Circuit Breaker	400 A - 600 A
Main Fusible Switch	100 A - 200 A
Branch Circuit Breakers	All 15 A - 600 A
Integrated Equipment Short Circuit Rating	200,000 AIR Maximum

## S5 panelboard ratings

The following information gives various S5 rating ranges. Refer to Siemens Speedfax when ordering specific panelboards. Branch circuit breakers vary depending on the panelboard rating.

Voltage	600 V
System	1Ø3W, 3Ø4W, 3Ø3W
Main Lug Only	800 A, 1000 A, 1200 A
Main Circuit Breaker	800 A, 1200 A
Main Fusible Switch	400 A - 1200 A
Branch Circuit Breakers	All 15 A - 1200 A
Integrated Equipment Short Circuit Rating	200,000 AIR Maximum

## Dimensions

The S4 is only 32" wide by 10" deep. This simplifies handling and installation. The enclosure height varies with the type and number of circuits required. The enclosure heights are 60", 75" and 90". A one piece door is available which allows for locking and flush mounting.

The S5 is 38" wide by 12.75" deep in a NEMA Type 1 enclosure. The S5 is 38" wide by 14.25" deep in a NEMA Type 3R or 12 enclosure. The enclosure height varies with the type and number of circuits required. The enclosure heights are 60", 75" and 90".

# F1 And F2 Fusible Panelboards

F1 and F2 power panelboards normally use fusible switches for overcurrent protection instead of circuit breakers. F1 and F2 have main lug ratings up to 1200 A. When main protection is required, a fusible switch with ratings of 100 and 200 amps should be used for F1 panelboards or 400 to 1200 amps for F2 panelboards.

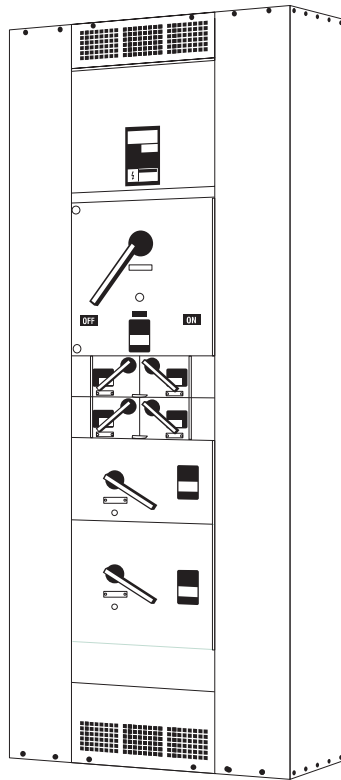

## Fusible switch

Siemens branch fusible switches are available with ampere ratings from 30 to 1200 amps.

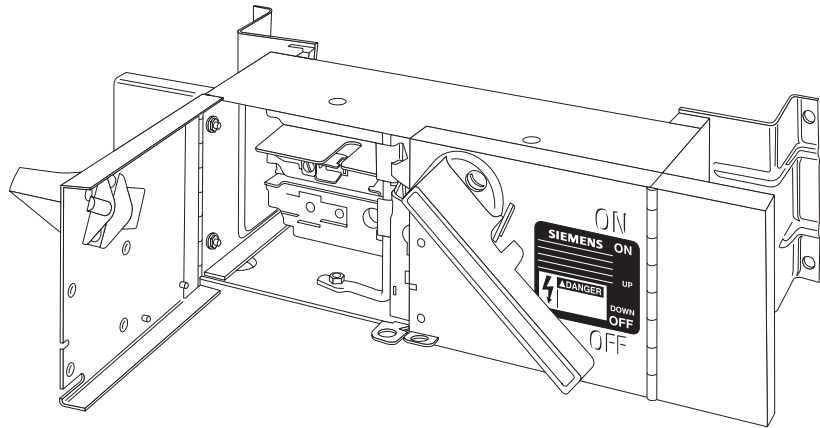

Siemens fusible switches can be fitted with Class J, L, RK1, RK5 or T fuses. The following illustration shows a Class R fuse holder.

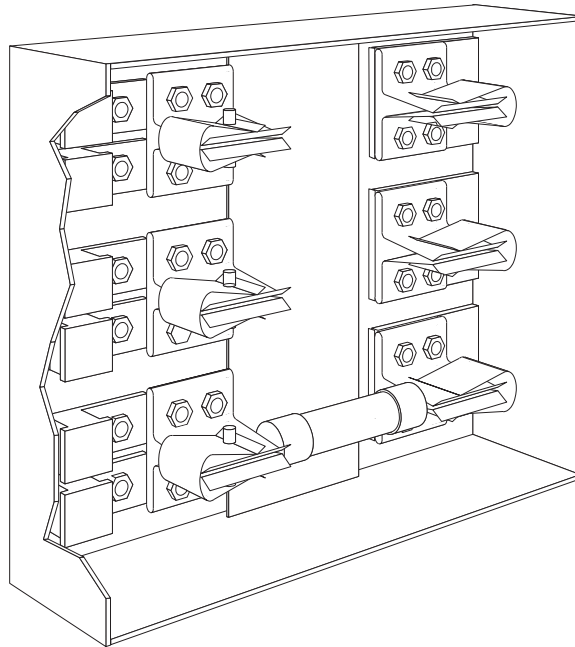

## Clampmatic action

Siemens Vacu-Break® fusible switches, through 600 A, feature a Clampmatic® action. This action holds the current carrying contact surfaces in a vise-like grip. Heat build-up due to current is minimized. When the switch is moved to the "OFF" position the movable contact snaps from between the jaws providing a quick, clean break. Twin arcs are produced which are smaller and extinguish quicker than a single arc produced by other designs.

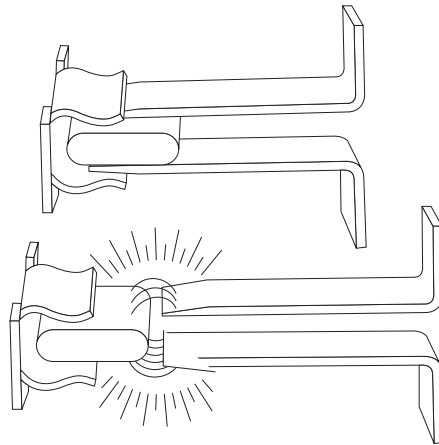

## Enclosed arc chamber

The contacts are surrounded by an enclosed arc chamber which absorbs much of the heat from the arcing. The enclosed chamber helps limit oxygen which aids the cooling and rapid extinguishing of the arcs.

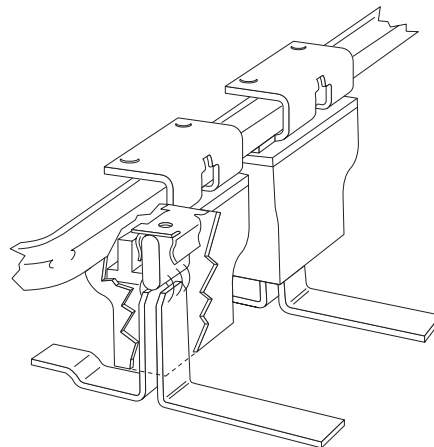

## High contact pressure switch

A high contact pressure (HCP) switch is used on switches rated for 800 A and 1200 A. The HCP switch does not use the Vacu-Break® design.

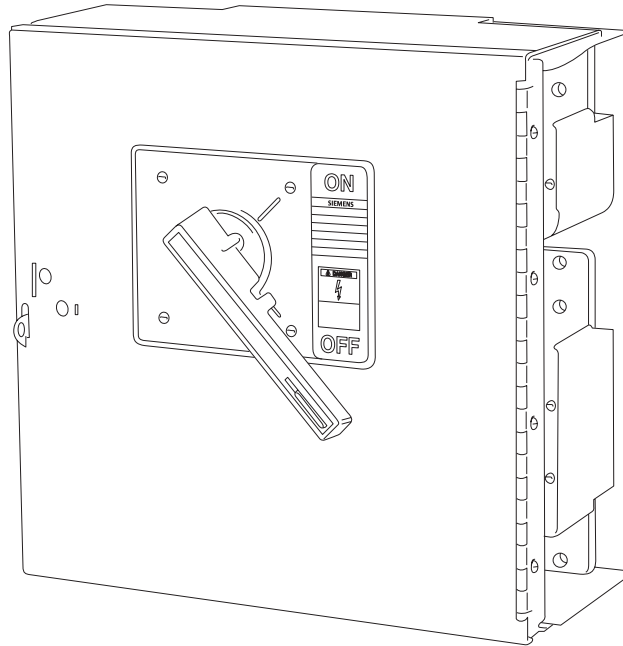

## F1 panelboard ratings

The following information gives various F1 rating ranges. Panelboards are still referred to as main breaker or main lug only even though fusible disconnects are used. Refer to Siemens Speedfax when ordering specific panelboards.

Voltage	600 V
System	1Ø3W, 3Ø4W, 3Ø3W
Main Lug Only	400 A - 1200 A
Main Circuit Breaker	400 A - 600 A
Main Fusible Switch	100 A - 200 A
Branch Circuit Protection	30 A - 200 A
Integrated Equipment Short Circuit Rating	200,000 AIR Maximum

## F2 panelboard ratings

The following information gives various F2 rating ranges. Refer to Siemens Speedfax when ordering specific panelboards.

Voltage	600 V
System	1Ø3W, 3Ø4W, 3Ø3W
Main Lug Only	800 A - 1200 A
Main Circuit Breaker	800 A - 1200 A
Main Fusible Switch	400 A - 1200 A
Branch Circuit Protection	30 A - 1200 A
Integrated Equipment Short Circuit Rating	200,000 AIR Maximum

## Dimensions

The F1 is only 32" wide by 10" deep. The enclosure height varies with the type and number of circuits required. The enclosure heights are 60", 75" and 90".

The F2 is 38" wide by 12.75" deep in a NEMA Type 1 enclosure. The F2 is 38" wide by 14.25" deep in a NEMA Type 3R or 12 enclosure. The enclosure height varies with the type and number of circuits required. The enclosure heights are 60", 75" and 90".

# Telephone And Equipment Panelboards

Siemens also manufactures telephone and equipment cabinets which conform to requirements of Underwriters Laboratories, Inc. Cabinets are 5.75" deep, 20 or 24" wide and vary in height from 23 to 65". All telephone and equipment cabinets are preceded by the letters "TC" in the catalog number. The catalog number also reflects the cabinet height. For example, "TCS23B" is a telephone and equipment cabinet that is 23" in height.

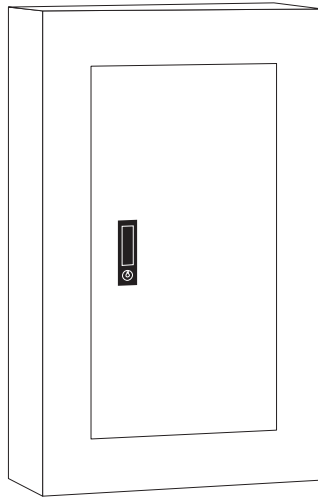

# Seismic Rated Panelboards

Seismic activity occurs throughout the United States and the world. The Uniform Building Code (UBC) specifies ratings for the United States. The following seismic zone map roughly identifies seismic activity areas in the United States. Areas in zones with higher numbers experience greater seismic activity than areas in zones with lower numbers.

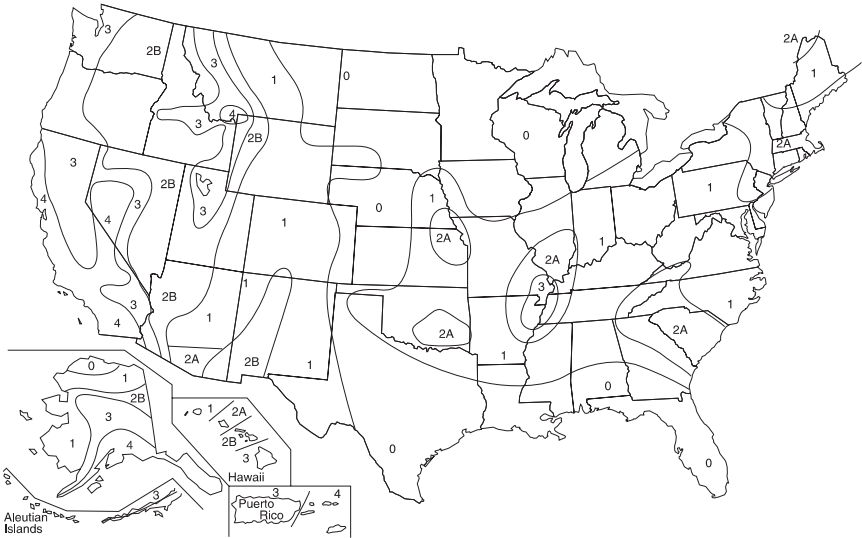

Siemens panelboards have undergone extensive seismic testing in order to obtain third party certification. Siemens panelboards will operate in zones 0, 1, 2A, and 2B with no modification. Panelboards that require zone 3 and 4 ratings are available with standard lead times.

Product	UBC Seismic Zone					
	0	1	2A	2B	3	4
S1, S2, SE S4, S5 F1, F2	Standard				Optional	

# Accessories

Accessories add to the performance of a panelboard or adapts the panelboard for specific application requirements. Various accessories are available for Siemens panelboards.

## Shunt trip

Some accessories modify the circuit breaker. For example, it is sometimes necessary to trip a breaker from a remote location. If someone were to get caught in a piece of machinery, anyone else can push a “panic button” tripping the breaker. One or all critical circuit breakers may be tripped at the push of a button from a distant control point by use of a shunt trip device. The shunt trip may be part of the main breaker which will shut off the entire panelboard, or part of a branch breaker. The shunt trip device consists of a coil in series with a limit switch. When the circuit breaker contacts are closed, the limit switch is closed. Depressing a customer-supplied pushbutton energizes the shunt trip coil, causing the breaker’s mechanical latch to disengage the trip mechanism and opening the circuit breaker’s contacts. When the circuit breaker’s contacts open, the limit switch also opens, removing power from the shunt trip coil. As with any trip, the breaker must be reset manually.

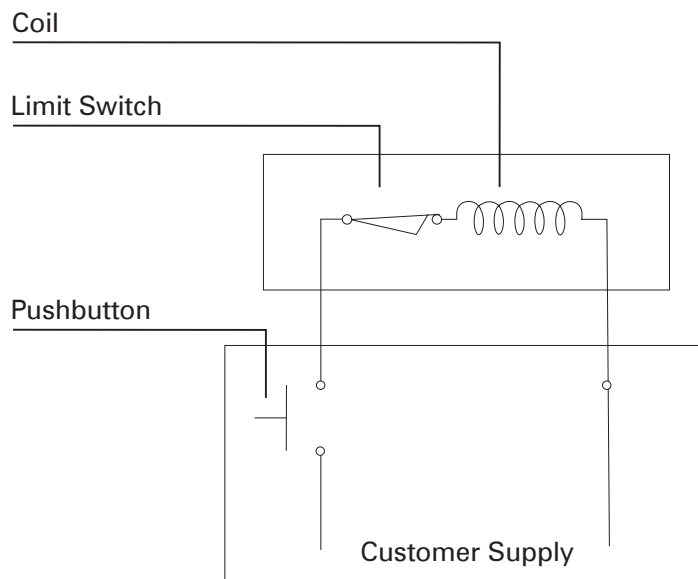

The following illustration shows the shunt trip being mounted on its associated breakers.

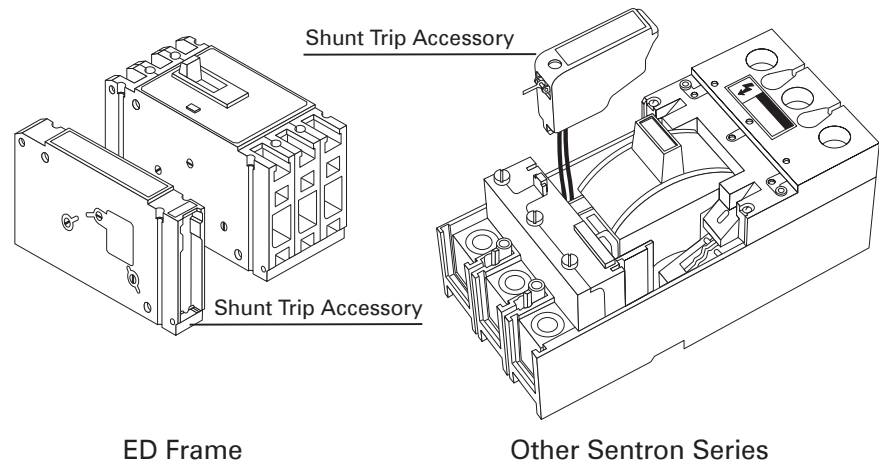

### Time clocks

Tork, Sangamo or Paragon time clocks are available as an accessory. Time clocks are available in 1 or 2-pole, single or double throw devices, or 3-pole, single throw. They are rated for a maximum of 277 volts.

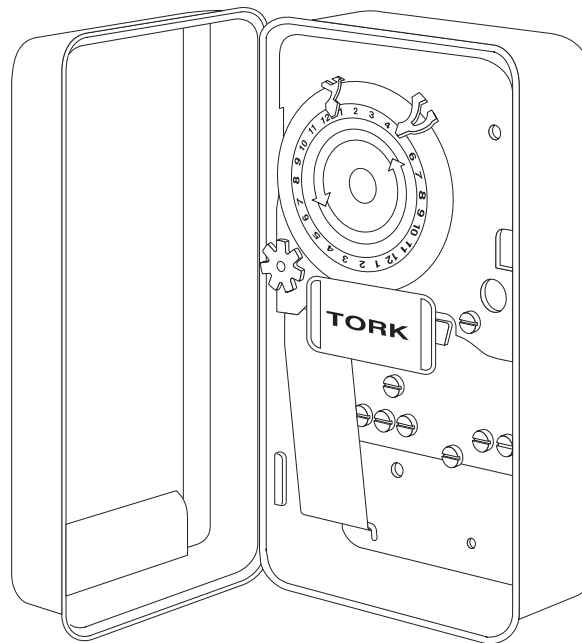

Tork Time Clock

A time clock can be used to turn a branch circuit or an entire panelboard on and off at predetermined times. In the following illustration, for example, a time clock connected to a panelboard is used to turn outside lights on and off on a small commercial building.

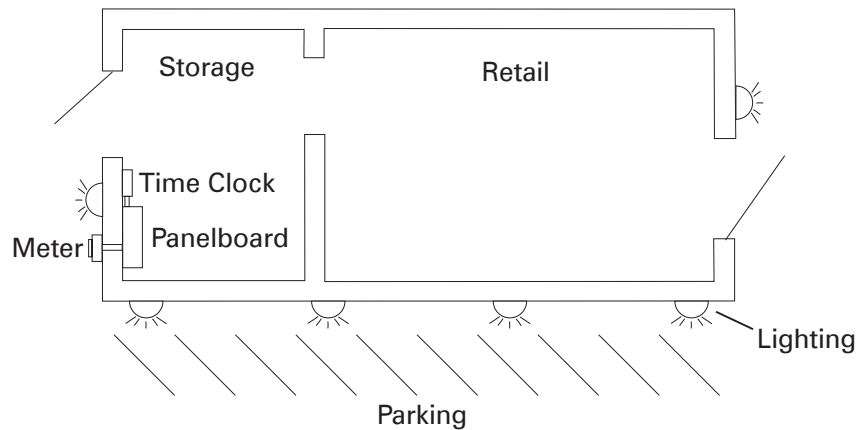

### Remote control switches

ASCO 920 switches are mechanically held, two- or three-pole remote control switches may be used as a main circuit disconnect device when an application calls for a switch to daily turn blocks of lighting on and off. ASCO 920 switches are available in 30, 60, 75, 100, 150, 200 and 225 amperes. Siemens also has a type CLM switch (not shown) which is a mechanically held, 20 amp, remote control unit, suitable for all types of lighting loads. It is available in 2, 3, 4, 6, 8, 10 and 12 poles.

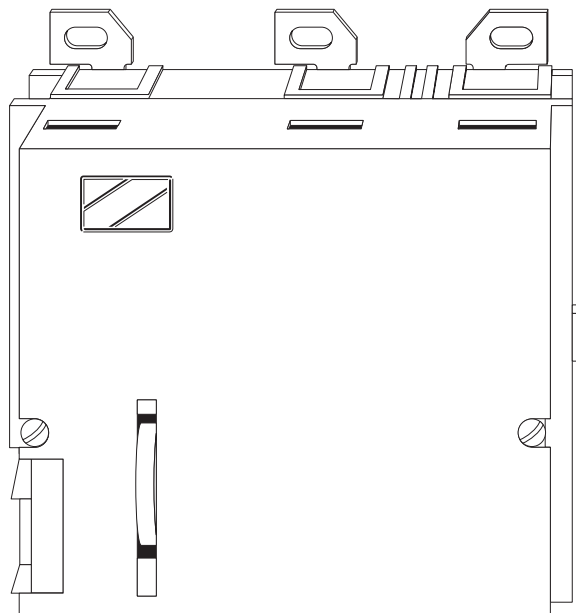

Remote Control Switch

# Catalog Numbers

To help identify each type of panelboard a catalog number is assigned. The catalog number provides a description of the panelboard. There are eight parts to the standard Sentron™ Series panelboard catalog number. The following figure illustrates a typical catalog number.

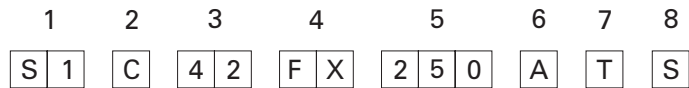

## Part 1

Part 1 identifies the type of panel. Panelboard are available in S1, S2, SE, S4, S5, F1 and F2 types. The sample panelboard catalog number shown is an S1 panelboard.

## Part 2

Part 2 identifies the voltage and system. The following table shows voltage and system configurations available. The last column identifies the system. 1Ø3W, for example, is a single-phase, three-wire.

A	= 120/240V	1Ø3W	(S1, SE, S4, S5, F1, F2)
B	= 240/120V	3Ø4W	(SE, S4, S5, F1, F2)
C	= 208Y/120V	3Ø4W	(S1, SE, S4, S5, F1, F2)
D	= 240V	3Ø3W	(SE, S4, S5, F1, F2)
E	= 480Y/277V	3Ø4W	(S2, SE, S4, S5, F1, F2)
F	= 480V	3Ø3W	(SE, S4, S5, F1, F2)
G	= 600V	3Ø3W	(SE, S4, S5, F1, F2)
L	= 600Y/347V	3Ø4W	(S2, SE, S4, S5, F1, F2)
N	= 120 VDC	2W	(SE, S4, S5, F1, F2)
O	= 250 VDC	2W	(SE, S4, S5, F1, F2)

The panelboard identified in the panelboard example is a 208Y/120V, 3Ø4W. This indicates it is rated for a 208 volt wye-connected secondary. There are 208 volts phase-to-phase and 120 volts phase-to-neutral. It is a 3-phase (3Ø) 4-wire (4W) system.

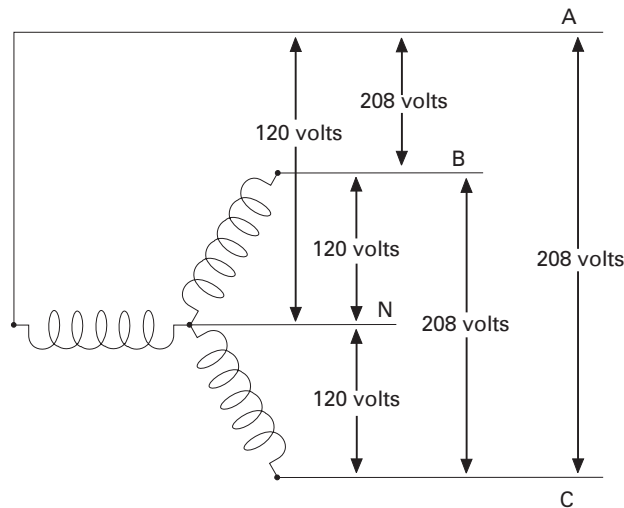

**Part 3**

Part 3 indicates the number of circuits in an S1, S2 or SE type panelboard. If the panelboard is an S4, S5, F1 or F2 type this number represents the enclosures height in inches. In this example the panelboard is an S1. There are 42 circuits.

**Part 4**

Part 4 indicates whether the panelboard is a main breaker (2-digit code varies for each different circuit breaker), main lug (ML) or main switch (MS). In this example the panelboard is an FXD6 main breaker (FX).

**Part 5**

Part 5 indicates the panelboard current rating. The example panelboard is rated for 250 amps.

**Part 6**

Part 6 indicates the bus material. The following table shows bus materials available. In this example the panelboard has standard aluminum bus bars.

- A = Tin Plated Aluminum Temp Rated (standard)
- B = 750A/in<sup>2</sup> Aluminum (optional)
- C = Copper Temp Rated (optional)
- D = 1000A/in<sup>2</sup> Copper (optional)
- E = Silver Plated Copper (optional)

**Part 7**

Part 7 indicates whether feed location is from the top (T) or bottom (B). In this example the panelboard is top fed.

**Part 8**

Part 8 indicates whether the panelboard is surface mounted (S) or flush mounted (F). In this example the panelboard is surface mounted.

# Information Needed To Order Panelboards

When ordering a panelboard several questions need to be answered.

1. What is the system (voltage, phases, number of wires)?
2. What is the AIC rating (ampere interrupting capacity)?
3. What is the NEMA Type enclosure desired?
4. How many circuits are required?
5. Does the panelboard need to be suitable for service entrance?

Suitable for use on service entrance Labels (SUSE) are available provided *NEC* requirements are met. A main lug only panelboard, for example, can only have a maximum of 6 breakers or it violates the 6 disconnect rule.

6. What amperage is the panelboard rated at?
7. Will the panelboard be main breaker or main lug only?
8. What special modifications are needed?
9. What is the shipping time frame?
10. Is the panelboard to be top or bottom fed?
11. Is the panelboard to be surface or flush mount?
12. Is the panelboard assembled or unassembled?

## Review 7

1. The S4 panelboard will accept branch circuit breakers up to \_\_\_\_\_ amps.
2. The maximum main circuit breaker available for the S5 panelboard is \_\_\_\_\_ amps.
3. F1 and F2 panelboards use \_\_\_\_\_ switches for branch circuit protection.
4. The enclosed arc chamber limits \_\_\_\_\_ which aids in the cooling and rapid extinguishing of the arcs.
5. The maximum main circuit breaker available for F1 panelboards is rated for \_\_\_\_\_ amps.
6. A \_\_\_\_\_ accessory mounts to the circuit breaker and is used to trip a breaker from a remote location.
7. A letter \_\_\_\_\_ in part 2 of a catalog number would indicate a 120/240 volt, 1-phase, 3-wire system.
8. The number 42 in part 3 of a catalog number for an S1 panelboard indicates the panelboard
  - a. contains 42 circuits
  - b. is 42 inches tall
  - c. is 42 inches wide

# Review Answers

- Review 1** 1) distribution system; 2) b; 3) 384; 4) lighting and appliance because there are less than 42 poles and more than 10% are rated 30 amps or less.
- Review 2** 1) bus; 2) current; 3) overload, short circuit, ground; 4) 50,000 amps; 5) R; 6) amps, voltage; 7) deadfront and trim; 8) 1.
- Review 3** 1) breaker, lug; 2) horizontally or vertically; 3) lug only; 4) feed-through; 5) 384-16; 6) two.
- Review 4** 1) 277; 2) 120 A-N, 208 B-N, 120 C-N; 3) 6; 4) Bonding; 5) neutral.
- Review 5** 1) 1000 A; 2) full; 3) UL; 4) Withstand; 5) Interrupting; 6) Integrated Equipment.
- Review 6** 1) 42; 2) invert; 3) 240; 4) 200,000; 5) 600; 6) Transient Protection System
- Review 7** 1) 600; 2) 1200; 3) fusible; 4) oxygen; 5) 600; 6) shunt trip; 7) a; 8) a.

# Final Exam

The final exam is intended to be a learning tool. The book may be used during the exam. A tear-out answer sheet is provided. After grading the test, mail the answer sheet in for grading. A grade of 70% or better is passing. Upon successful completion of the test a certificate will be issued. Those receiving a score of less than 70% will be provided a second test.

## Questions

1. Which of the following is not a requirement for a lighting and appliance panelboard?
  - a. A neutral connection must be provided.
  - b. A maximum of 42 overcurrent devices are allowed.
  - c. More than 10% of the overcurrent devices must be rated 30 amps or less.
  - d. Must be connected to the secondary of a 4-wire, 3-phase, wye-connected transformer.
  
2. Panelboards are covered by *NEC* article \_\_\_\_\_ .
  - a. 110
  - b. 240
  - c. 384
  - d. 430
  
3. The AIC rating of a Class R fuse is \_\_\_\_\_ amps.
  - a. 10,000
  - b. 50,000
  - c. 100,000
  - d. 200,000
  
4. The item used to cover any unused pole spaces not filled by a circuit breaker is a \_\_\_\_\_ .
  - a. deadfront
  - b. QF3 filler plate
  - c. trim
  - d. label
  
5. The type of enclosure intended for outdoor use

primarily to provide a degree of protection against rain, sleet and damage from external ice formation is \_\_\_\_\_ .

- a. Type 1
- b. Type 3R
- c. Type 4X
- d. Type 3R/12

6. The required distance in front of a panelboard door and sufficient to allow the hinged door to open 90° is \_\_\_\_\_ .

- a. 30 inches
- b. 4 feet
- c. 3 feet
- d. 6 1/2 feet

7. Two types of panelboards are \_\_\_\_\_ .

- a. main breaker and sub-feed
- b. main lug only and sub-feed
- c. main breaker and main lug only
- d. sub-feed and feed-through

8. On a three-phase, four-wire, wye-connected transformer with a secondary voltage of 480 volts phase-to-phase, the phase-to-neutral voltage is \_\_\_\_\_ volts.

- a. 277
- b. 240
- c. 138
- d. 480

9. On a three-phase, four-wire, delta-connected transformer the high leg is \_\_\_\_\_ .

- a. A - N
- b. B - N
- c. C - N
- d. A - B

10. The maximum number of switches or circuit breakers used to disconnect and isolate the service from all other equipment on service-entrance equipment is \_\_\_\_\_ .

- a. 1
- b. 2
- c. 4
- d. 6

11. The neutral conductor is \_\_\_\_\_ grounded at the service-entrance panelboard.

- a. always
- b. never
- c. rarely
- d. often

12. The neutral conductor is \_\_\_\_\_ grounded at panelboards downstream from the service-entrance panelboard.





# Notes

# Notes