

# Table of Contents

Introduction .....	2
Distribution Systems .....	4
Busway Purpose and Definition .....	6
Sentron Busway .....	10
Types and Application .....	11
Design Standards and Ratings .....	13
Circuit Protection .....	18
Busway Construction .....	26
Busway System Components .....	35
Planning a Busway System .....	50
Cable/Conduit Conversion .....	64
XL-U Busway .....	67
XJ-L Busway .....	73
BD Busway .....	76
Trol-E-Duct .....	80
Review Answers .....	86
Final Exam .....	87

# Introduction

Welcome to another course in the STEP 2000 series, **Siemens Technical Education Program**, designed to prepare our distributors to sell Siemens Energy & Automation products more effectively. This course covers **Busway** and related products.

Upon completion of **Busway** you should be able to:

- Identify the major components of several Siemens busway systems and describe their functions
- Identify the role of busway in a distribution system
- Explain the need for circuit protection
- Identify feeder and plug-in busway and explain the use of each
- Identify various organizations involved with busway design standards
- Describe selected sections of the National Electrical Code<sup>®</sup> as it applies to busway
- Measure and layout a basic busway system
- Identify various ratings of Siemens busway
- Describe how a cost savings is realized when busway is selected over cable and conduit

This knowledge will help you better understand customer applications. In addition, you will be better able to describe products to customers and determine important differences between products. You should complete **Basics of Electricity** before attempting **Busway**. An understanding of many of the concepts covered in **Basics of Electricity** is required for **Busway**.

If you are an employee of a Siemens Energy & Automation authorized distributor, fill out the final exam tear-out card and mail in the card. We will mail you a certificate of completion if you score a passing grade. Good luck with your efforts.

I-T-E, Vacu-Break, Speedfax, and XL-U are registered trademarks of Siemens Energy & Automation, Inc.

Sentron, Trol-E-Duct, BD, and XJ-L are trademarks of Siemens Energy & Automation, Inc.

National Electrical Code<sup>®</sup> and NEC<sup>®</sup> are registered trademarks of the National Fire Protection Association, Quincy, MA 02269. Portions of the National Electrical Code are reprinted with permission from NFPA 70-1996, National Electrical Code Copyright, 1995, National Fire Protection Association, Quincy, MA 02269. This reprinted material is not the complete and official position of the National Fire Protection Association on the referenced subject which is represented by the standard in its entirety.

Underwriters Laboratories, Inc. is a registered trademark of Underwriters Laboratories, Inc., Northbrook, IL 60062. The abbreviation "UL" is understood to mean Underwriters Laboratories, Inc.

National Electrical Manufacturers Association is located at 2101 L. Street, N.W., Washington, D.C. 20037. The abbreviation "NEMA" is understood to mean National Electrical Manufacturers Association.

Other trademarks are the property of their respective owners.

# Distribution Systems

A distribution system is a system that distributes electrical power throughout a building. Distribution systems are used in every residential, commercial, and industrial building.

Distribution systems used in commercial and industrial locations are complex. A distribution system consists of metering devices to measure power consumption, main and branch disconnects, protective devices, switching devices to start and stop power flow, conductors, and transformers. Power may be distributed through various switchboards, transformers, and panelboards. Good distribution systems don't just happen. Careful engineering is required so that the distribution system safely and efficiently supplies adequate electric service to both present and possible future loads.

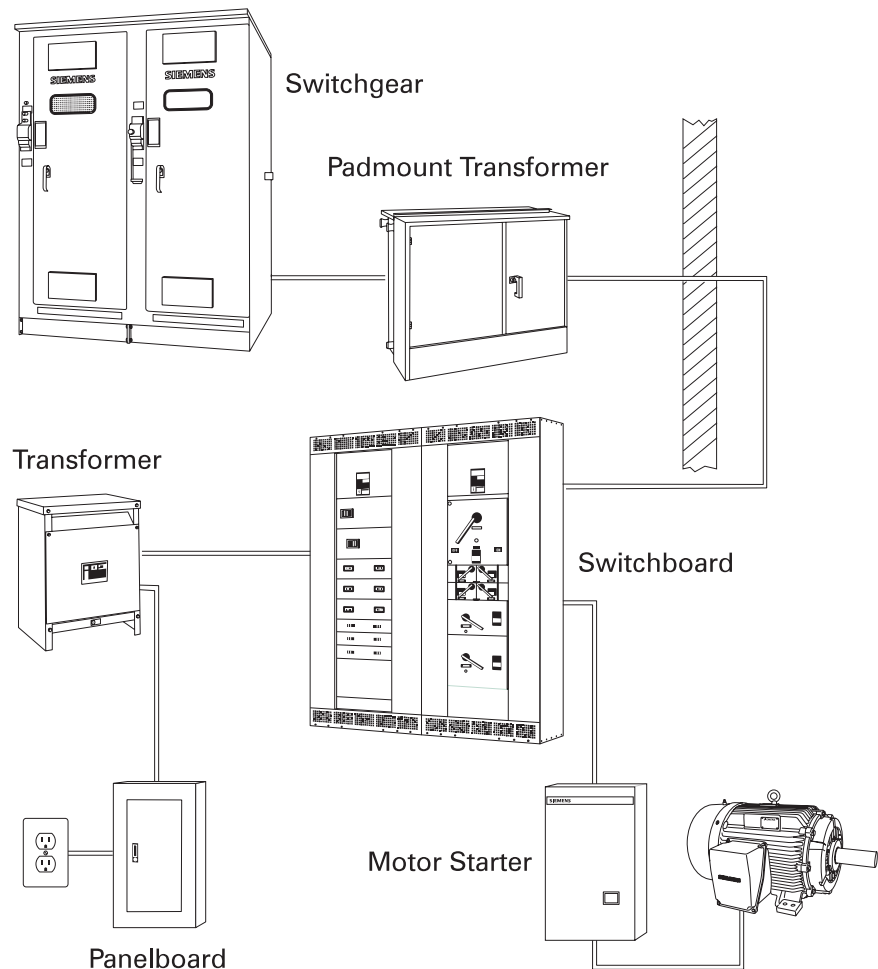

## Distribution example

In this example of a distribution system the incoming power is 277/480 volts, three-phase, four-wire. The utility company supplies power from a transformer. The secondary winding of the transformer produces 277/480 VAC.

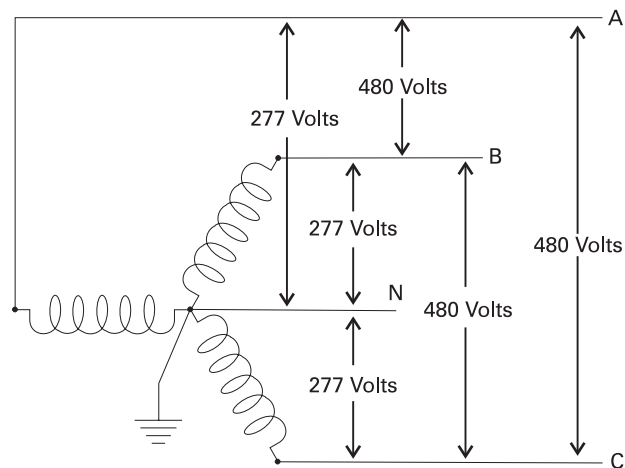

## Feeders

A feeder is a set of conductors that originate at a main distribution center and supplies one or more secondary, or one or more branch circuit distribution centers. Three feeders are used in this example. The first feeder is used for various types of power equipment. The second feeder supplies a group of 480 VAC motors. The third feeder is used for 120 volt lighting and receptacles.

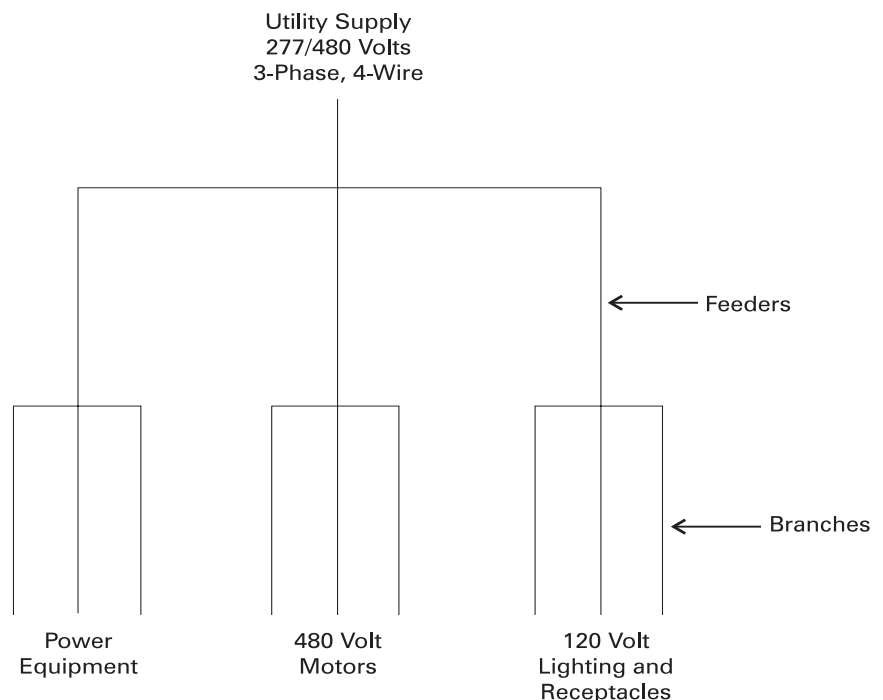

# Busway Purpose and Definition

Commercial and industrial distribution systems use several methods to transport electrical energy. These methods may include heavy conductors run in trays or conduit. Once installed, cable and conduit assemblies are difficult to change. Power may also be distributed using bus bars in an enclosure. This is referred to as busway.

## Bus bars

A bus bar is a conductor that serves as a common connection for two or more circuits. It is represented schematically by a straight line with a number of connections made to it. The National Electrical Code® article 384-3 states that bus bars *shall be located to be free from physical damage and shall be held firmly in place*. Standard bus bars in Siemens busway are made of aluminum or copper.

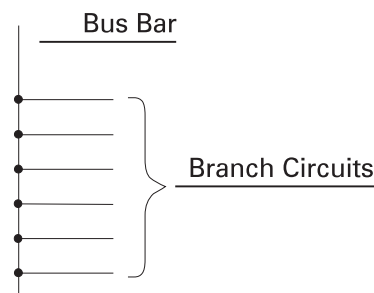

## NEMA definition

Busway is defined by the National Electrical Manufacturers Association (NEMA) as a *prefabricated electrical distribution system consisting of bus bars in a protective enclosure, including straight lengths, fittings, devices, and accessories.* Busway includes bus bars, an insulating and/or support material, and a housing.

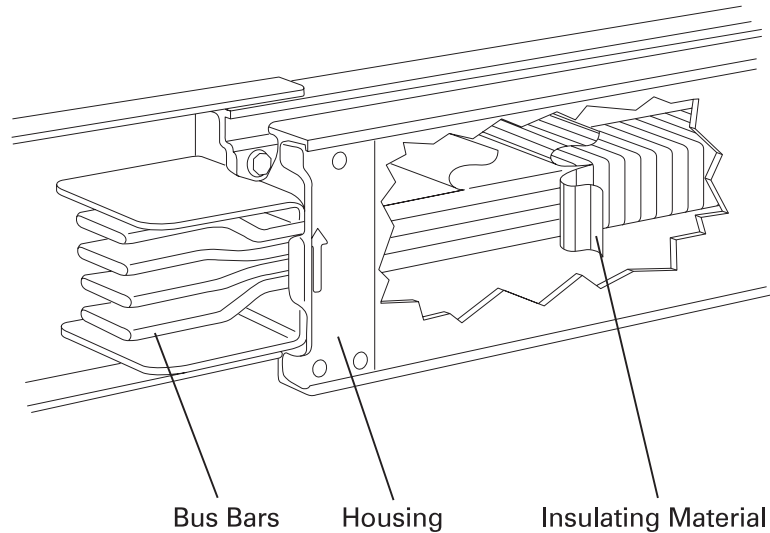

## Busway used in a distribution system

A major advantage of busway is the ease in which busway sections are connected together. Electrical power can be supplied to any area of a building by connecting standard lengths of busway. It typically takes fewer man-hours to install or change a busway system than cable and conduit assemblies.

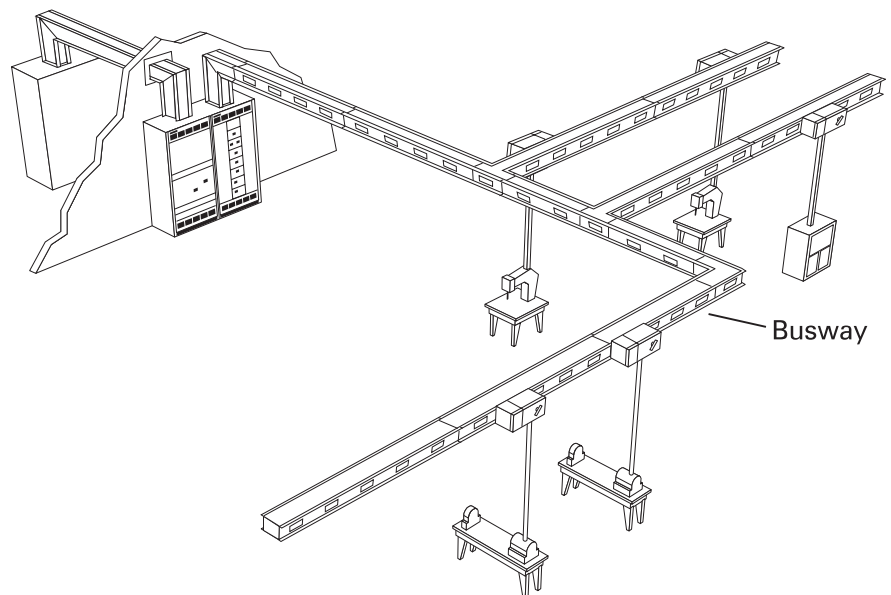

The total distribution system frequently consists of a combination of busway and cable and conduit. In this example power from the utility company is metered and enters the plant through a distribution switchboard. The switchboard serves as the main disconnecting means. The feeder on the left feeds a distribution switchboard, which in turn feeds a panelboard and a 480 volt, three-phase, three-wire (3Ø3W) motor. The middle feeder feeds another switchboard, which divides the power into three, three-phase, three-wire circuits. Each circuit feeds a busway run to 480 volt motors. The feeder on the right supplies 120/208 volt power, through a step-down transformer, to lighting and receptacle panelboards. Branch circuits from the lighting and receptacle panelboards supply power for lighting and outlets throughout the plant. In many cases busway can be used in lieu of the cable/conduit feeders at a lower cost.

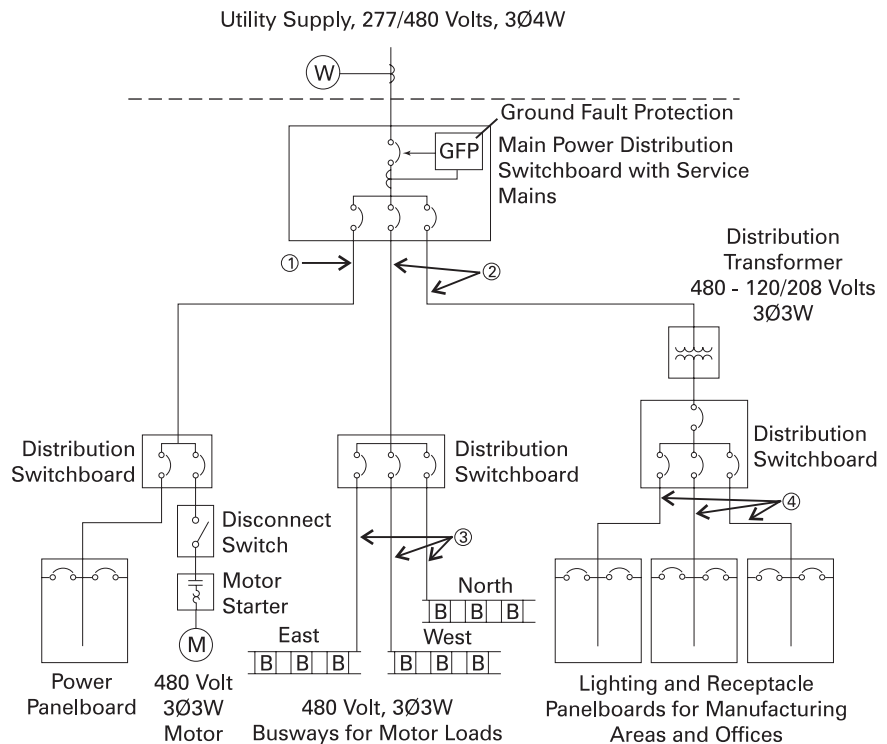

Symbols			
	Circuit Breaker		Transformer
	Switch		Current Transformer
	Motor		Busway
	Motor Starter		Watt Hour Meter

- ① 277/480 Volt 3Ø4W Feeder
- ② 480 Volt 3Ø3W Feeders
- ③ 480 Volt 3Ø3W Circuits
- ④ 120/208 Volt 3Ø4W Circuits

Busway is used in various applications and can be found in industrial installations as well as high-rise buildings. Busway used in industrial locations can supply power to heavy equipment, lighting, and air conditioning. Busway risers (vertical busway) can be installed economically in a high-rise building where it can be used to distribute lighting and air conditioning loads.

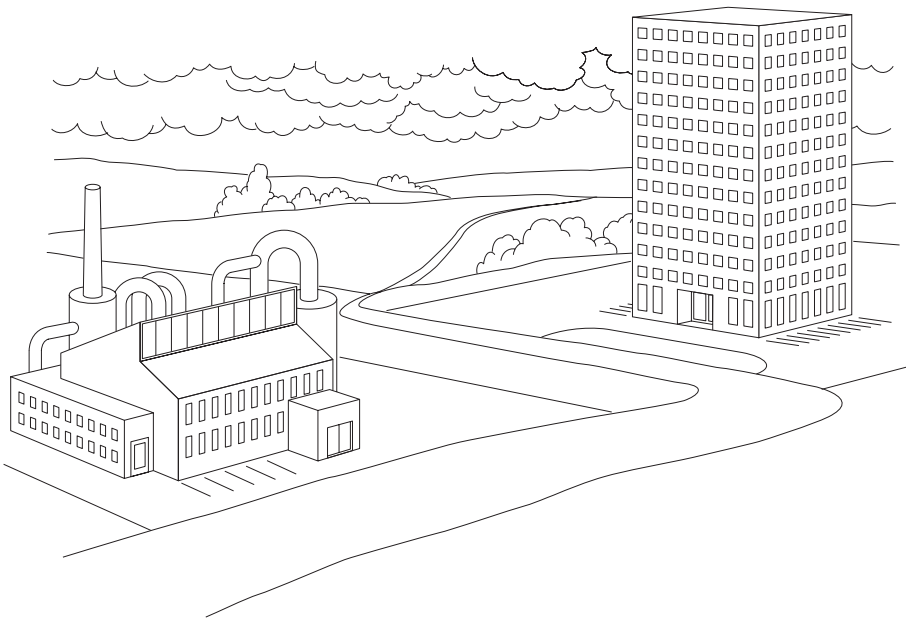

# Sentron Busway

Throughout this course Siemens Sentron™ busway will be used to explain and illustrate principles and requirements of busway. Sentron busway will meet the needs of most busway systems with current ratings from 225 amperes to 5000 amperes. Siemens manufactures several types of busway. There are a number of reasons why different types of busway are manufactured. An existing pre-Sentron busway system, for example, may need to be expanded. Other types of Siemens busway, including significant features, and ratings will be discussed later in the course.

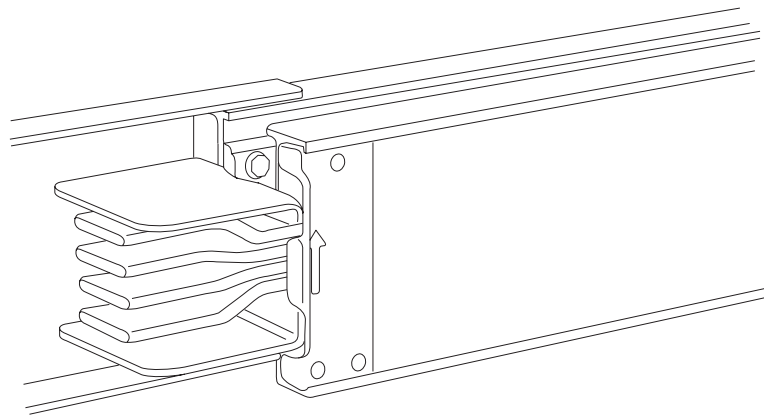

Sentron Busway

# Types and Application

## Feeder busway

There are two types of busway: feeder and plug-in. Feeder busway is used to distribute power to loads that are concentrated in one physical area. Industrial applications frequently involve long runs from the power source to a single load. This load may be a large machine, motor control center, panelboard, or switchboard.

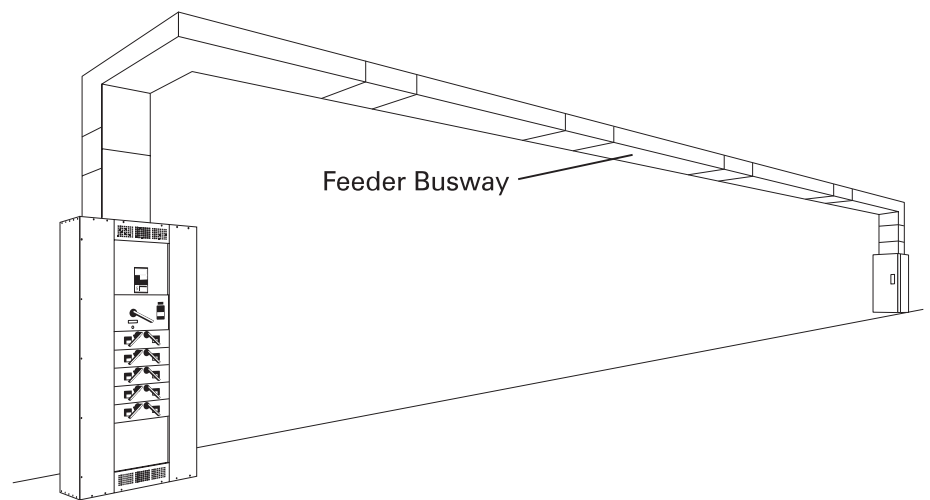

## Service entrance

The service entrance is the point of entrance of supply conductors to a building or other structure. Feeder busway, which can be purchased for indoor or outdoor use, can be used as service entrance conductors to bring power from a utility transformer to a main disconnect inside the building.

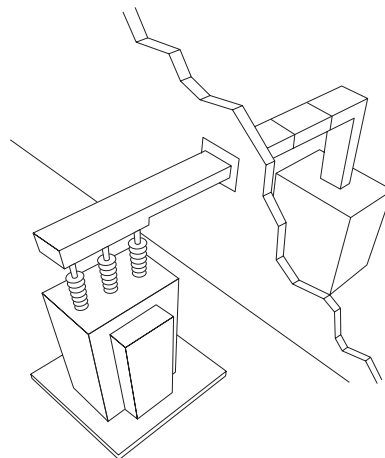

## Plug-in busway

Plug-in busway is used in applications where power requirements are distributed over a large area. Using plug-in units, load connections can be added or relocated easily. Plug-in busway is for indoor use only.

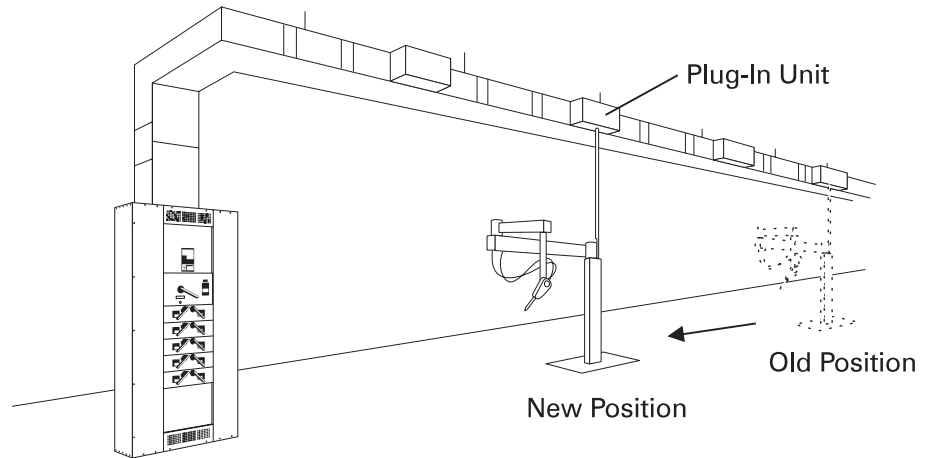

## Review 1

1. A \_\_\_\_\_ distributes electrical power throughout a building.
2. A \_\_\_\_\_ is a set of conductors that originate at a main distribution center and supply one or more secondary, or one or more branch circuit distribution centers.
3. \_\_\_\_\_ is a type of power distribution device that is made up of heavy bus bars in an enclosure.
4. It typically takes fewer man-hours to install or change a \_\_\_\_\_ system than cable and conduit assemblies.
5. The two types of busway are \_\_\_\_\_ and \_\_\_\_\_.
6. \_\_\_\_\_ busway can be purchased for use indoors or outdoors, \_\_\_\_\_ busway is for indoor use only.

# Design Standards and Ratings

Several organizations maintain standards of design, construction, installation, and performance of busway. The following list includes some of these organizations:

- Underwriters Laboratories, Inc. (UL)
- The National Electrical Manufacturers Association (NEMA)
- International Electrotechnical Commission (IEC)
- The National Electrical Code*<sup>®</sup> (*NEC*<sup>®</sup>)
- Organizations responsible for state and local electrical codes

Sentron™ busway meets the worldwide standards of UL 857, IEC 439-1, and IEC 439-2.

## Underwriters Laboratories

Busway bearing the Underwriters Laboratories listing mark must pass a series of performance tests based on UL publication UL 857. These tests and standards relate to the strength and integrity of a busway system when subjected to specific operating and environmental conditions.

UL 1479 provides guidelines for a fire rating. Sentron busway has been tested in accordance with UL 1479 and offers a certified two hour fire rating for gypsum wallboard and a three hour fire rating for concrete slab or cement block. These ratings are achieved by using standard Sentron busway installed with SpecSeal<sup>®</sup> sealant from Specified Technologies, Inc.

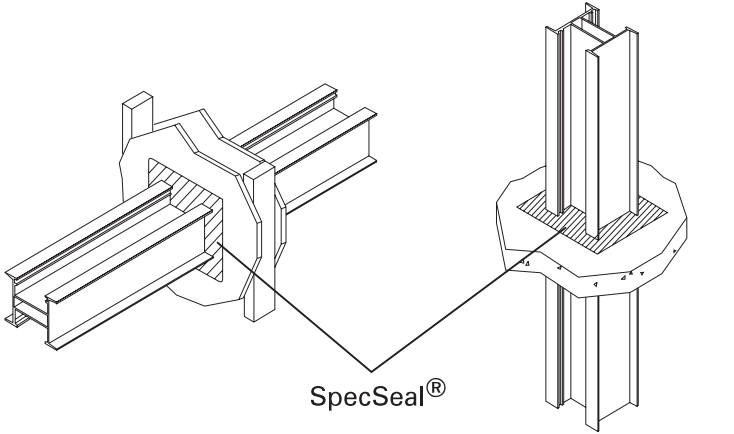

Two Hour Fire Rating  
Gypsum Wallboard

Three Hour Fire Rating  
Concrete Slab

## NEMA

NEMA standards for busway are listed in NEMA publication number BU 1-1995. NEMA is primarily associated with equipment used in North America. It is important to note that NEMA short-circuit ratings require a 3 cycle short-circuit rating. This means that the busway was tested and rated on the basis of successfully experiencing 3 cycles of peak current (IP). NEMA recommends the following minimum short-circuit current ratings for busway.

Continuous Current Rating of Busway (Amperes)	Short-Circuit Ratings (Symmetrical Amperes)	
	Plug-In Busway	Feeder Busway
100	10,000	—
225	14,000	—
400	22,000	—
600	22,000	42,000
800	22,000	42,000
1000	42,000	75,000
1200	42,000	75,000
1350	42,000	75,000
1600	65,000	100,000
2000	65,000	100,000
2500	65,000	150,000
3000	85,000	150,000
4000	85,000	200,000
5000	—	200,000

## IEC

The International Electrotechnical Commission is associated with equipment sold in many countries, including the United States. IEC standards are found in IEC publications 439 and 529.

IEC also recommends short-circuit ratings for busway. Siemens manufacturers Sentron busway with continuous current ratings from 225 amperes to 5000 amperes. The following table shows the short-circuit ratings for Sentron busway. These ratings meet IEC specifications.

Continuous Current Rating of Sentron Busway (Amperes)	6 Cycle (0.1 sec.) Short-Circuit Ratings (Symmetrical Amperes)		60 Cycle (1 sec.) Short-Circuit Ratings (Symmetrical Amperes)	
	Aluminum	Copper	Aluminum	Copper
225	85,000	85,000	28,000	40,000
400				
600				
800	100,000	100,000	47,000	40,000
1000			50,000	50,000
1200	125,000	100,000	60,000	65,000
1350	150,000		75,000	80,000
1600		125,000	90,000	95,000
2000		150,000	110,000	115,000
2500	200,000	150,000	130,000	130,000
3000		200,000	160,000	175,000
4000			200,000	200,000
5000	—	—	—	

The following chart lists IEC specifications for enclosure protection of busway.

IEC 529 - Degrees of Protection Provided by Enclosures		Approved for Sentron Busway		
Code	Description	Feeder	Plug-In	Plug-In Units
<b>IP 2X</b>	Plug-in outlet protects against access to live parts by 12 mm (.472") test probe, even with cover opened. <u>Finger Safe</u> .	✓	✓	✓
<b>IP 40</b>	Enclosure protects against entry of 1.0 mm (.039") test probe. <u>Indoor</u> (Typical UL designation).	✓	✓	✓
<b>IP 43</b>	Enclosure protects against entry of 1.0 mm (.039") test probe and dripping water. <u>Drip Proof</u> .	✓	✓	✓
<b>IP 54</b>	Enclosure protects against entry of dust and splashing water. <u>Spray Proof</u> .	✓	✓	✓
<b>IP 65</b>	Enclosure is dust tight and protects against water jets. <u>Outdoor</u> (Typical UL designation).	✓		
<b>IP 66</b>	Enclosure is dust tight and protects against powerful water jets. <u>Severe Outdoor</u> .	✓		

#### Feeder or Plug-In

Indoor	IP 40
Drip Proof	IP 43
Spray Proof	IP 54

#### Feeder Only

Outdoor	IP 65
Severe Outdoor	IP 66

## **National Electrical Code**

The *National Electrical Code*<sup>®</sup> (sponsored by the National Fire Protection Association), once adopted by the authority having jurisdiction, stipulates installation requirements which are necessary for the safe application of electrical equipment. Article 364 of the *NEC*<sup>®</sup> specifically applies to busway, although other articles in the *NEC*<sup>®</sup> are applicable in certain situations. Thorough familiarization of the *NEC*<sup>®</sup> requirements for busway is recommended.

- 364-1 Scope
- 364-2 Definition
- 364-3 Other Articles
- 364-4 Use
- 364-5 Support
- 364-6 Through Walls and Floors
- 364-7 Dead Ends
- 364-8 Branches from Busways
- 364-9 Overcurrent Protection
- 364-10 Rating of Overcurrent Protection - Feeders
- 364-11 Reduction in Ampacity Size of Busway
- 364-12 Feeder of Branch Circuits
- 364-13 Rating of Overcurrent Protection - Branch Circuits
- 364-15 Marking

## **State and local codes**

State and local authorities have electrical codes which are often more stringent than other organizations. You are encouraged to become familiar with this material in your local area. In addition, busway is frequently used for the main electrical service of a building, in which case the busway is connected to one or more distribution transformers owned by local electric power companies. Electrical power companies throughout the United States prefer different methods of connecting to busway. It is recommended that the local power company be contacted before applying or installing a service entrance busway run.

# Circuit Protection

Circuit protection must be taken into consideration with any electrical circuit, including busway. Current flow in a conductor always generates a watts loss in the form of heat. As current flow increases, the conductor must be sized appropriately in order to compensate for higher watt losses. Excess heat is damaging to electrical components. For that reason, conductors have a rated continuous current carrying capacity or ampacity. Overcurrent protection devices are used to protect conductors from excessive current flow. Two devices used to protect circuits from overcurrent are fuses and circuit breakers. These protective devices are designed to limit the flow of current in a circuit to a safe level, preventing the circuit conductors from overheating.

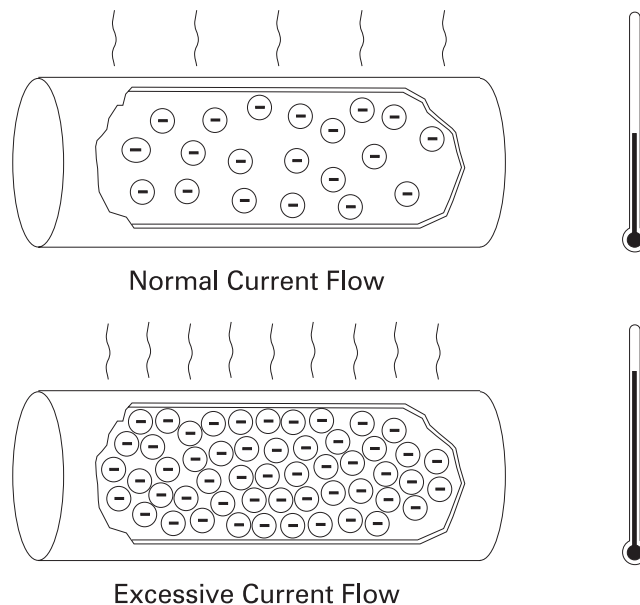

The *National Electrical Code*<sup>®</sup> defines overcurrent as *any current in excess of the rated current of equipment or the ampacity of a conductor. It may result from overload, short circuit, or ground fault* (Article 100-definitions).

Circuit protection would be unnecessary if overloads and short circuits could be eliminated. Unfortunately, overloads and short circuits do occur. To protect a circuit against these currents, a protective device must determine when a fault condition develops and automatically disconnect the electrical equipment from the voltage source.

**Inverse time-current characteristic**

An overcurrent protection device must be able to recognize the difference between overcurrents and short circuits and respond in the proper way. Protection devices use an inverse time-current characteristic. Slight overcurrents can be allowed to continue for some period of time, but as the current magnitude increases, the protection device must open faster. Short circuits must be interrupted instantly.

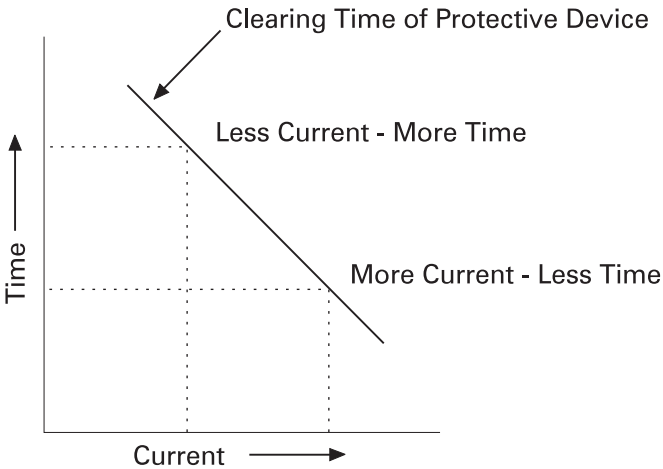

**Fuse construction**

A fuse is the simplest device for interrupting a circuit experiencing an overload or a short circuit. A typical fuse, like the one shown below, consists of an element electrically connected to end blades or ferrules. The element provides a current path through the fuse. The element is enclosed in a tube and surrounded by a filler material.

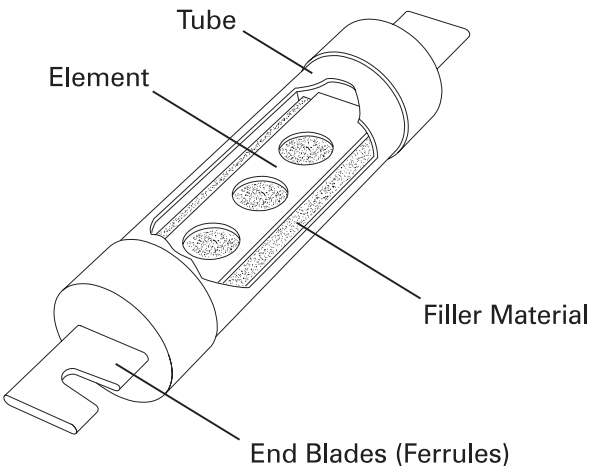

### **Fuse subject to overcurrent**

Current flowing through the element generates heat, which is absorbed by the filler material. When an overcurrent occurs temperature in the element rises. In the event of a harmless transient overload condition the excess heat is absorbed by the filler material. If a sustained overload occurs the heat will eventually melt open an element segment forming a gap; thus stopping the flow of current.

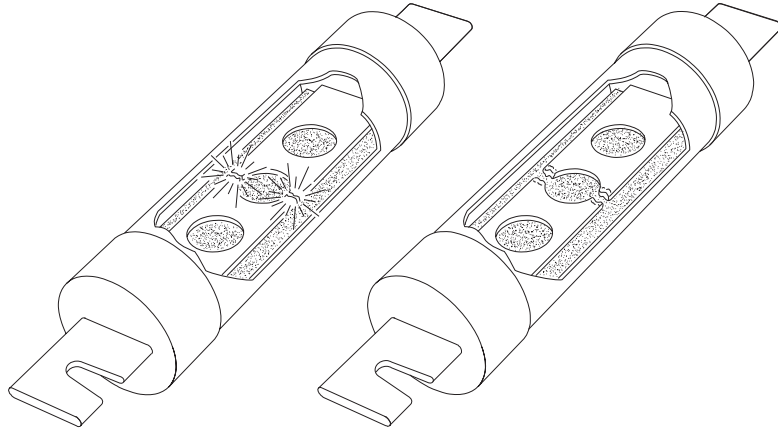

### **Short-circuit current**

Short-circuit current can be several thousand amperes and generates extreme heat. When a short circuit occurs several element segments can melt simultaneously, which helps remove the load from the source voltage quickly. Short-circuit current is typically cut off in less than half a cycle, before it can reach its full value.

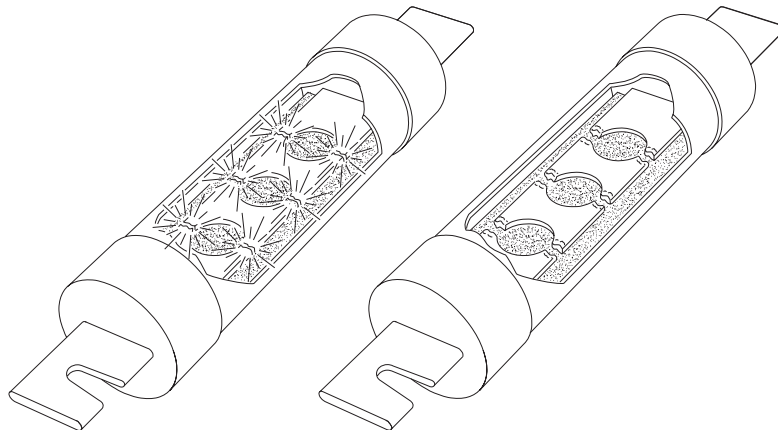

**Nontime-delay fuses**

Nontime-delay fuses provide excellent short circuit protection. Short-term overloads, such as motor starting current, may cause nuisance openings of nontime-delay fuses. They are best used in circuits not subject to large transient surge currents. Nontime-delay fuses usually hold 500% of their rating for approximately one-fourth second, after which the current carrying element melts. This means that these fuses should not be used in motor circuits which often have inrush (starting) currents greater than 500%.

**Time-delay fuses**

Time-delay fuses provide overload and short circuit protection. Time-delay fuses usually allow five times the rated current for up to ten seconds. This is normally sufficient time to allow a motor to start without nuisance opening of the fuse unless an overload persists.

**Ampere rating**

Fuses have a specific ampere rating, which is the continuous current carrying capability of a fuse. The ampere rating of a fuse, in general, should not exceed the current carrying capacity of the circuit. For example, if a conductor is rated for 10 amperes, the largest fuse that would be selected is 10 amperes.

There are some specific circumstances when the ampere rating is permitted to be greater than the current carrying capacity of the circuit. For example, motor and welder circuits can exceed conductor ampacity to allow for inrush currents and duty cycles within limits established by the *NEC*<sup>®</sup>.

**Sentron fusible switches**

Plug-in fusible switches are available on Siemens busway. Sentron™ fusible switches, for example, are rated from 30 - 600 amperes.

**Voltage rating**

The voltage rating of a fuse must be at least equal to the circuit voltage. The voltage rating of a fuse can be higher than the circuit voltage, but never lower. A 600 volt fuse, for example, can be used in a 480 volt circuit. A 250 volt fuse could not be used in a 480 volt circuit.

**Ampere interrupting capacity (AIC)**

Fuses are also rated according to the level of fault current they can interrupt. This is referred to as ampere interrupting capacity (AIC). When applying a fuse, one must be selected which can sustain the largest potential short circuit current which can occur in the selected application. The fuse could rupture, causing extensive damage, if the fault current exceeds the fuse interrupting rating.

## UL fuse classification

Fuses are grouped into current limiting and non-current limiting classes based on their operating and construction characteristics. Fuses that incorporate features or dimensions for the rejection of another fuse of the same ampere rating but with a lower interruption rating are considered current limiting fuses. Underwriters Laboratories (UL) establishes and standardizes basic performance and physical specifications to develop its safety test procedures. These standards have resulted in distinct classes of low voltage fuses rated at 600 volts or less. The following chart lists various UL fuse classes.

Class	Voltage Rating	Ampere Rating	Interrupting Rating (Amperes)	Sub Classes	UL Standard
G*	300	0-60	100,000		UL 198 C
H	250, 600	0-600	10,000	Renewable Nonrenewable	UL 198 B
J*	600	0-600	200,000		UL 248 B
K	250, 600	0-600	50,000, or 100,000, or 200,000	K1 and K5	UL 198 D
L*	600	601-6000	200,000		UL 248 10
R*	250, 600	0-600	200,000	RK1 and RK5	UL 248 12
T*	300	0-1200	200,000		UL 248 15
T*	600	0-800	200,000		UL 248 15
CC*	600	0-30	200,000		UL 248 4
Plug	125	0-30	10,000	"Edison Base" and Type S	UL 198 F

\* Current Limiting Fuses

## Circuit breakers

Another device used for overcurrent protection is a circuit breaker. The *National Electrical Code*® defines a circuit breaker as *a device designed to open and close a circuit by nonautomatic means, and to open the circuit automatically on a predetermined overcurrent without damage to itself when properly applied within its rating* (Article 100 - definitions).

Circuit breakers provide a manual means of energizing and deenergizing a circuit. In addition, circuit breakers provide automatic overcurrent protection of a circuit. A circuit breaker allows a circuit to be reactivated quickly after a short circuit or overload is cleared. Unlike fuses which must be replaced when they open, a simple flip of the breaker's handle restores the circuit.

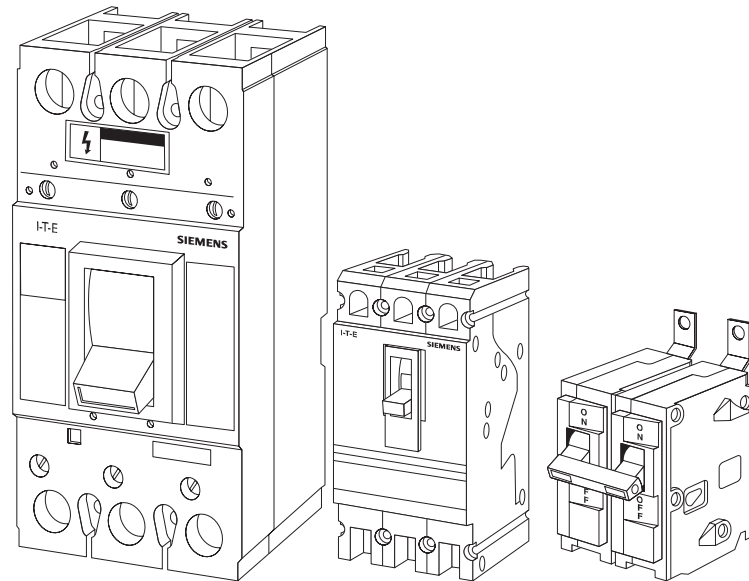

## Ampere rating

Like fuses, every circuit breaker has a specific ampere, voltage, and fault current interruption rating. The ampere rating is the maximum continuous current a circuit breaker can carry without exceeding its rating. As a general rule, the circuit breaker ampere rating should match the conductor ampere rating. For example, if the conductor is rated for 20 amperes, the circuit breaker should be rated for 20 amperes. Siemens I-T-E® breakers are rated on the basis of using 60° C or 75° C conductors. This means that even if a conductor with a higher temperature rating were used, the ampacity of the conductor must be figured on its 60° C or 75° C rating.

There are some specific circumstances when the ampere rating is permitted to be greater than the current carrying capacity of the circuit. For example, motor and welder circuits can exceed conductor ampacity to allow for inrush currents and duty cycles within limits established by *NEC*<sup>®</sup>. Generally the ampere rating of a circuit breaker is selected at 125% of the continuous load current. This usually corresponds to the conductor ampacity which is also selected at 125% of continuous load current. For example, a 125 ampere circuit breaker would be selected for a load of 100 amperes.

### **Sentron MCCB plug-in units**

Plug-in devices with molded case circuit breakers (MCCB) are available on Sentron busway with circuit breaker ratings from 125 - 800 amperes.

### **Voltage rating**

The voltage rating of the circuit breaker must be at least equal to the circuit voltage. The voltage rating of a circuit breaker can be higher than the circuit voltage, but never lower. For example, a 480 VAC circuit breaker could be used on a 240 VAC circuit. A 240 VAC circuit breaker could not be used on a 480 VAC circuit. The voltage rating is a function of the circuit breaker's ability to suppress the internal arc that occurs when the circuit breaker's contacts open.

### **Fault current interrupting rating**

Circuit breakers are also rated according to the level of fault current they can interrupt. When applying a circuit breaker, one must be selected which can sustain the largest potential short circuit current which can occur in the selected application. Siemens circuit breakers have interrupting ratings from 10,000 to 200,000 amperes. To find the interrupting rating of a specific circuit breaker refer to the Speedfax<sup>®</sup> catalog.

### **Additional information**

For additional information on circuit breakers refer to the STEP 2000 course, **Molded Case Circuit Breakers**.

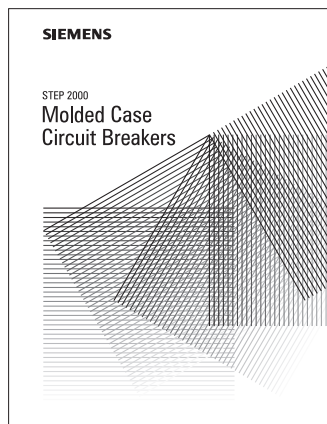

## Review 2

1. In accordance with UL 1479, Sentron busway offers a \_\_\_\_\_ hour fire rating for gypsum wallboard, and a \_\_\_\_\_ hour fire rating for concrete slab when used with SpecSeal<sup>®</sup> sealant.
2. Sentron busway, with a continuous current rating of 800 amperes and aluminum bus bars, has a 60 cycle short-circuit rating of \_\_\_\_\_ amperes.
3. The highest level of enclosure protection of Sentron feeder busway is IP \_\_\_\_\_ and the highest level of enclosure protection of Sentron plug-in busway is IP \_\_\_\_\_ .
4. Article \_\_\_\_\_ in the *National Electrical Code*<sup>®</sup> specifically applies to busway.
5. A Class R has an ampere interrupting capacity of \_\_\_\_\_ amperes.
6. Siemens circuit breakers have a fault current interrupting capacity of \_\_\_\_\_ to \_\_\_\_\_ amperes.

# Busway Construction

## Bus bars

A better understanding of what busway is can be gained by examining its construction. A typical Siemens Sentron™ busway section has three or four formed aluminum or copper bars that function as electrical conductors. Aluminum bars are standard and can be supplied in ampacities up to 4000 amperes. Copper bars are optional and can be supplied in ampacities up to 5000 amperes.

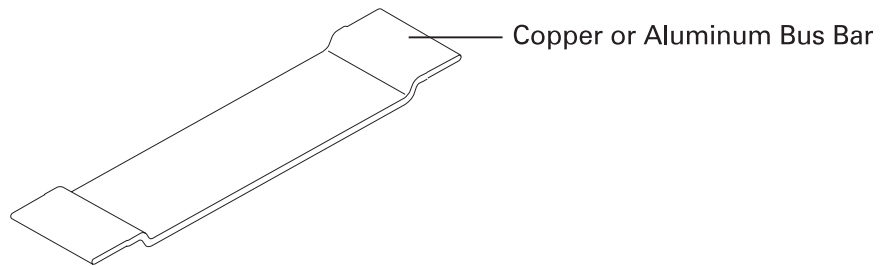

Bus bars manufactured for use in feeder busway differ from those manufactured for use in plug-in busway. Plug-in busway will have a tab or some other form of connecting a plug-in device such as a disconnect.

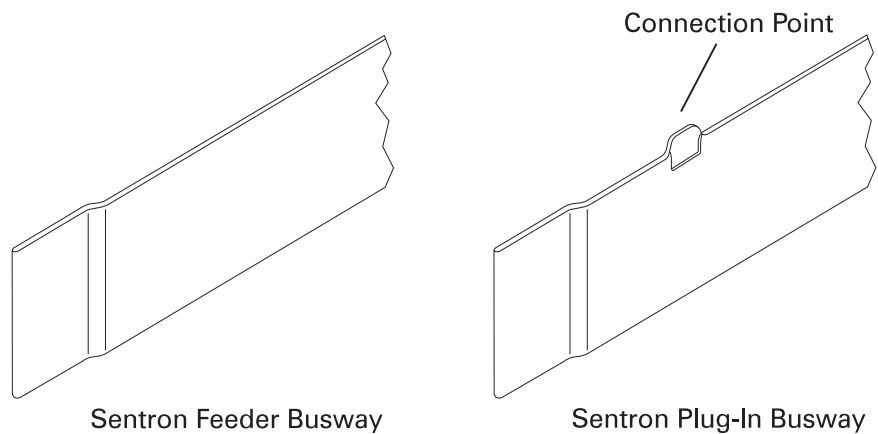

Each bus bar is referred to as a phase. Bus bars of Sentron busway are separately insulated with epoxy.

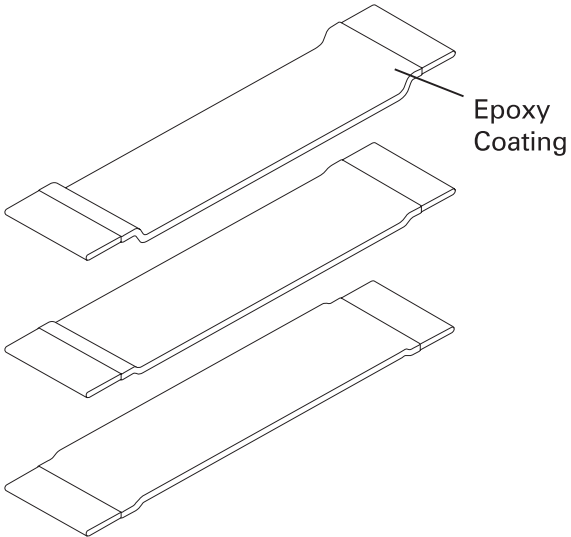

**Enclosure**

Insulation is wrapped around the Sentron bus bars to provide additionally protection and hold the bars together. The bus bars are then installed in an enclosure. The enclosure provides protection and support.

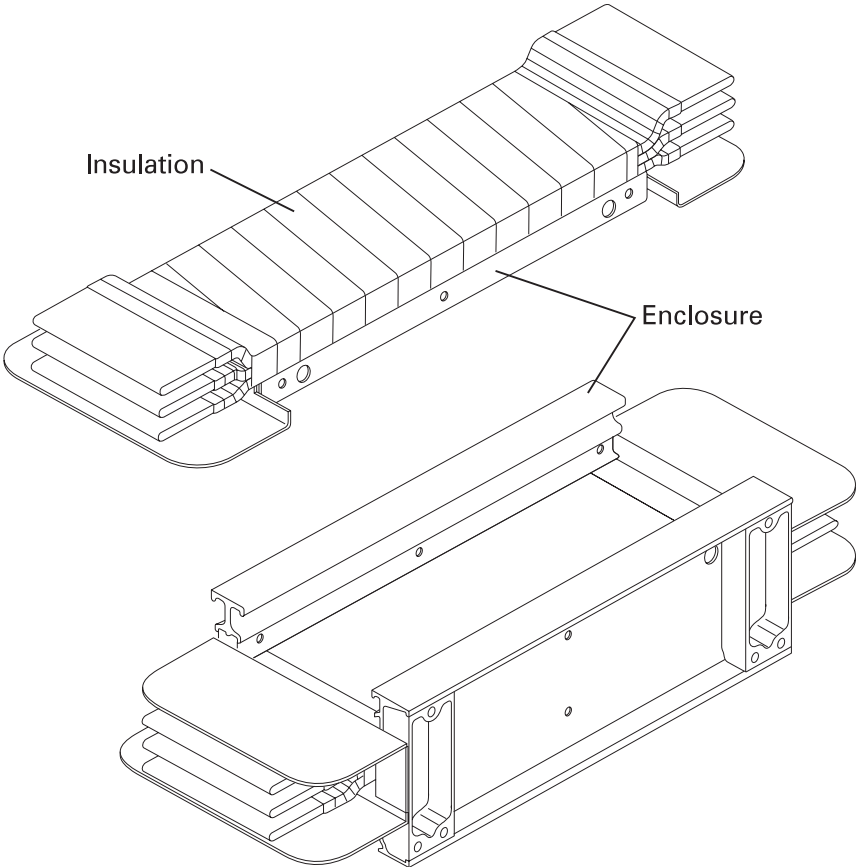

## Bars per pole

Sentron busway uses one bar per pole on busway rated up to 2000 amperes aluminum and 2500 amperes copper.

One Bar Per Pole

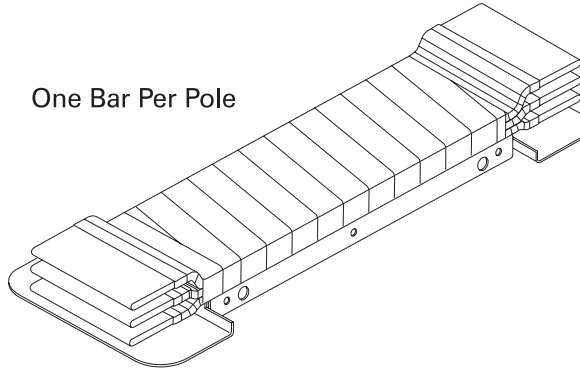

Aluminum		Copper	
Ampere Rating	Ampere Rating	Ampere Rating	Ampere Rating
225	1200	225	1200
400	1350	400	1350
600	1600	600	1600
800	2000	800	2000
1000	—	1000	2500

Sentron busway uses two bars per pole on busway rated from 2500 to 4000 amperes aluminum and 3000 to 5000 amperes copper.

Two Bars Per Pole

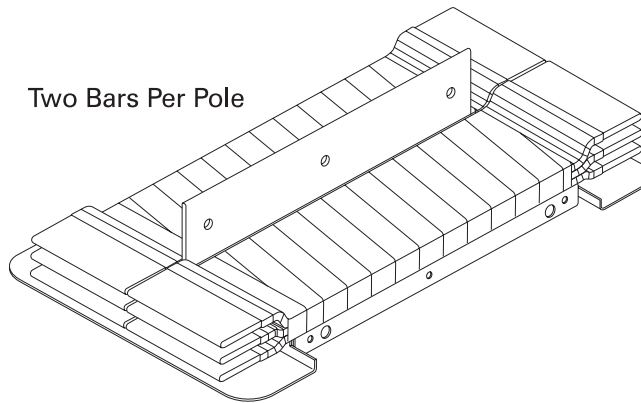

Aluminum	Copper
Ampere Rating	Ampere Rating
2500	3000
3000	4000
4000	5000

## NEMA phase arrangement

Bus bars are required to have phases in sequence so that an installer can have the same fixed phase arrangement in each termination point. This is established by NEMA (National Electrical Manufacturers Association). The following diagram illustrates accepted NEMA phase arrangements.

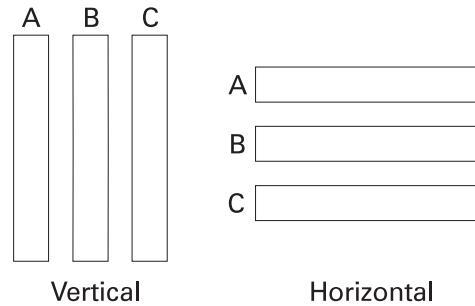

The following illustration shows the proper phase arrangement of bus bars in Sentron busway.

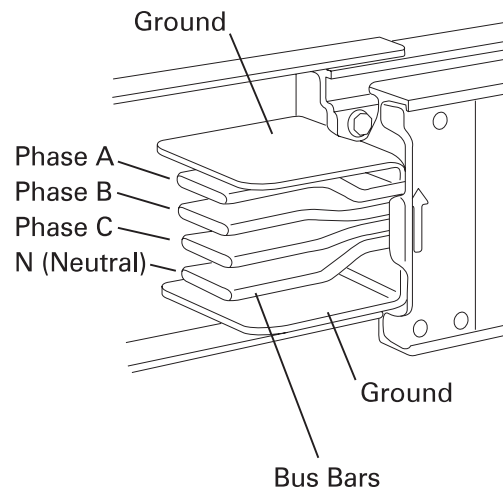

## Number of bus bars

The number of bars depends on the number of phases on the power supply and whether or not a neutral or ground is used.

3 Phase, 3 Wire,

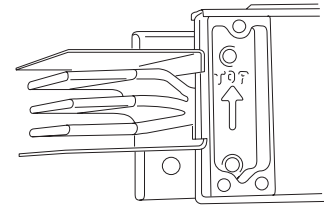

3 Phase, 4 Wire (Neutral)

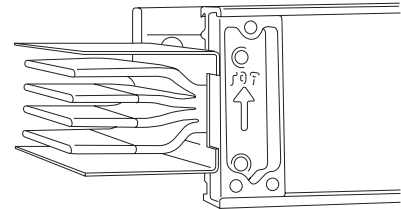

## 200% neutral

Siemens Sentron busway is available with a 200% neutral within the bus bar housing. Certain loads on the distribution system can cause non-sinusoidal current referred to as harmonics. These harmonics cause circulating currents which increase the heat in the system and shorten component life. The 200% neutral capacity minimizes overheating, thus prolonging the life of power distribution equipment.

3 Phase, 4 Wire, 100% Neutral

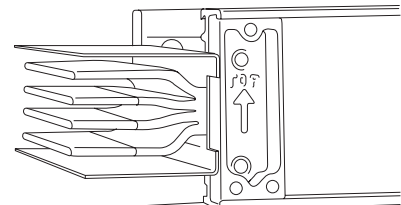

3 Phase, 4 Wire, 200% Neutral

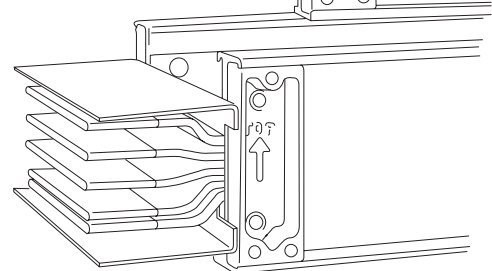

## Ground

The *National Electrical Code*® requires the metal enclosure of any busway run to be grounded back at the service entrance equipment. Sentron busway has several options to meet this requirement. The busway housing is an integral ground. Under more severe industrial applications a heavier ground may be required. The following cross section drawing of Sentron busway shows a bus bar a 50% internal ground has been added. This means that the ground is rated at 50% of the ampacity of the phase bus bars.

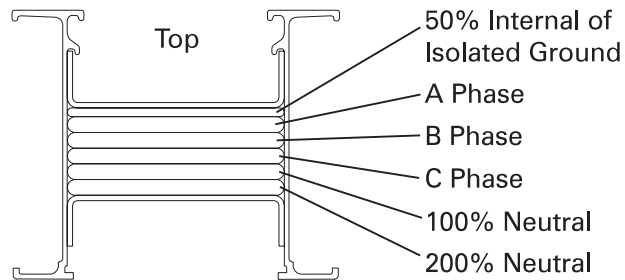

## Busway lengths

The standard length of a plug-in busway section is 10'. Sentron busway is also available in 4', 6', and 8' lengths.

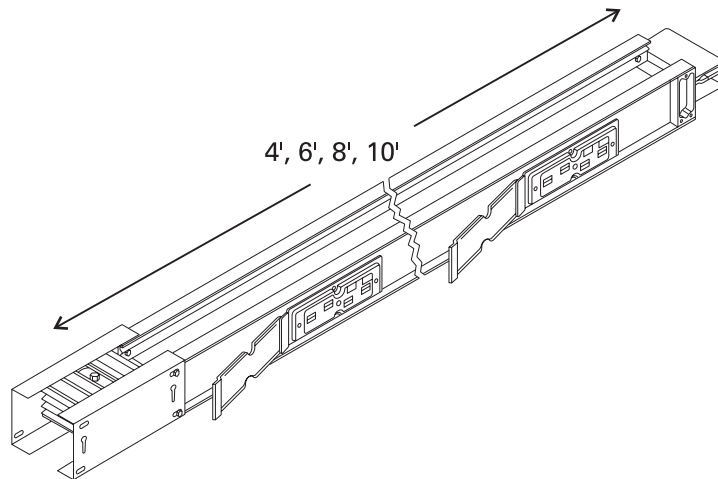

Plug-in outlets on Sentron plug-in busway are located on 2' centers on both sides of the busway.

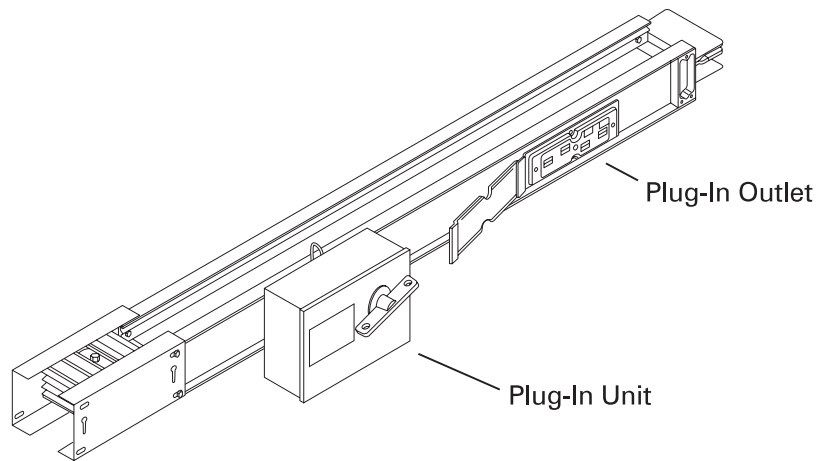

### Sentron plug-in outlets

The Sentron plug-in outlet features a molded guard which prevents incidental finger contact with live conductors. This meets IEC, IP 2X requirements for preventing a 12 mm (.472") probe from entering. This is referred to as finger safe.

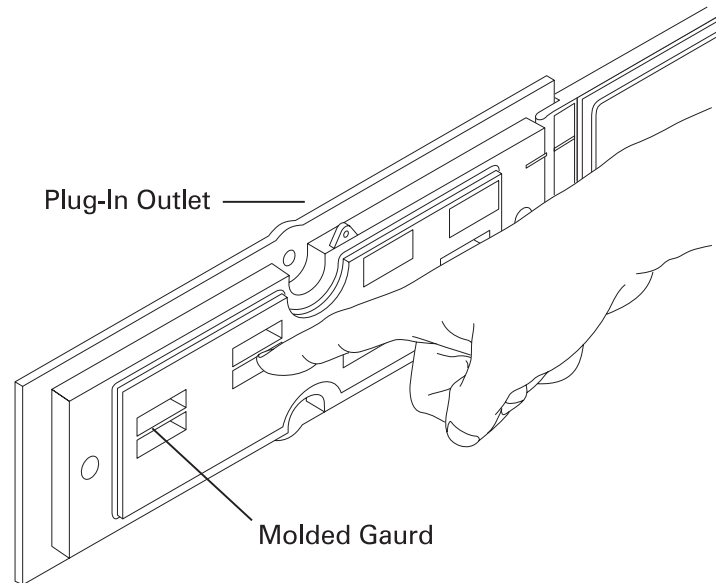

## Feeder busway lengths

In addition to the 4', 6', 8', and standard 10' lengths, Sentron feeder busway sections are available in 0.125" increments from 2' to 10'. Feeder busway does not have any plug-in outlets.

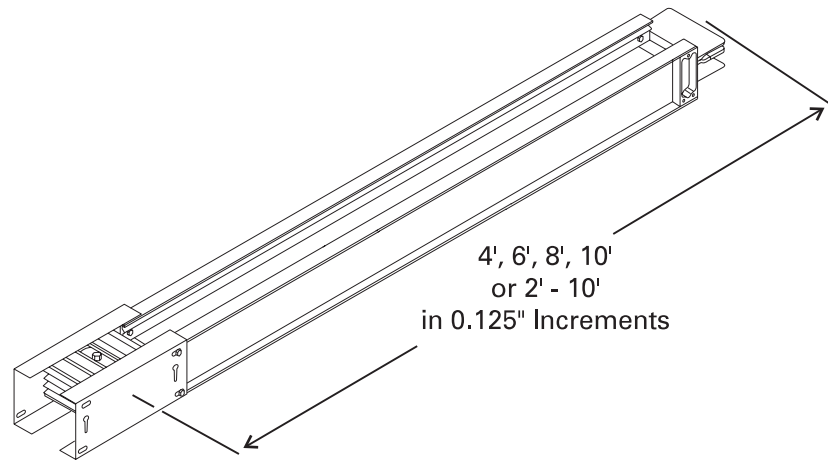

### Review 3

1. In the Sentron busway, aluminum bus bars are available with ampacities up to \_\_\_\_\_ amperes and copper bus bars are available with ampacities up to \_\_\_\_\_ amperes.
2. Identify the type of busway each of the bus bars represent in the following illustration.

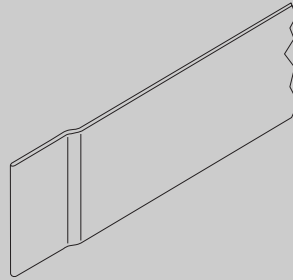

a. \_\_\_\_\_

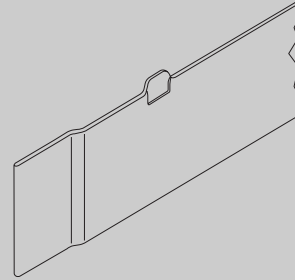

b. \_\_\_\_\_

3. Plug-in busway is available in \_\_\_\_\_ , \_\_\_\_\_ , \_\_\_\_\_ , and 10 foot lengths.
4. Plug-in outlets are located on \_\_\_\_\_ foot centers.
5. Sentron feeder busway sections are available in \_\_\_\_\_ inch increments from \_\_\_\_\_ to \_\_\_\_\_ feet.

# Busway System Components

There are a number of components that make up a busway system. The various system components illustrated in this section, unless otherwise noted, will be the Siemens Sentron™ series. For more information on any component consult the *Sentron Busway System Selection and Application Guide*. It should also be noted that certain components available on one type busway system may not be available on another type busway system.

Although components used in various busway systems perform the same or similar functions, they can't be interchanged from one busway system to another. There are a number of reasons for this. Systems are tested and rated as a complete unit. Ratings and system integrity could not be guaranteed when components are interchanged between systems. Additionally, components from one system may not physically fit or connect to components of another system. Sections of Siemens Sentron busway, for example are clamped together with a joint stack. Siemens BD™ busway is bolted together.

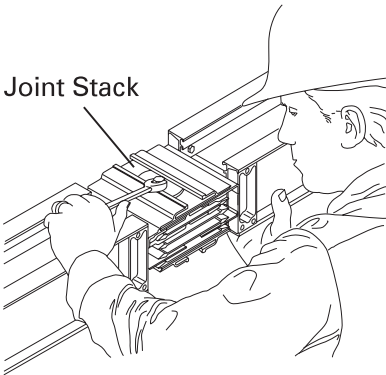

Sentron Busway

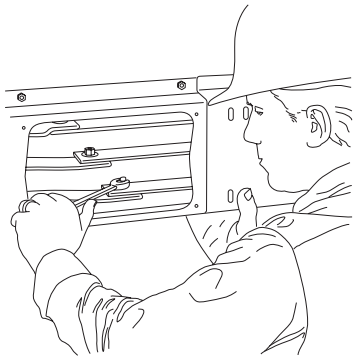

BD Busway

## Joint stack

The Siemens Sentron busway system, uses a single-bolt joint stack to connect busway sections. The bus bars from two busway sections are slid into a joint stack.

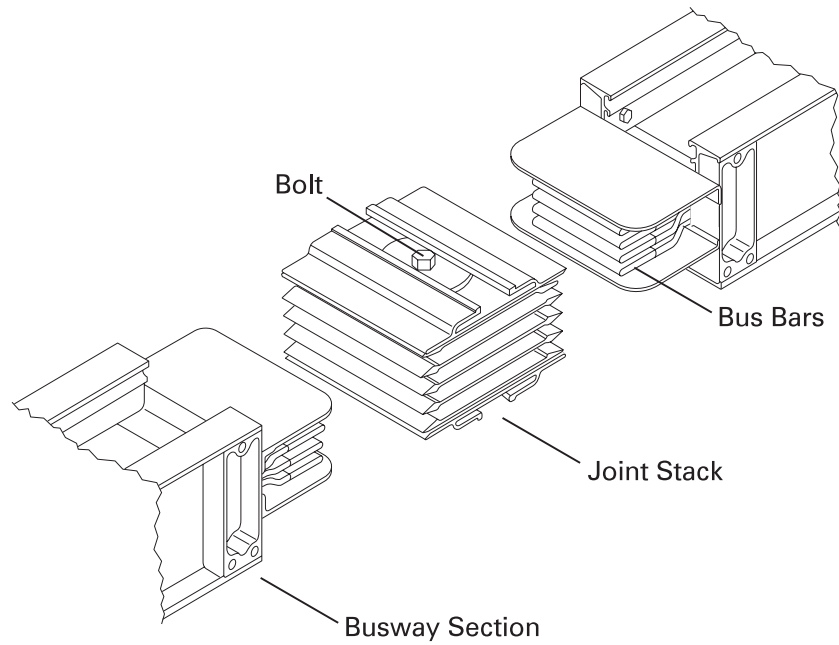

The assembly is clamped solidly together with the single bolt located on the joint stack. Sentron busway sections and components are supplied with required joint stacks.

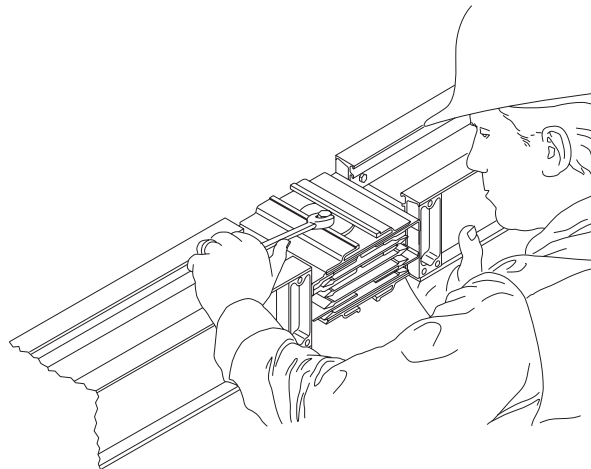

The single-joint bolt is a double-headed break-off bolt. The outer head is 5/8" and the bottom head is 3/4". The double-headed bolt is tightened until the 5/8" outer head twists off (approximately 55 ft. lbs.). This eliminates the need for torque wrenches. The bottom 3/4" head is permanent and can be used for future joint maintenance. Each joint is adjustable by  $\pm 5/8"$ .

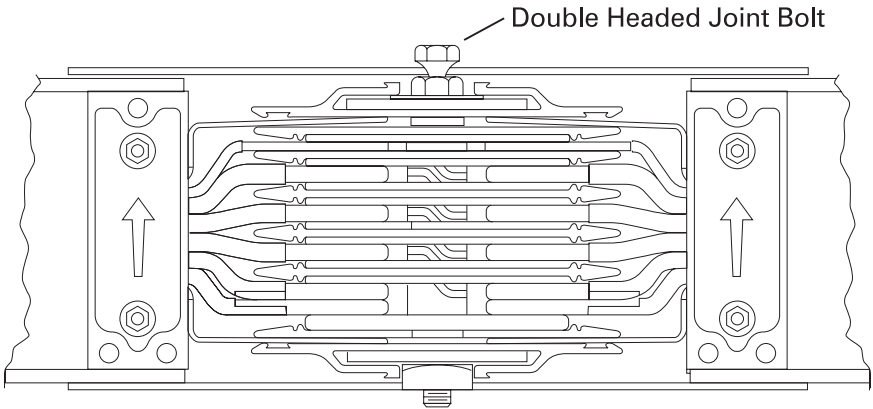

**Elbows**

Elbows, offsets, and tees allow for turns and height changes in the busway system to be made in any direction. An elbow can turn the busway system right or left, up or down. Elbows are supplied with a joint stack and covers.

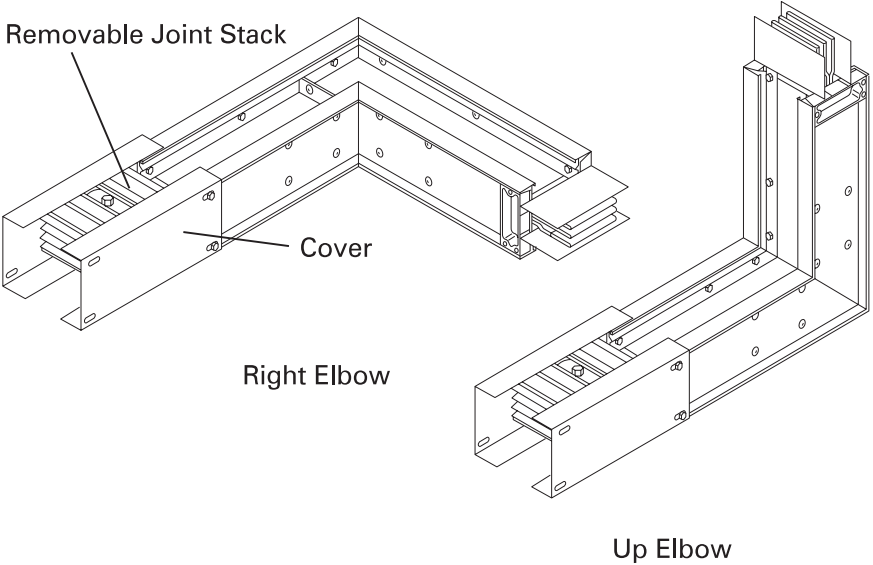

**Combination elbows**

Combination elbows can turn the busway system up or down, and right or left.

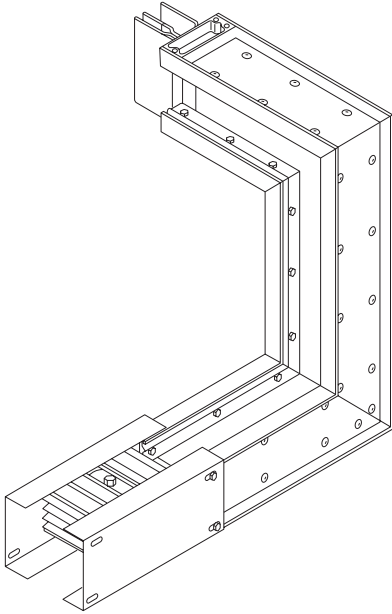

Up, Left Combination Elbow

**Tees**

Tees are used to start a new section of busway in a different direction. Tees can start a new section to the right, to the left, up, or down. Tees are supplied with two joint stacks.

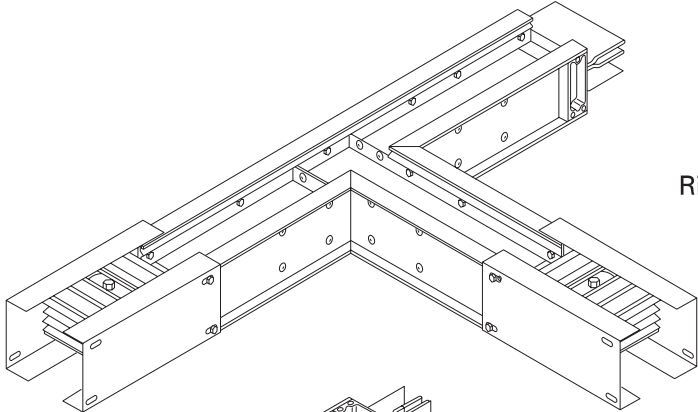

Right Tee

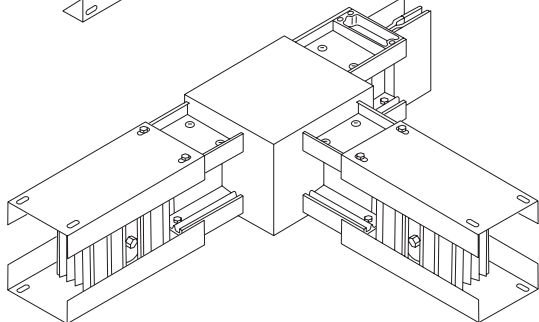

Down Tee

## Crosses

A cross allows a busway run to expand in four directions.

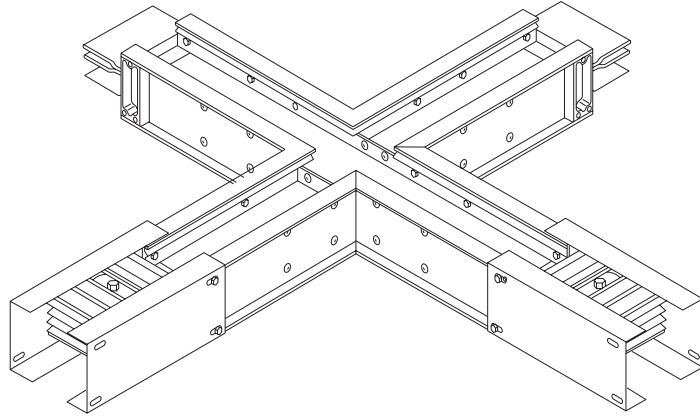

## Offsets

Offsets allow the busway system to continue in the same direction. Offsets can move the busway system to the right, to the left, up, or down. Offsets are supplied with a joint stack.

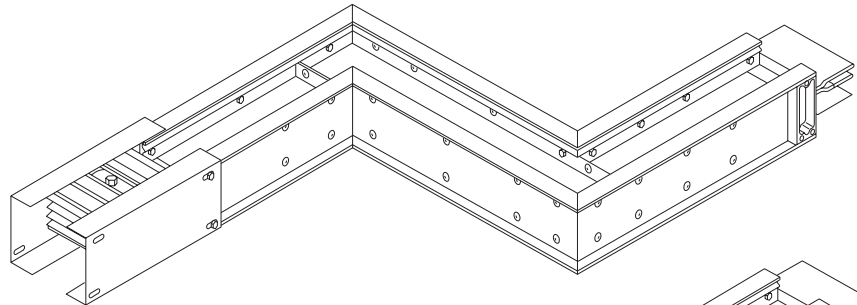

Right Offset

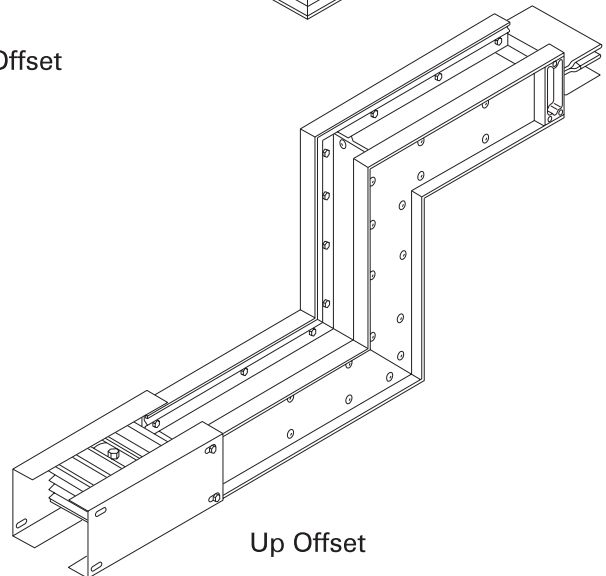

Up Offset

## Cable tap boxes

Tap boxes are used to connect electrical cable to the busway distribution system. End cable tap boxes can be installed at either end of the busway system. They can be used on feeder or plug-in busway.

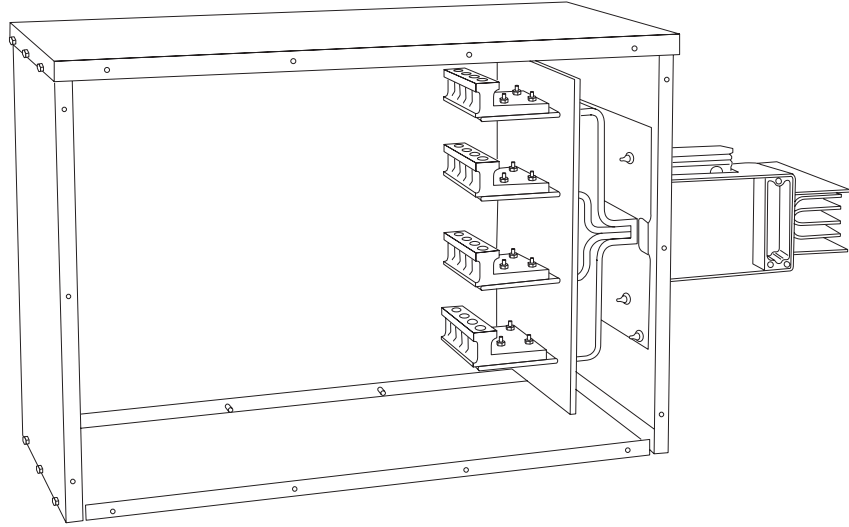

End Cable Tap Box

Center, or plug-in, cable tap boxes can be installed along the length of a busway system. Plug-in cable tap boxes can only be used on plug-in busway.

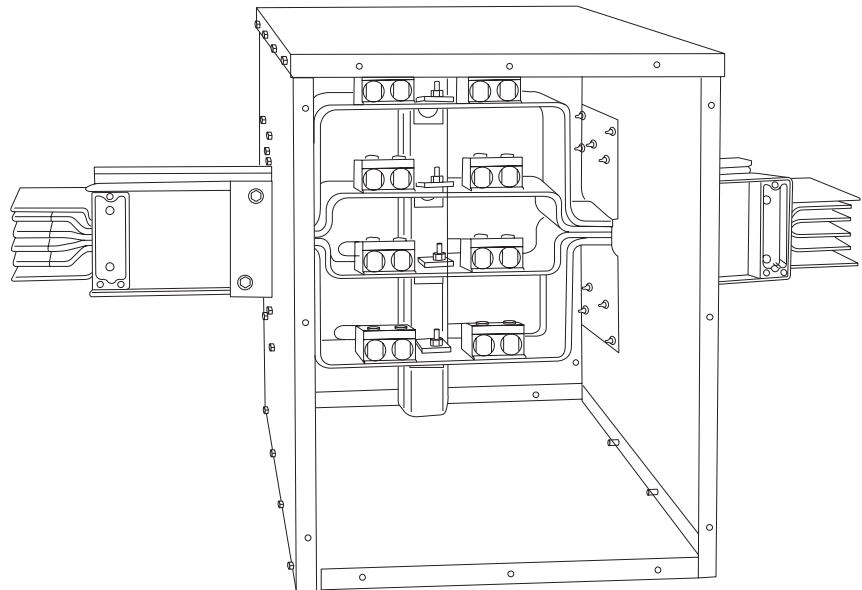

Center Cable Tap Box

## Stubs

Sentron busway standard stubs can be used to connect busway to other Siemens equipment, such as switchgear and switchboards. Sentron busway stubs can be shipped installed in Siemens switchboards and switchgear. This eliminates the field labor required to connect the busway to the switchboard, saving the installer time and money.

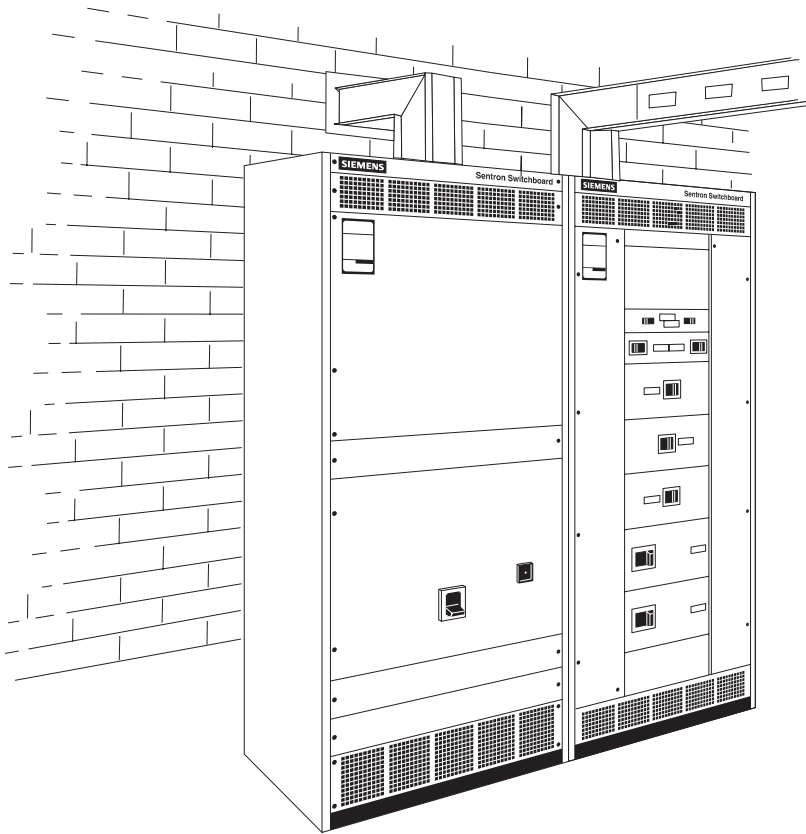

## Flanged ends

Flanged ends are also used to connect busway equipment such as switchgear and switchboards. These can be used with existing equipment. Siemens will furnish the outline drawings of this flanged end to the coordinating switchboard or equipment installer.

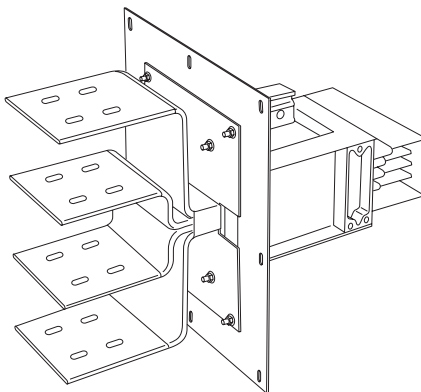

## Service heads

Service heads are used to connect the busway to the electric service. There are two types in the Sentron series. A single service head that has all three phases, or three separate heads, one for each phase.

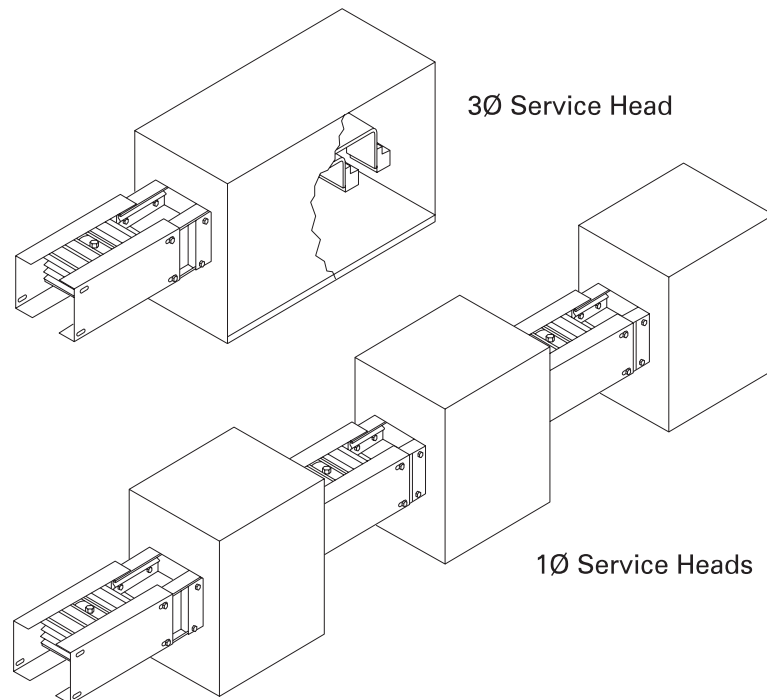

## Riser adaptors

In busway, a riser is a length of vertical busway. Panelboards and meter centers can be mounted directly to risers with an adaptor. In the Sentron series side and front mounted adaptors are available. When Sentron plug-in busway is used as a riser, plug-in receptacles are located only on one side.

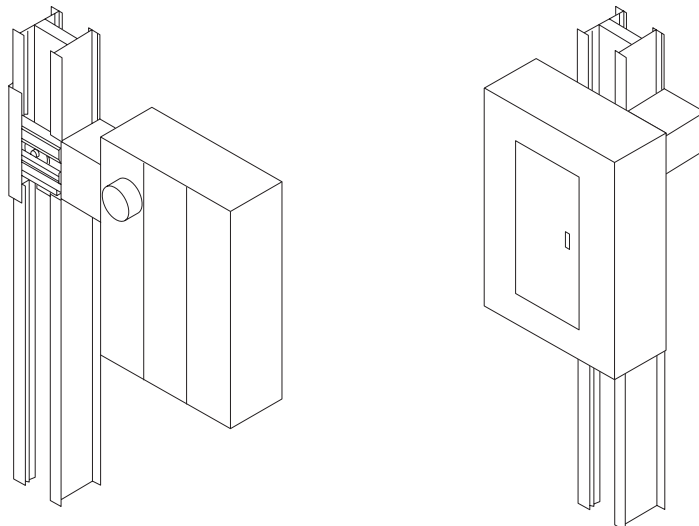

Side Mounted Adaptor

Front Mounted Adaptor

## Phase Rotation

Some applications may require a phase rotation of the power supply to be reversed. The direction of rotation of a 3Ø AC motor, for example, is determined by the phase sequence of the power supply.

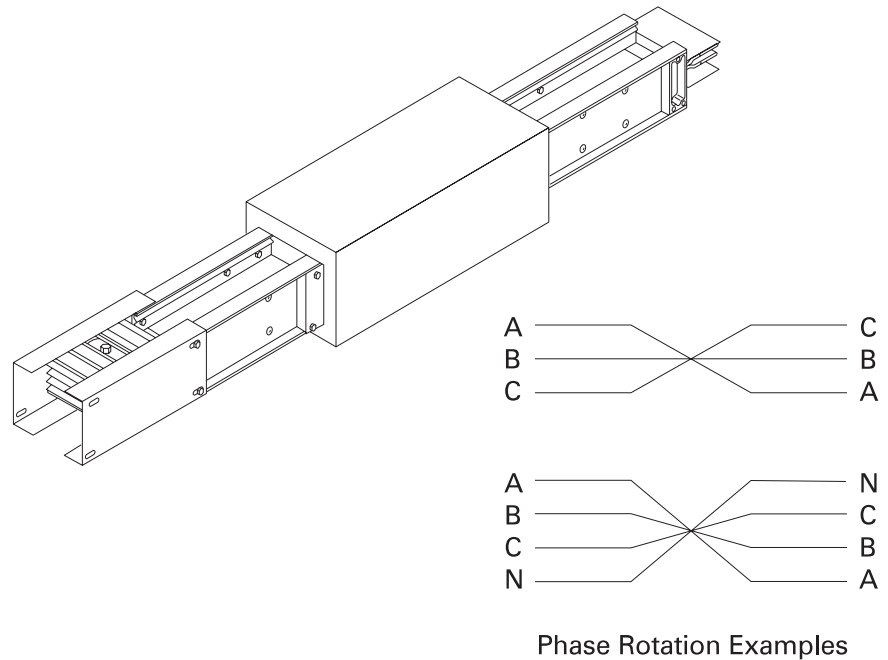

## Reducers

A busway reducer is used to reduce the allowable ampere rating. Money can often be saved by using a lower rated group of sections near the end of a busway run. A branch circuit, for example, does not need as high an ampere rating as the main feeder circuit.

Article 364-11 of the *NEC*<sup>®</sup> states that *overcurrent protection shall be required where busways are reduced in ampacity.*

There is an exception to this article.

*Exception: For industrial establishments only, omission of overcurrent protection shall be permitted at points where busways are reduced in ampacity, provided that the length of the busway having the smaller ampacity does not exceed 50 ft. (15.2 m) and has an ampacity at least equal to 1/3 the rating or setting of the overcurrent device next back on the line, and provided further that such busway is free from contact with combustible material.*

Sentron busway offers fused reducers to meet the requirement of *NEC*<sup>®</sup> Article 364-11, and non-fused reducers when the exception is allowed. Illustrated below is a fused reducer.

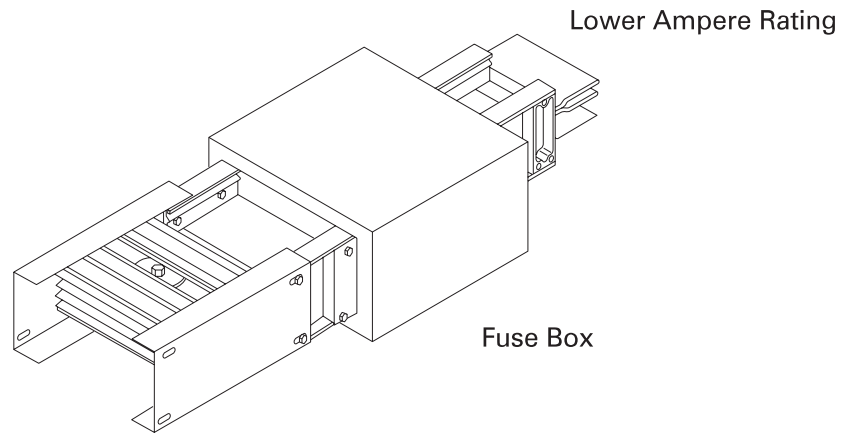

## Expansion fittings

Expansion fittings are used when a busway system crosses an expansion joint in a building, or on long straight runs where both ends are held in a permanent fixed position. The Sentron expansion fitting contains a sliding expansion enclosure. Flexible connectors in the expansion enclosure allow a  $\pm 2$ " movement.

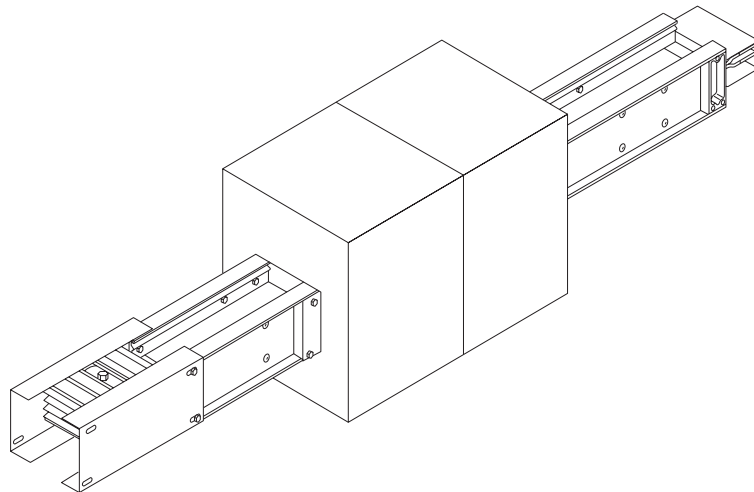

## Bus Plugs

Sentron busway Bus Plugs are available with Siemens Sentron molded case circuit breakers or Siemens fusible switch.

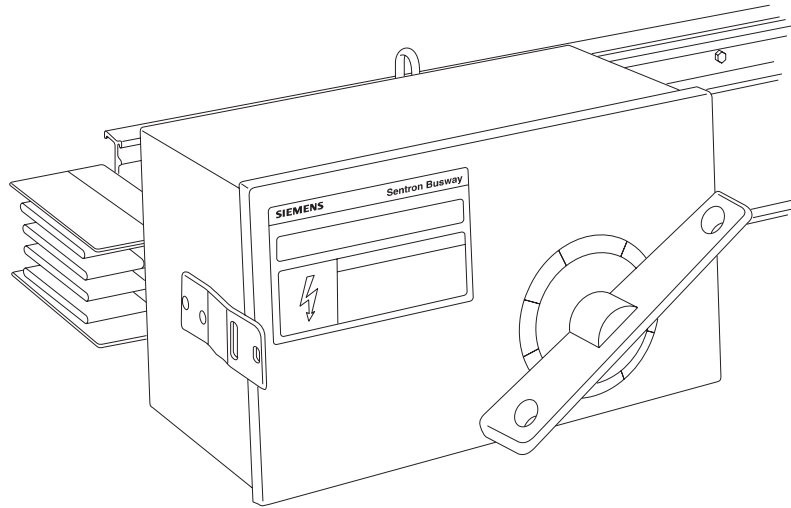

Sentron Bus Plugs are designed with standard wire bending space and extended wire bending space (gutter). Plug-in units can be mounted horizontally or vertically (riser). The front cover handle will rotate 90 degrees to assure the handle is always right side up.

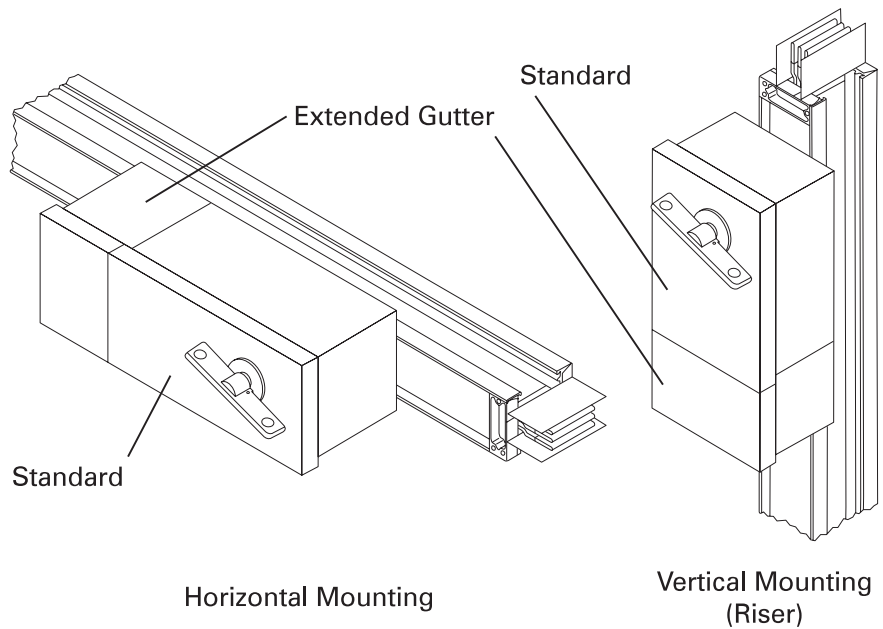

### **In-line disconnect cubicle**

Cubicles provide a means of mounting switches or circuit breakers where power enters or leaves a busway system. In-line disconnect cubicles are used where bolted connections are preferred, or at ampere ratings exceeding the standard plug-in unit ratings.

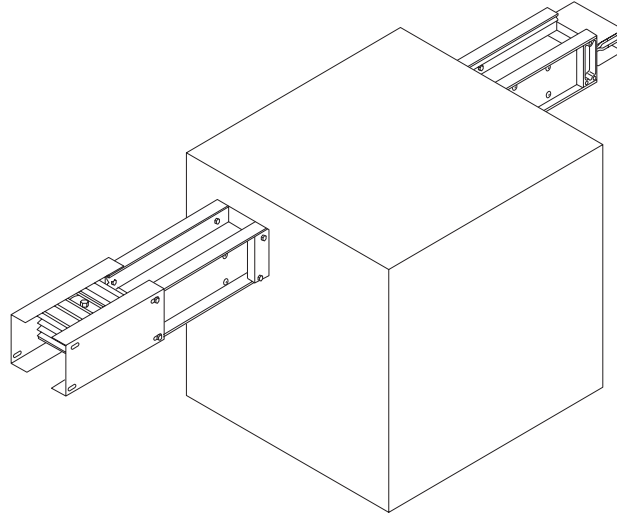

### **End closer**

End closers are used to safely terminate a run of busway and protect the bus bar ends.

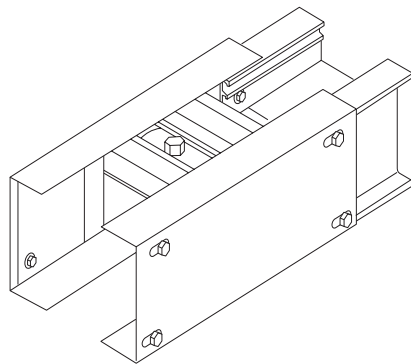

## Hangers

Various hangers are used to support busway. When a vertical run of busway passes through a floor, a floor support is required. Spring hangers provide secure mounting of Sentron busway in riser applications. These hangers counter the weight of the busway on each floor and compensate for minimal building movement and thermal expansion.

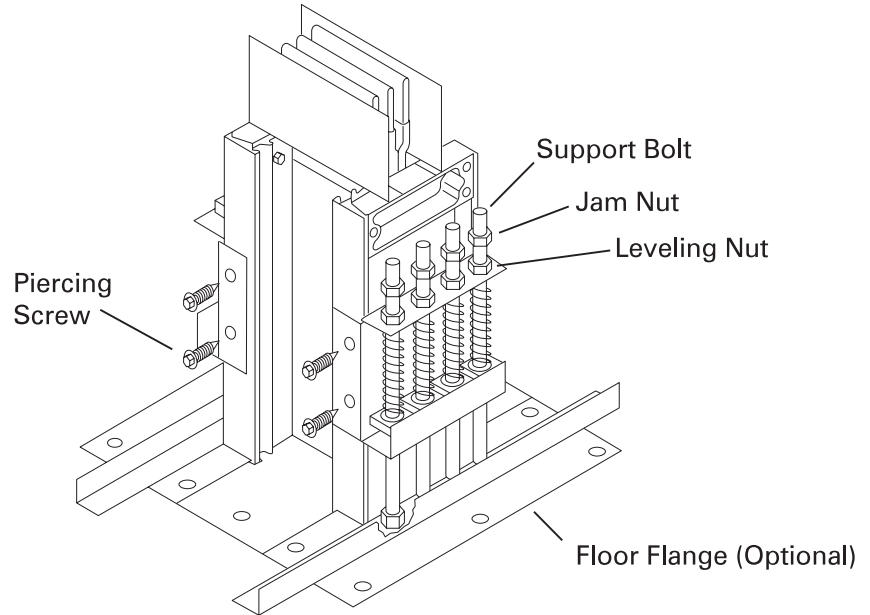

Several types of hangers are available to suspend the busway from the ceiling, structural steel support, or mounted to a wall.

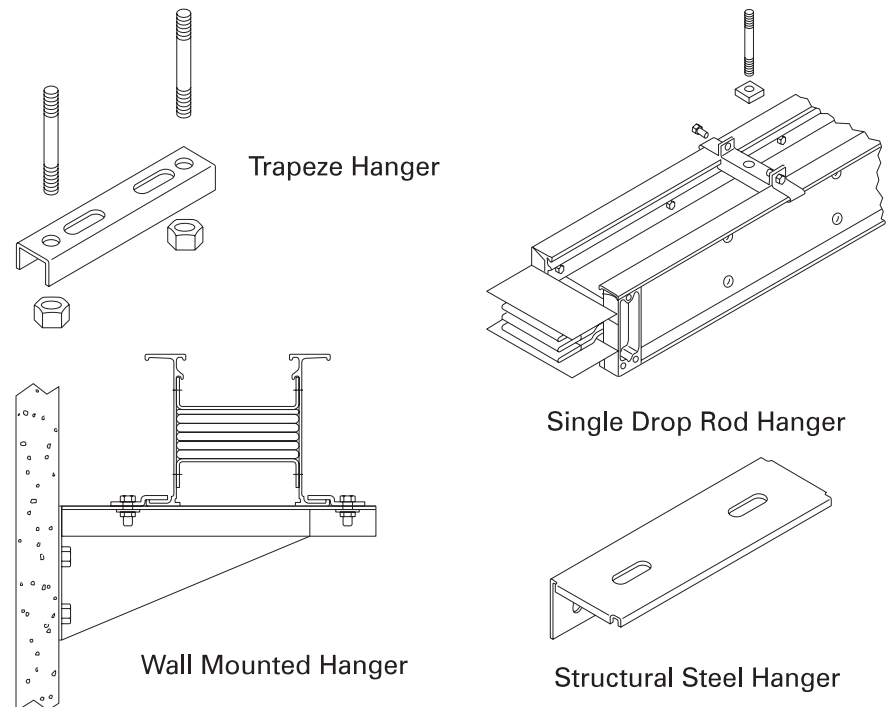

**Flanges**

Wall, ceiling, and floor flanges are designed to close off the area around the busway as it passes through a wall, ceiling, or floor. The flange does not provide an air tight seal around the busway.

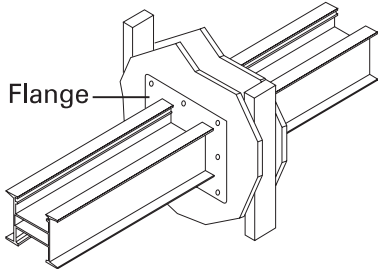

Roof flanges provide a watertight seal when outdoor rated busway enters through a roof. The pitch or angle of the roof must be specified when ordering roof flanges.

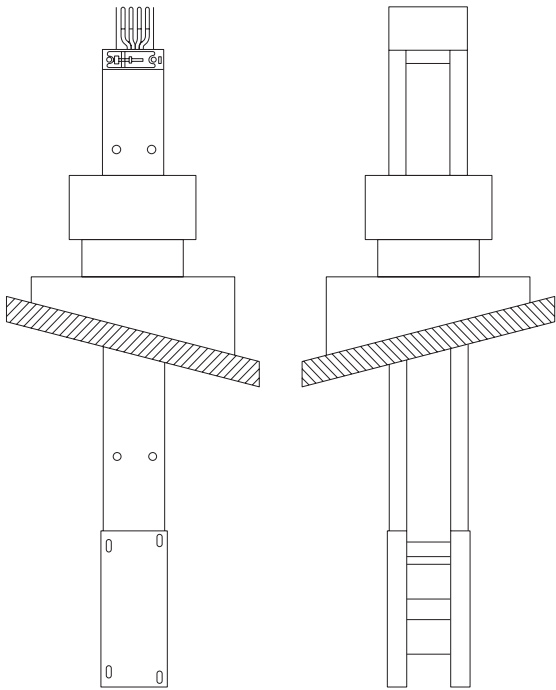

## Review 4

Identify the components in the following illustration:

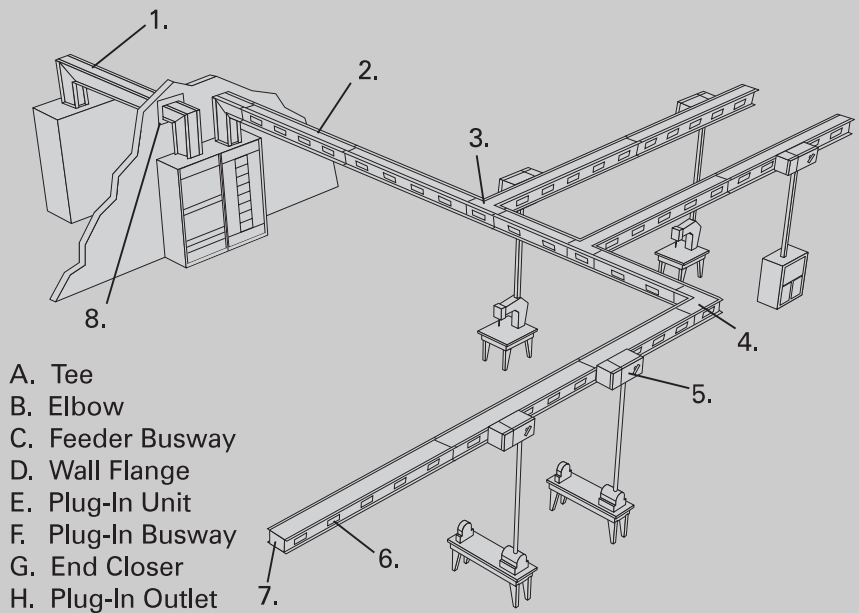

1. \_\_\_\_\_

2. \_\_\_\_\_

3. \_\_\_\_\_

4. \_\_\_\_\_

5. \_\_\_\_\_

6. \_\_\_\_\_

7. \_\_\_\_\_

8. \_\_\_\_\_

# Planning a Busway System

There are several considerations when planning a busway run. The best route would require the fewest fittings and the maximum number of 10' straight sections.

There are a number of techniques to ensure an accurate measurement before purchasing and installing busway. The following procedures are given as an example and are useful in obtaining a correct measurement.

## Measuring stick

A measuring stick can be made from two pieces of lumber clamped together. This can be used to find the height to the underside of pipes, beams, and other obstructions. Although any convenient length will work, it is useful if one piece of lumber is 10' long. This is the measurement of a standard length of busway. Notch the top of the 10' length for a plumb bob string. The diagram shows the measuring stick being used to measure a height. A C clamp is used to secure the measuring stick to a surface. The measuring stick is placed against a vertical surface, and the height is measured from the bottom of the measuring stick to the top of the obstruction. The measuring stick is labeled with 'Total Length' and '10''. A notch is cut into the top of the 10' section for a plumb bob string. The C clamp is labeled 'C Clamp'.

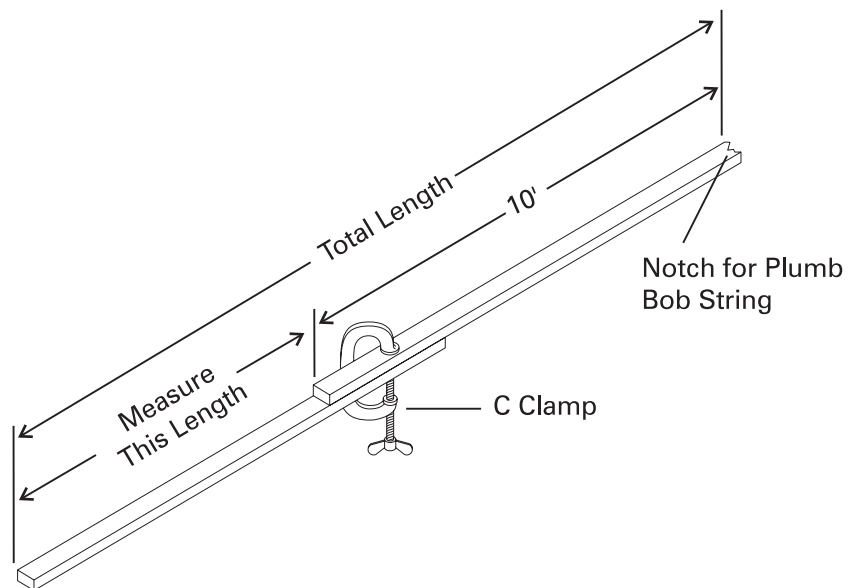

Adding a third piece of lumber to make a right angle will help in determining the top side dimensions.

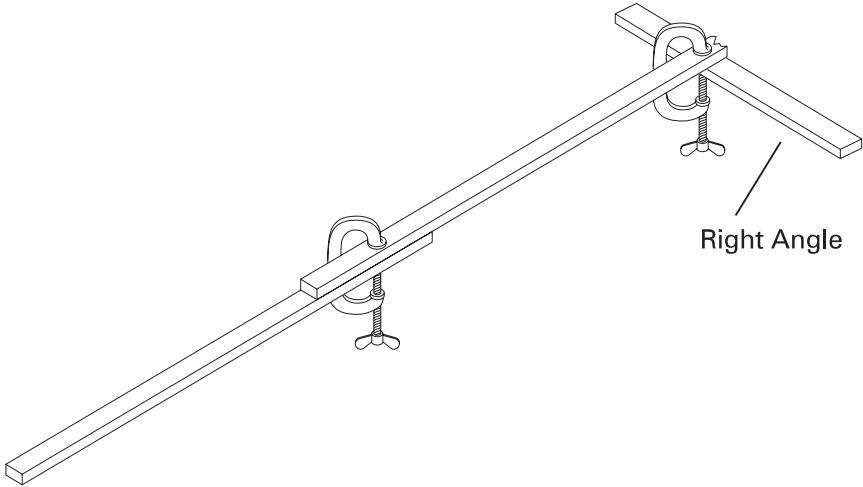

**Laying out a run**

Using the measuring stick, determine the height and location of obstructions. A metal measuring tape is not recommended due to possible contact with a live electrical circuit. Select a route requiring the fewest offsets. The planned route can be laid out on the floor with chalk. Using a plumb bob and the measuring stick, transfer the position of pipes, ducts, beams, and other obstructions to the floor. It will be easier to transfer the planned busway route to paper if significant portions are laid out full scale first.

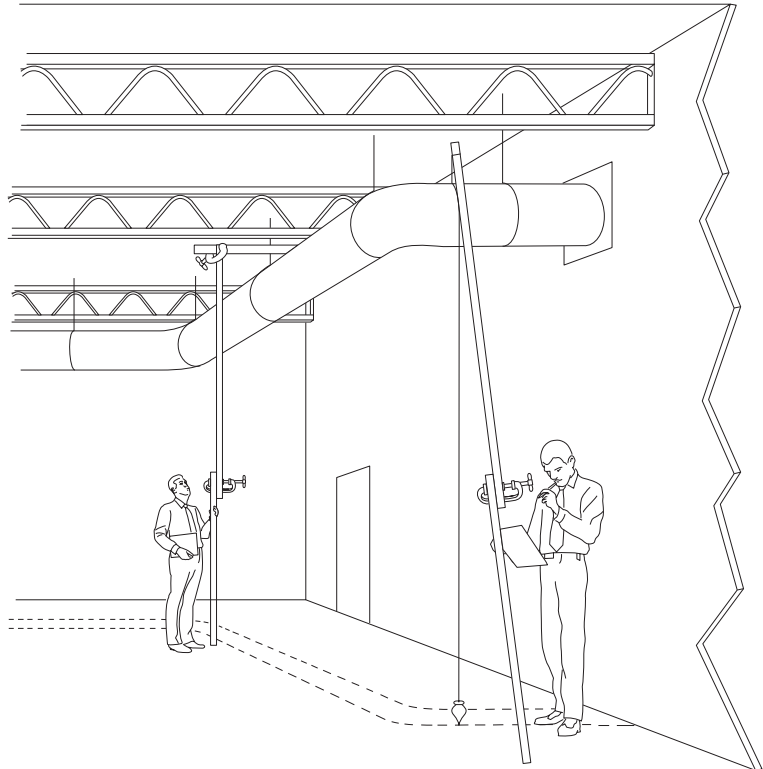

## Walls, ceilings, floors

When piercing a wall, ceiling, or floor find a reference point which is common to both sides and measure from it. This may be a pipe, a wall, or a door.

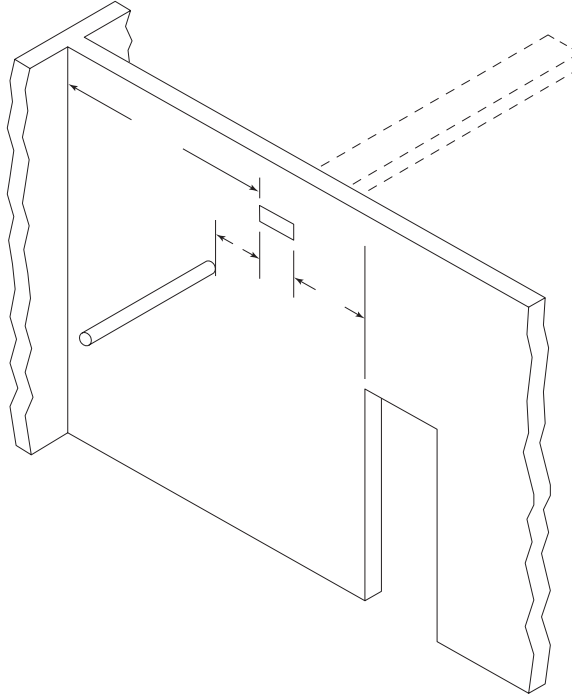

## Sample layout

In the following example, a busway system, connected to a switchboard, will pass through three rooms. The floor to ceiling height is 15' on the first floor, and 12'6" on the second floor. The overall length is 42'. Walls and floors are 6" thick. The switchboard is a standard 90" high. Various types of equipment on the second floor will be connected to the busway through plug-in outlets along the length of the room.

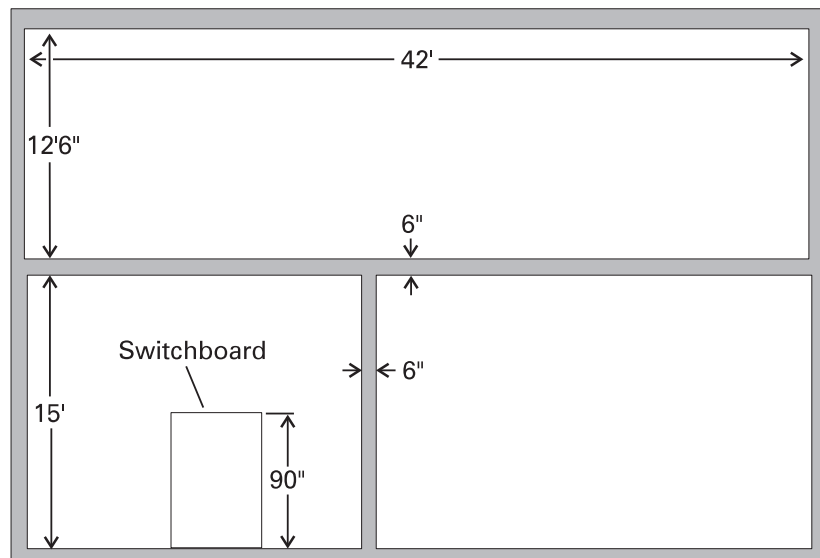

It is determined that a clear space is available 13' above the floor in the switchboard room (5'6" from the top of the switchboard). The clear space extends on the other side of the wall in the second room to the far right wall. It is also clear on the second floor along the far right wall and 10' above the floor for the length of the second floor.

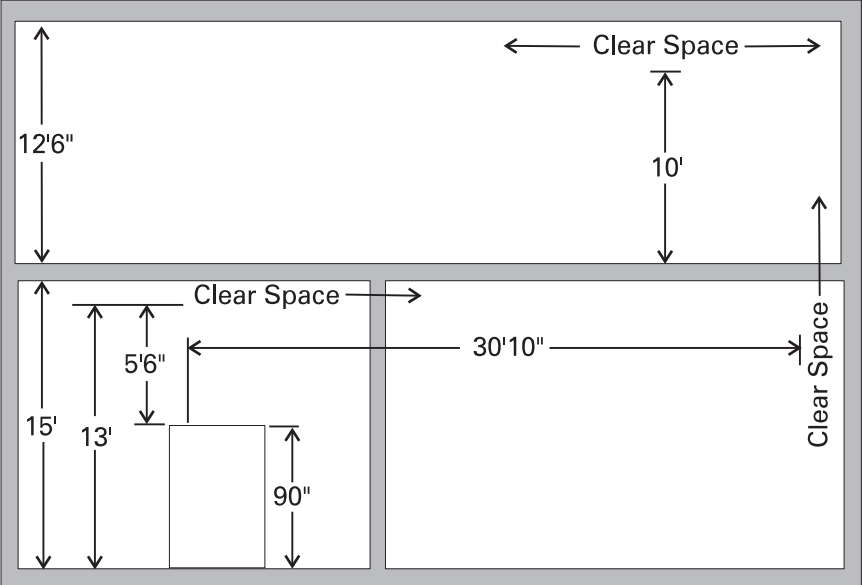

A rough sketch can now be made of the proposed busway system route.

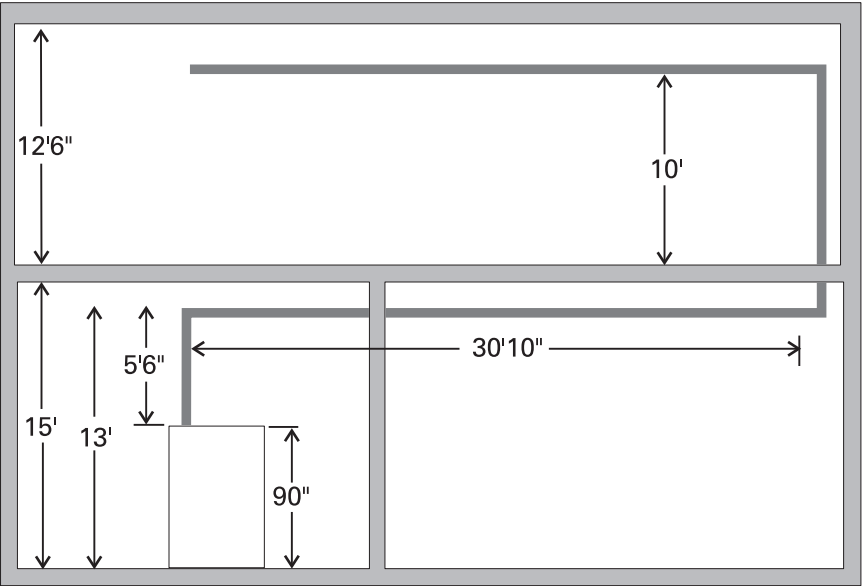

## NEC requirements

An important part of applying a busway system is to be sure that the system meets the requirements of The *National Electrical Code*<sup>®</sup>.

### Article 364-4

According to NEC<sup>®</sup> Article 364-4, *busways shall be installed only where they are located in the open and are visible.*

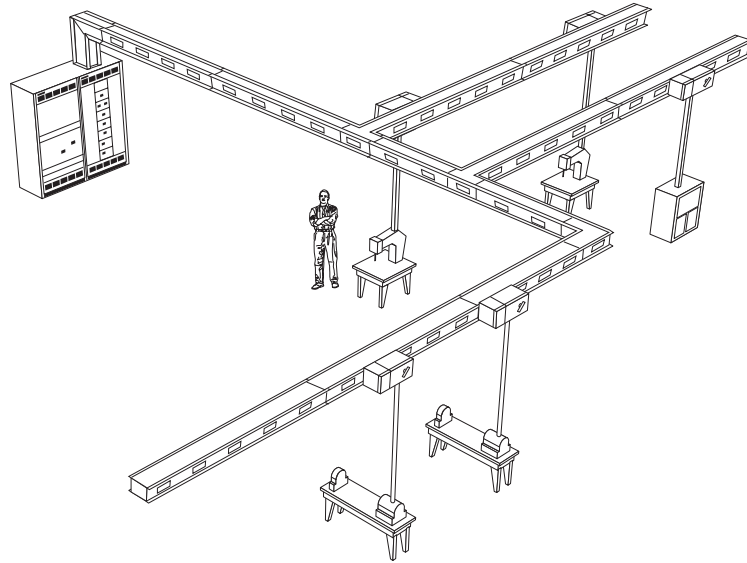

The NEC<sup>®</sup> allows certain exceptions to this rule.

*Exception: Totally enclosed, nonventilating-type busways, installed so that the joints between sections and at fittings are accessible for maintenance purposes, shall be permitted to be installed behind panels where means of access are provided, and:*

- a. *The space behind the access panels is not used for air-handling purposes; or*
- b. *The space behind the access panels is used for environmental air, other than ducts and plenums, in which case there shall be no provisions for plug-in connections, and the conductors shall be insulated.*

Article 364-4 also restricts the use of busway in conditions where it may be damaged or cause damage.

*Busways shall not be installed (1) where subject to severe physical damage or corrosive vapors; (2) in hoistways; (3) in any hazardous (classified) location, unless specifically approved for such use; nor outdoors or in wet or damp locations unless identified for such use.*

#### **Article 364-5**

Article 364-5 requires adequate support for the busway. The following drawing illustrates one type of support available for Siemens Sentron™ busway.

*Busways shall be securely supported at intervals not exceeding 5 ft (1.52 m) unless otherwise designed and marked.*

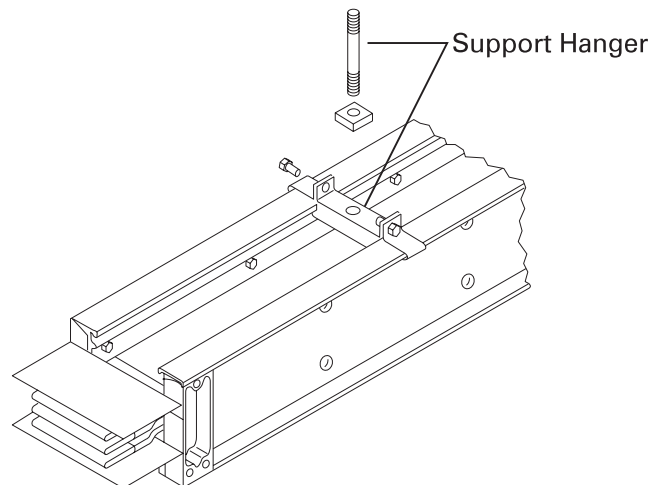

## Article 364-6

Article 364-6 allows busway to pass through walls and floors provided there are no section joints in the wall or floor and vertical busway extends at least 6 feet through the floor.

*It shall be permissible to extend unbroken lengths of busway through dry walls. It shall be permissible to extend busways vertically through dry floors if totally enclosed (unventilated) where passing through and for a minimum distance of 6 ft (1.83 m) above the floor to provide adequate protection from physical damage.*

In addition to *NEC*<sup>®</sup> requirements, Sentron busway requires a minimum of 7" from a wall to a joint where a new section of busway begins. Sentron busway passing through a floor requires a minimum of 16" between the floor and a joint. This space is required for the floor supports.

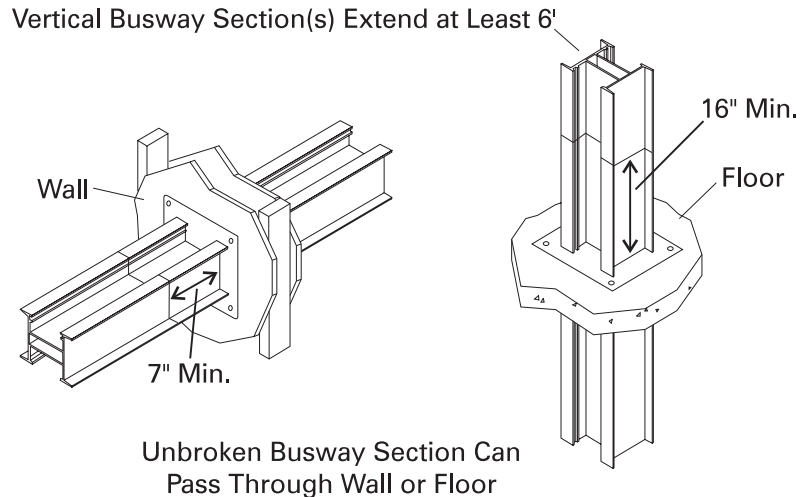

## Article 364-7

Article 364-7 states that *a dead end of a busway shall be closed*. The following drawing illustrates the end closer used on Sentron busway.

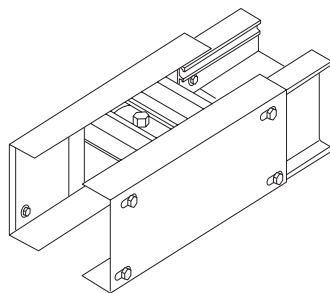

## Minimum clearance

There are certain minimum clearances required when installing busway near a wall, ceiling, or another busway run. It is beyond the scope of this course to cover in detail the minimum clearances of every component. The minimum clearances of Sentron busway components are listed in the *Sentron™ Busway Systems Selection and Application Guide*. Specifications for other systems are listed in their respective selection and application guides.

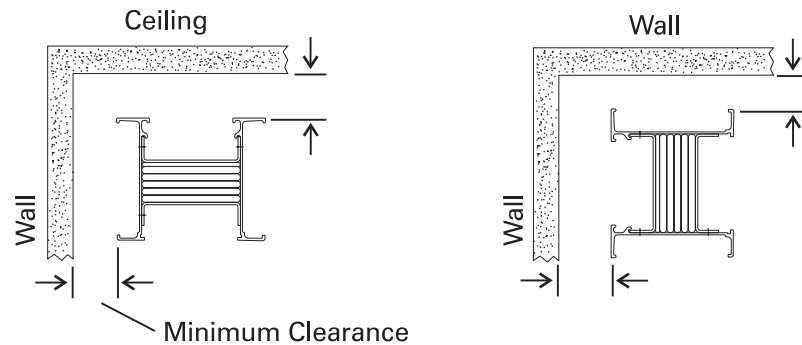

## Dimensions

Component dimensions must also be considered when planning a busway system. The dimensions given in the following examples are for illustrative purposes. For a complete listing of Sentron busway components refer to the *Sentron™ Busway Systems Selection and Application Guide*. Specifications for other systems are listed in their respective selection and application guides.

## Section dimensions

It has already been mentioned that Sentron plug-in busway is available in 4', 6', 8', and 10' sections, and feeder busway is available in lengths from 2' to 10' in increments of 0.125". The height of Sentron busway is 5". The width varies with the maximum amperage rating. The width of one-bar-per-pole Sentron busway varies from 3.9" to 10.9". An 800 ampere aluminum one-bar-per-pole section, for example, would be 4.5" wide.

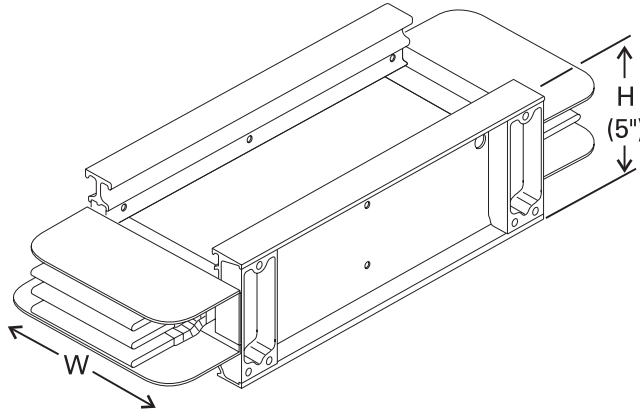

Aluminum			
Ampere Rating	Width (W) In. (mm)	Ampere Rating	Width (W) In. (mm)
225	3.9" (99)	1200	6.5" (166)
400	3.9" (99)	1350	7.5" (191)
600	3.9" (99)	1600	8.6" (219)
800	4.5" (115)	2000	10.9" (277)
1000	5.4" (137)	—	—
Copper			
225	3.9" (99)	1200	5.0" (128)
400	3.9" (99)	1350	5.6" (143)
600	3.9" (99)	1600	6.6" (169)
800	3.9" (99)	2000	8.1" (207)
1000	4.4" (112)	2500	10.6" (270)

## Other component dimensions

Other components, such as elbows, offsets, and tees must also be considered. Right and left elbows, for example, vary from 12" x 12" to 24" x 24". This is due to the variance of bus bar width with amperage rating. An 800 ampere aluminum system, for example, would be 12" x 12". Up or down elbows are 10" x 10".

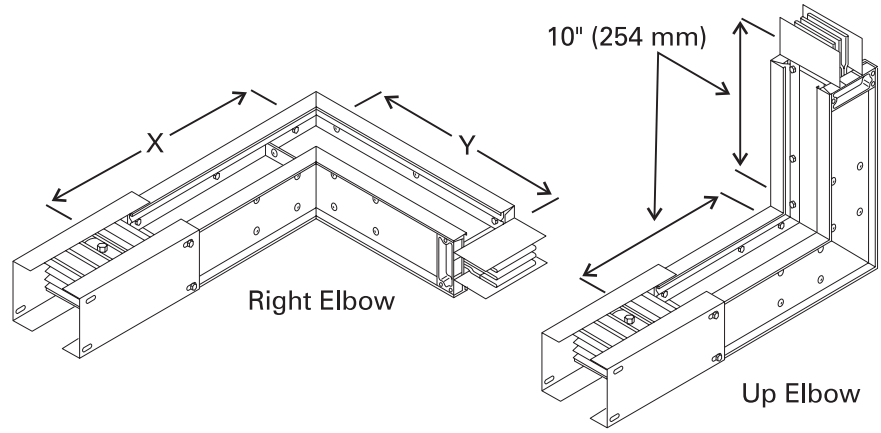

Left or Right Elbows					
Aluminum			Copper		
Ampere Rating	X In. (mm)	Y In. (mm)	Ampere Rating	X In. (mm)	Y In. (mm)
225-1350	12" (305)	12" (305)	225-2000	12" (305)	12" (305)
1600-3000	18" (457)	18" (457)	2500-4000	18" (457)	18" (457)
4000	24" (610)	24" (610)	5000	24" (610)	24" (610)

In the example busway system, the busway will be connected to a switchboard. A flanged end must also be selected. The flanged end is 8" long from the flange to the joint stack.

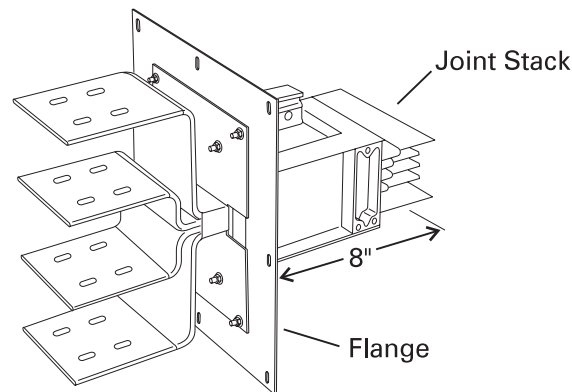

## System assembly

The components can now be selected for the installation. A switchboard flanged end (8"), a 4' length of feeder busway, and one elbow (10" x 10") is selected. The total height is 5'6".

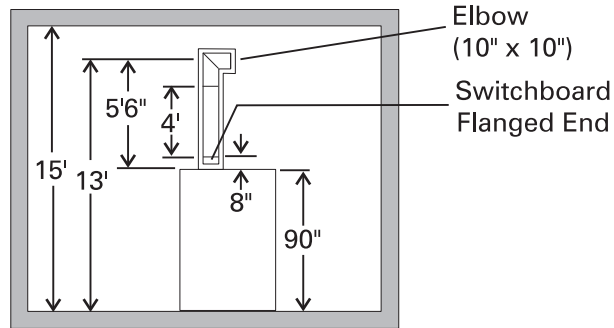

The busway runs horizontally on the first floor 31'8" before making its second turn. Feeder busway is selected because no equipment will be connected to it on the first floor. A second elbow and three 10' feeder sections a second elbow are selected.

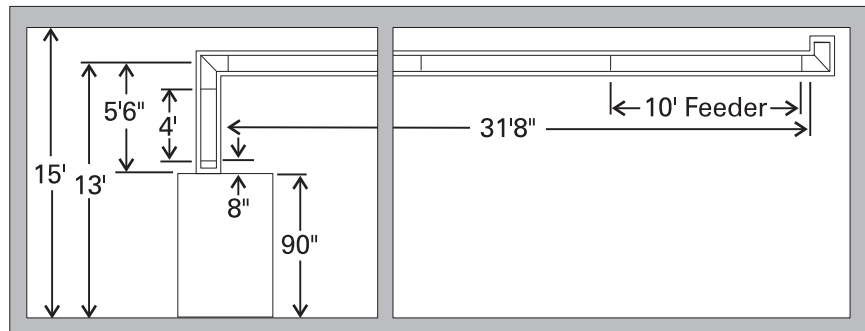

It is 2'6" from the top of the horizontal feeder busway run to the second floor level. The horizontal busway run on the second floor will be installed 10' from the floor, for a total rise of 12'6". One elbow is already installed on the horizontal feeder busway run on the first floor. A second elbow will be installed at the top of the vertical riser. Each has a length of 10". The vertical riser, therefore, is 10'10" (12'6" - 20").

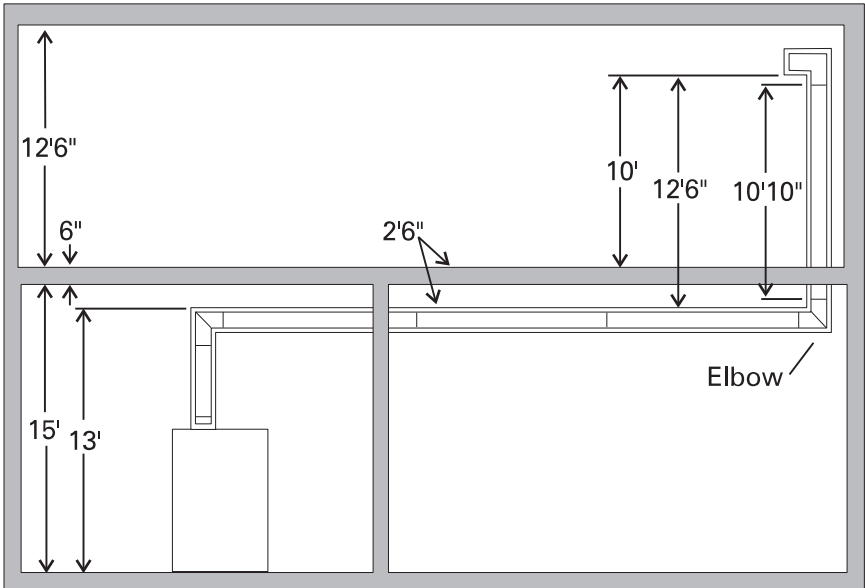

A length of riser busway is required other than a standard length. One solution might be to select a 6' and a 4'10" section. Recall that in addition to the standard lengths of 4', 6', 8', and 10', Sentron feeder busway comes any length from 2' to 10' in 0.125" increments.

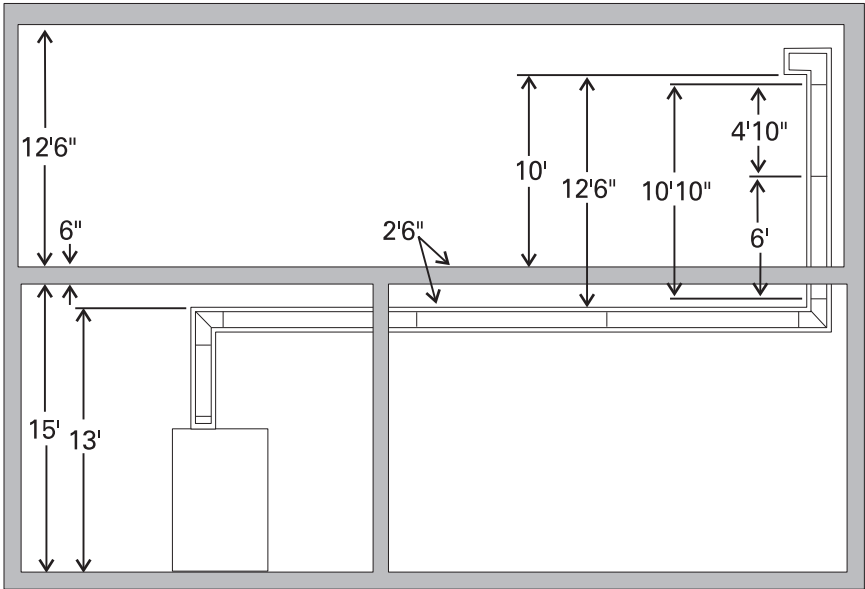

The busway run is completed with three 10' plug-in sections on the second floor.

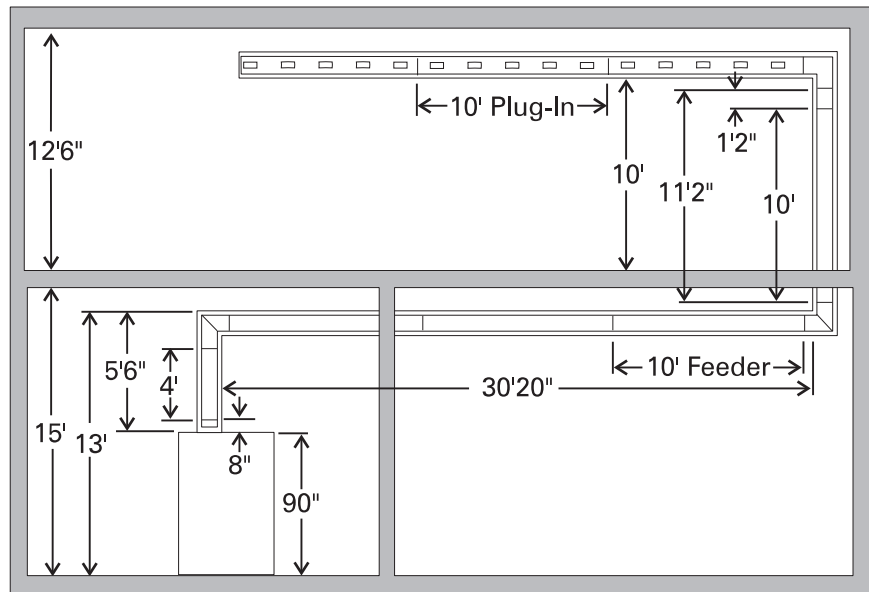

An end closer, wall and floor flanges, floor support, hangers, and the desired number of plug-in units finish the system. In this example three plug-in units were used.

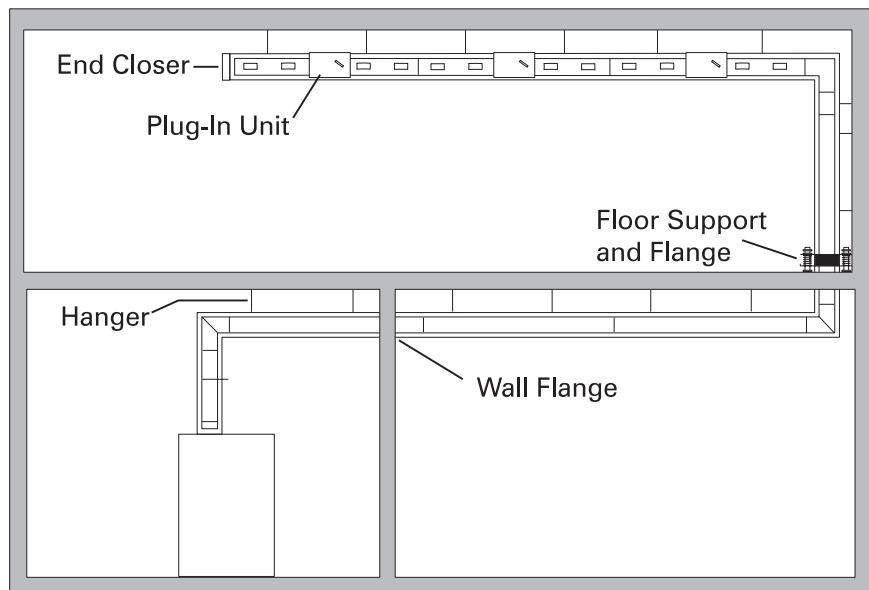

## Information needed to order busway

The following information is needed when planning a busway installation or expansion:

- Description of application
- Type of busway
- Voltage and number of conductors
- Maximum current
- Length and configuration of run
- Location and type of power supply to busway
- Number of hangers
- Type and number of tap-off devices (tees, crosses)
- Type and number of accessories

## Review 5

1. According to *NEC*<sup>®</sup> Article 364-7 a dead end of a busway shall be \_\_\_\_\_ .
2. Dimensions of Sentron busway can be found in the \_\_\_\_\_ .
3. A right elbow with copper bus bars, rated at 5000 amperes has an X measurement of \_\_\_\_\_ inches and a Y measurement of \_\_\_\_\_ inches.
4. According to *NEC*<sup>®</sup> Article 364-5 busway shall be securely supported at intervals not exceeding \_\_\_\_\_ feet unless the busway is otherwise designed and marked.
5. According to the *National Electrical Code*<sup>®</sup> it \_\_\_\_\_ to extend unbroken lengths of busway through dry walls.
  - a. is permissible
  - b. is not permissible

# Cable/Conduit Conversion

Busway can be used in many applications where cable and conduit are more commonly used. The question arises, "Why use busway instead of conventional cable and conduit?"

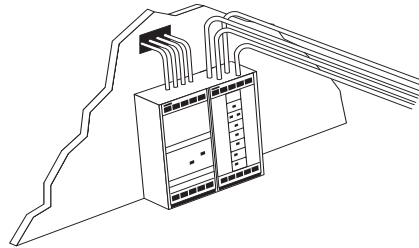

Conduit

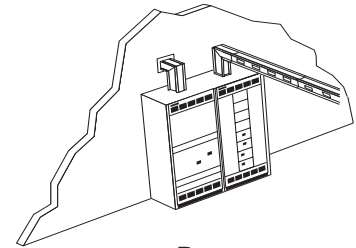

Busway

## Benefits of busway

There are several reasons why busway may be a better choice over cable and conduit. Busway provides greater flexibility by allowing equipment to be connected anywhere along the run on 24" centers. Equipment can be easily disconnected and moved to a new location without major rewiring.

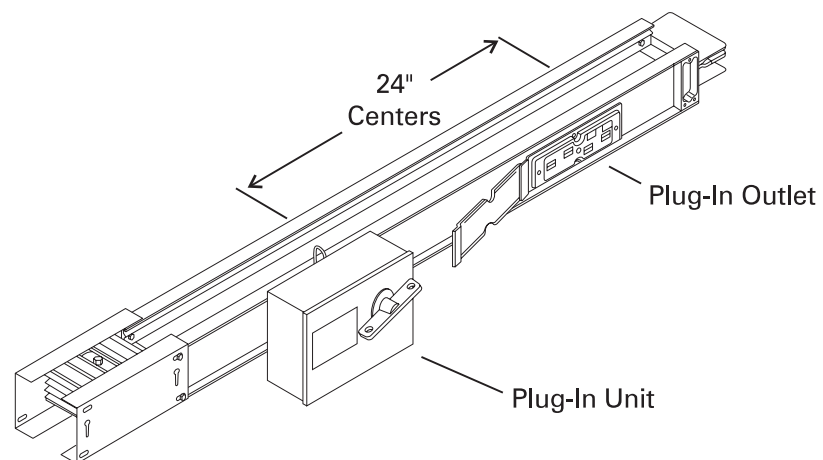

Busway has a smaller cross section. This means less installation space is required. Sentron™ busway with aluminum bus bars rated at 1000 amperes, for example, occupies a much smaller space than a comparable cable and conduit installation. The smaller cross section also means that busway is lighter in weight, by as much as half, which means less loading on the building.

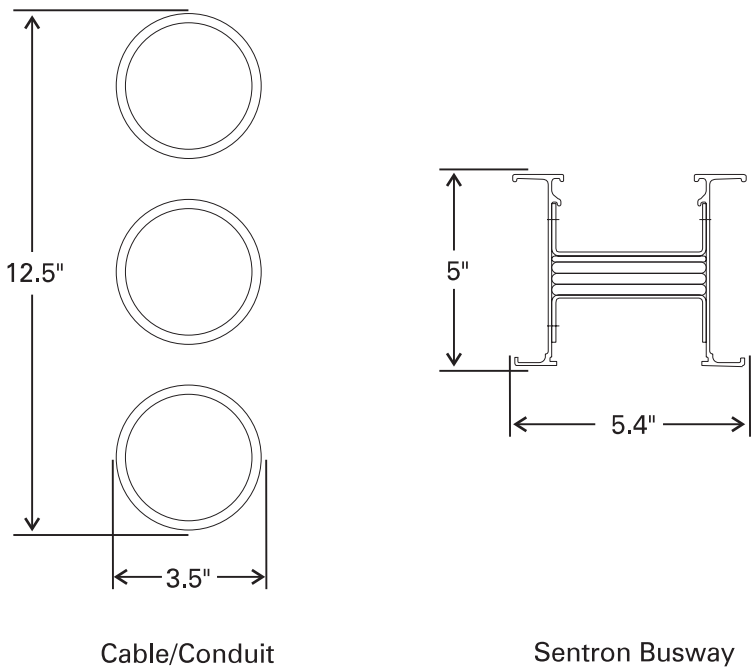

The installed cost of busway is typically less than cable and conduit. Busway is easier to install. Sections are simply hung and joined together using readily available hardware. Total installed costs associated with using Sentron busway over cable and conduit typically results in 20 - 30% lower installed cost.

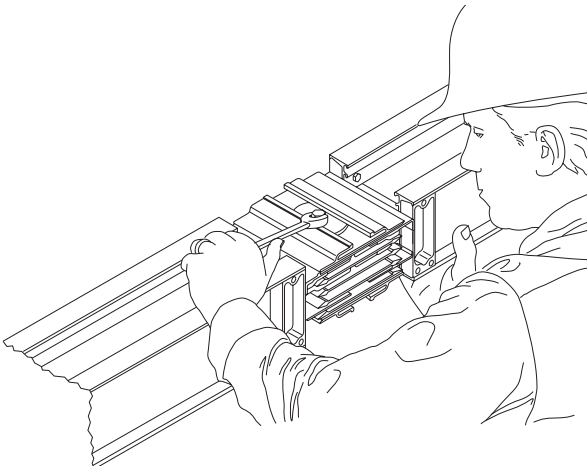

## Sentron busway estimating program

A software program, available from Siemens, compares the total installed price of cable and conduit to Sentron busway.

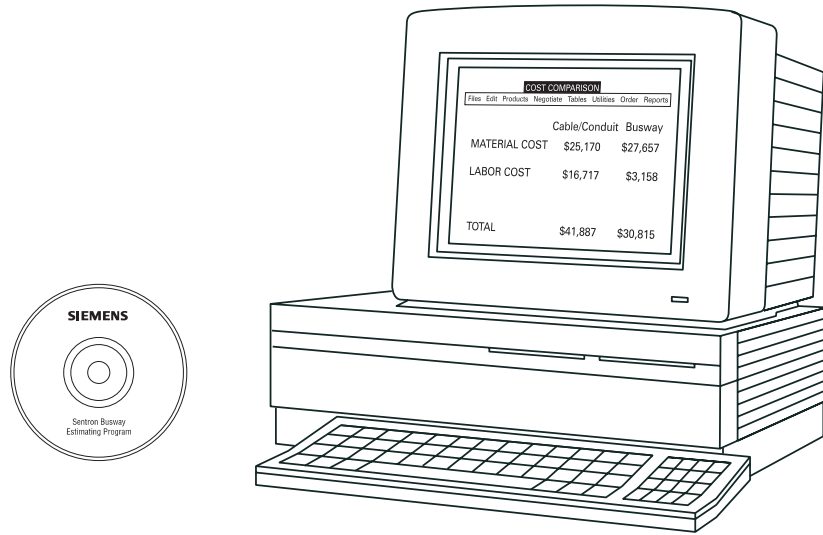

## Comparison example

The following table shows one example of the cost savings of busway over cable and conduit. The job calls for a 500 foot run of 1350 amperes. A hypothetical labor rate of \$37.15 an hour is used. It will take an estimated 455 hours to install the cable and conduit. It will take an estimated 134 hours to install Sentron busway. The total savings, by using Sentron busway, is \$12, 693.

Material	Material Cost	Installation Labor	Total Installed Cost
Cable/ Conduit	\$73,977	\$16,925 (455 hrs. @ \$37.15/hr)	\$90,902.24
Sentron Busway	\$73,212	\$4,996 (134 hrs. @ \$37.15/hr)	\$78,208.89
<b>Savings with Sentron</b>			<b>\$12,693</b>

# XL-U Busway

XL-U<sup>®</sup> is available in both feeder and plug-in busway with ratings of 225 to 5000 amperes with aluminum bus bars or 225 to 6500 amperes with copper bus bars. Maximum voltage is 600 volts. XL-U feeder busway is available in either indoor or outdoor types, ventilated or non-ventilated (totally enclosed). XL-U plug-in busway is indoor only and can be ventilated or non-ventilated. XL-U is available in 3Ø3W and 3Ø4W. A ground bus is standard on the ventilated and optional on the non-ventilated design.

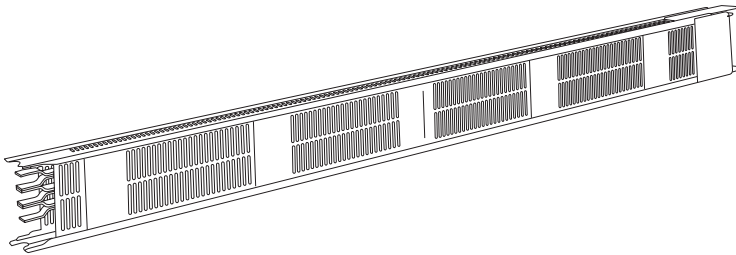

## Paired phases

XL-U is available with a paired-phase bus bar scheme. Bus bars are grouped in pairs so that AC current in each pair is nearly equal in magnitude and opposite in direction. Two bus bars per phase are used. Phase C is paired with phase A, phase A is paired with phase B, and phase B is paired with phase C. The result is a complete magnetic field cancellation. Current is balanced and temperature rise is kept to a minimum. Voltage drop is reduced. XL-U busway can be used on any application within its current rating but it is usually used for long runs where end-of-run voltage is critical. Due to its paired-phase design, XL-U busway is known throughout the industry as the best product available for welder loads.

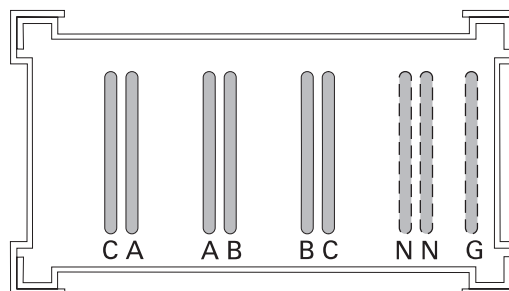

## Sections and components

XL-U feeder busway sections can be supplied in any length from 14" to 10'. XL-U Plug-in busway is available in 4', 6', 8', and 10' sections. Elbows, tees, crosses, end closers, wall flanges, tap boxes, flanged end connections, switchboard connections, bus plugs, reducers, and hangers are available.

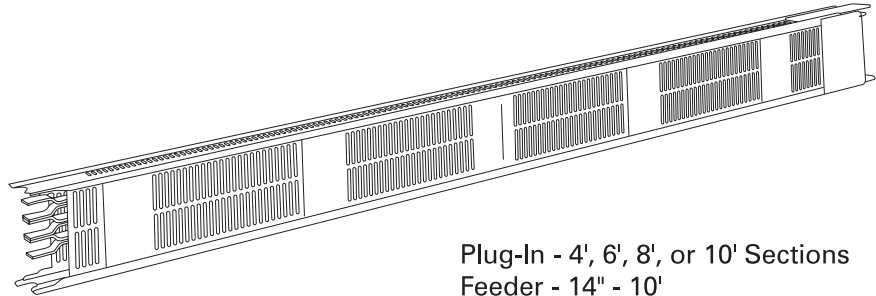

Plug-In - 4', 6', 8', or 10' Sections  
Feeder - 14" - 10'

## Joint stack

XL-U busway uses a joint stack, similar to the Sentron™ busway, to connect sections together. The joint stack bolt is secured with a recommended 35 ft. lbs. of torque.

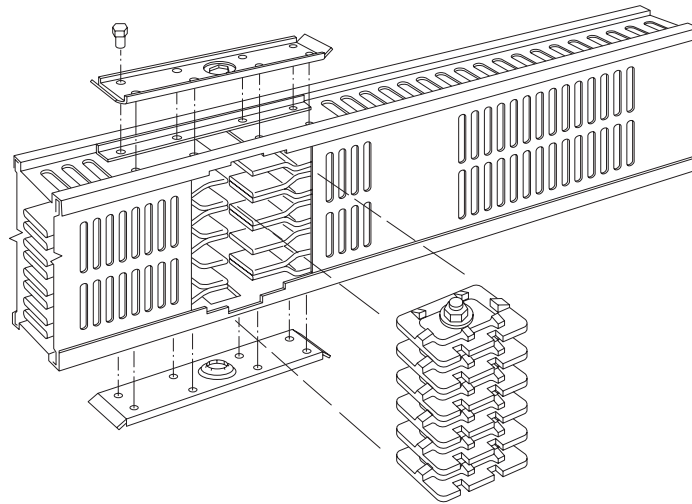

## One bar per phase

XL-U busway is available from 225 to 600 amperes. The number of bus bars and the dimensions depends on the maximum current rating. XL-U busway can be mounted vertically or horizontally, either edgewise or flatwise. The cross sections illustrated below are shown edgewise mounted. The "W" dimension varies with the current rating. There are two maximum current ratings for XL-U, UL and standard rating. XL-U busway is available in a one-bar-per-phase configuration for the maximum current ratings shown in the following table.

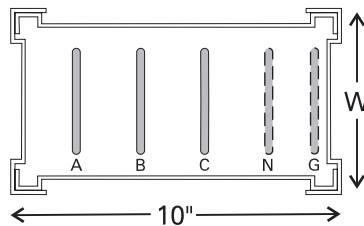

W	Bus Bars			Copper Ampere Rating					
	Number of Conductors			Vent. Bars on Edge		Vent. Bars Flat		Totally Enclosed	
	Per Ø	N	G	UL Rating	Std. Rating	UL Rating	Std. Rating	UL Rating	Std. Rating
4.5"	1	1	1	225	225	225	225	225	225
4.5"	1	1	1	400	400	400	400	400	400
4.5"	1	1	1	600	600	600	600	600	600
				Aluminum Ampere Rating					
4.5"	1	1	1	225	225	225	225	225	225
4.5"	1	1	1	400	400	400	400	400	400
5.5"	1	1	1	600	600	600	600	600	600

Ground Bus Capacity Maximum - 100%

## Two bars per phase

XL-U busway is available in a two-bar-per-phase, paired-phase configuration for the maximum current ratings shown in the following table.

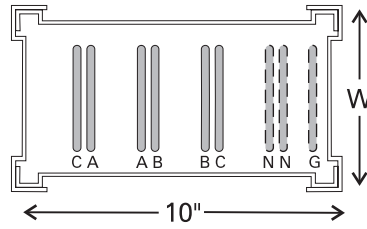

W	Bus Bars			Copper Ampere Rating					
	Number of Conductors			Vent. Bars on Edge		Vent. Bars Flat		Totally Enclosed	
	Per Ø	N	G	UL Rating	Std. Rating	UL Rating	Std. Rating	UL Rating	Std. Rating
4.5"	2	2	1	800	800	800	800		
4.5"	2	2	1	1200	1200	1000	1000	800	800
4.5"	2	2	1	1450	1350	1200	1200	1000	1000
5.5"	2	2	1	1700	1600	1350	1350	1100	
5.5"	2	2	1	2000	2000	1600	1600	1250	1200
				Aluminum Ampere Rating					
4.5"	2	2	1	800	800	800	800		
4.5"	2	2	1	1000	1000	900		800	800
5.5"	2	2	1	1250	1200	1000	1000	900	
5.5"	2	2	1	1400	1350	1200	1200	1000	1000

Ground Bus Capacity Maximum - 50%

### Four bars per phase

At higher current ratings bus bars are doubled up. Four bars per phase are used in the current ratings shown in the following table. Note that paired-phasing is still used.

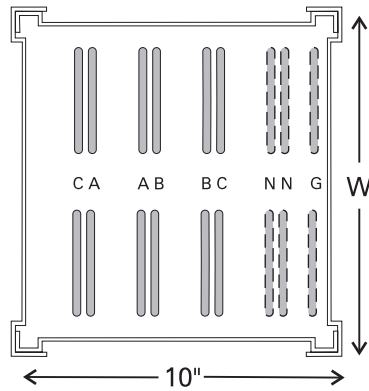

W	Bus Bars			Copper Ampere Rating					
	Number of Conductors			Vent. Bars on Edge		Vent. Bars Flat		Totally Enclosed	
	Per Ø	N	G	UL Rating	Std. Rating	UL Rating	Std. Rating	UL Rating	Std. Rating
7.5"	4	4	2	2300		2000		1400	1350
7.5"	4	4	2	2700	2500	2300	2000	1600	1600
9.5"	4	4	2	3000	3000	2500	2500	1900	
9.5"	4	4	2	3500	3500	2800	2800	2100	2000
				Aluminum Ampere Rating					
7.5"	4	4	2	1700	1600	1500	1350		
7.5"	4	4	2	2000	2000	1700	1600	1200	1200
9.5"	4	4	2	2300		1900		1400	1350
9.5"	4	4	2	2500	2500	2100	2000	1600	1600

Ground Bus Capacity Maximum - 50%

## Eight bars per phase

To accommodate even higher current levels eight bars per phase are used.

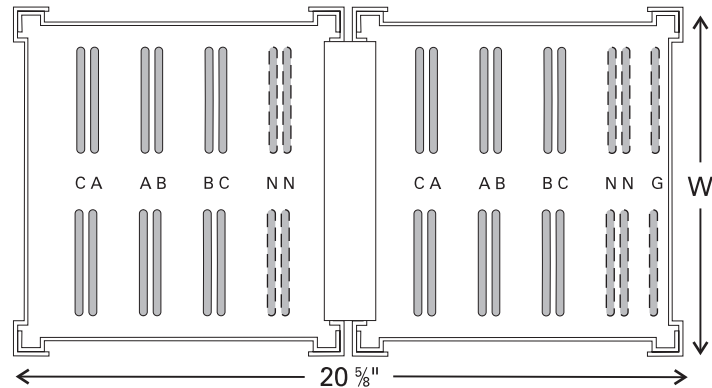

Bus Bars		Copper Ampere Rating							
		Number of Conductors			Vent. Bars on Edge		Vent. Bars Flat		Totally Enclosed
W	Per Ø	N	G	UL Rating	Std. Rating	UL Rating	Std. Rating	UL Rating	Std. Rating
7.5"	8	8	2	4400	4000	4000	4000	2700	2500
7.5"	8	8	2	5200	5000	4600	4500	3200	3000
9.5"	8	8	2	6000	6000	5000	5000	3700	3500
9.5"	8	8	2	6500	6500	5700	5500	4100	4000
		Aluminum Ampere Rating							
7.5"	8	8	2	3300	3000	3000	3000	2000	2000
7.5"	8	8	2	3900	3500	3500	3500	2500	2500
9.5"	8	8	2	4500	4000	3900		2750	
9.5"	8	8	2	5000	5000	4200	4000	3100	3000

Ground Bus Capacity Maximum - 25%

## Components

The following components are available for XL-U busway:

- Hangers
- End closers
- Flanged ends
- Plug-in and center cable tap boxes
- Elbows
- Offsets
- Tees
- Crosses
- Reducers and expansion sections
- Bus plugs (circuit breaker, fusible)

# XJ-L Busway

When an application needs a horizontal run of plug-in busway with a current rating that does not exceed 200 amperes, Siemens XJ-L™ would be a good choice. XJ-L busway is available with 100 or 200 ampere capacities, three-phase, three-wire (3Ø3W), 600 VAC or three-phase, four-wire (3Ø4W), 480 VAC. The neutral bus bar in the 3Ø4W type is rated for 100%. XJ-L busway is available in 2, 5, and 10' lengths. There are up to 12 plug-ins per 10' length. Plug-ins are located in alternate positions from side-to-side.

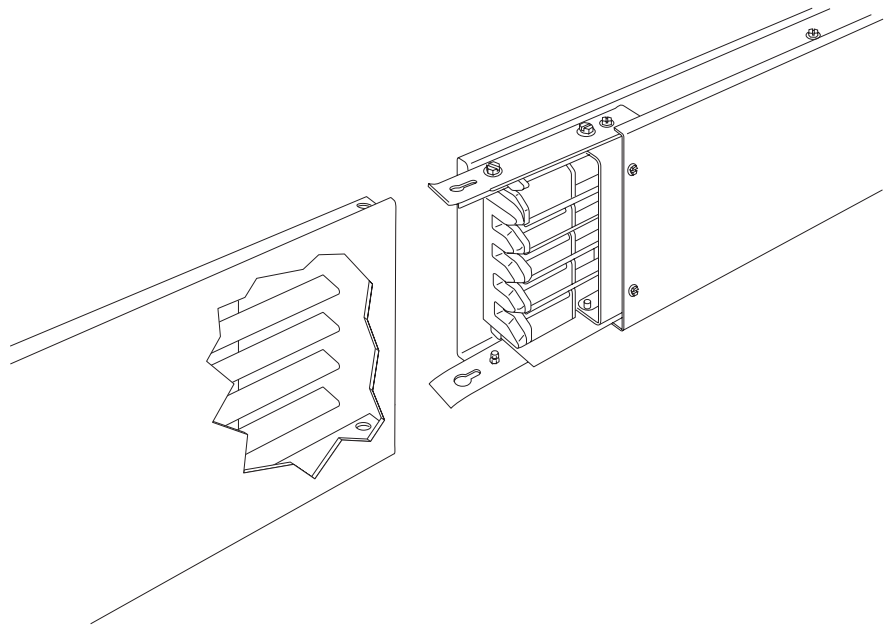

## Installation

All XJ-L busway sections mate together end-to-end with overlapping joints which are held in place by integral spring pressure clips.

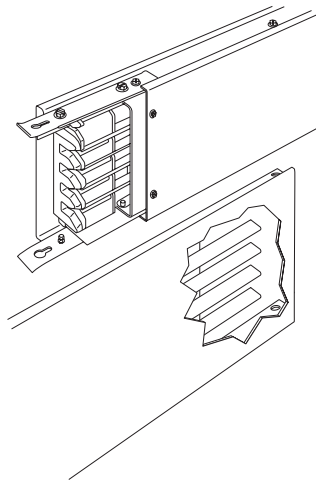

The sections are bolted together with captive screws.

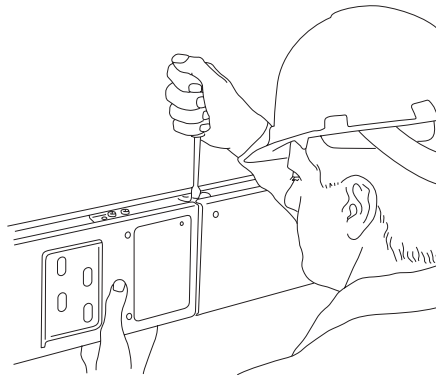

## Components

The following components are available for XJ-L busway:

- Hangers
- End closers
- Flanged ends
- Plug-in and center cable tap boxes
- Elbows
- Tees
- Crosses
- Bus plugs (circuit breaker, fusible)

## XQ-R bus plug

XQ-R bus plugs serve both 120 and 240 VAC needs. This is useful for computer applications, laboratory/test facilities, schools, hospitals, and machine shops.

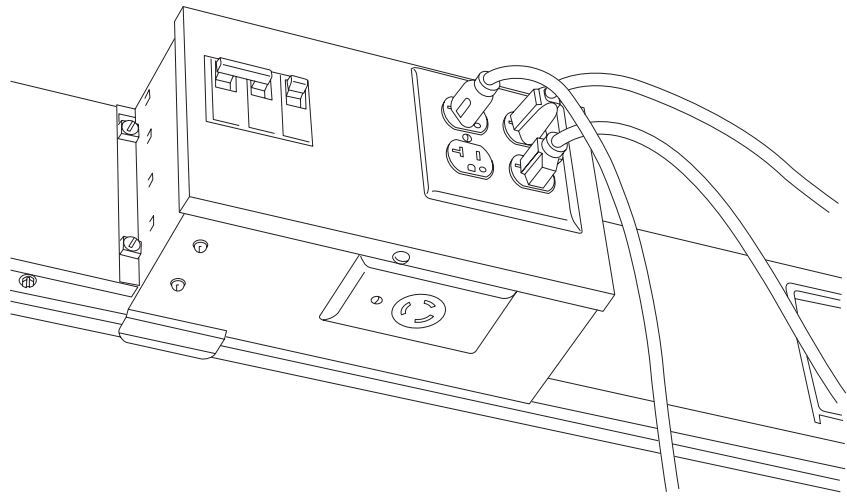

## Review 6

1. The installed cost of busway is typically \_\_\_\_\_ than cable and conduit.
  - a. more
  - b. less
2. The maximum current rating available with XL-U busway with aluminum bus bars is \_\_\_\_\_ amperes.
3. \_\_\_\_\_ is a unique feature of XL-U busway that results in a magnetic field cancellation.
4. To accommodate levels of current in the 3000 to 5000 ampere range, using aluminum XL-U busway, \_\_\_\_\_ bars per phase are used.
5. XJ-L is available in either \_\_\_\_\_ ampere or \_\_\_\_\_ ampere capacities.
6. The \_\_\_\_\_ is a bus plug available for XJ-L busway which provides 120 and 240 VAC.

# BD Busway

The BD™ busway is a general purpose power distribution busway of the plug-in design. BD busway is well established in the industry and has proven to be a dependable system. BD busway was first introduced in 1932, and with the exception of minor upgrades in materials, the basic design has remained unchanged. This means older systems can be expanded with today's BD busway components.

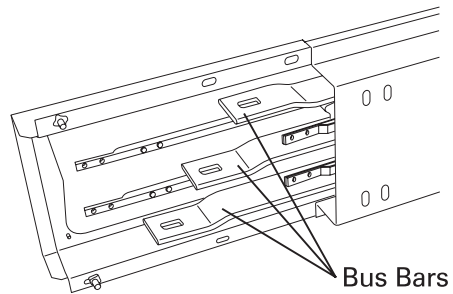

## Installation

The bus bars of one end of a section are offset and the other end is straight. To connect two sections together match an offset end with a straight end. When ordering new BD busway to expand an existing system it is important to note if the new connection will be to an existing offset or straight end.

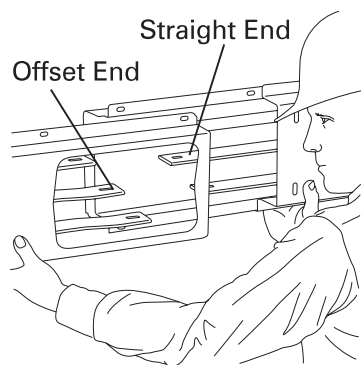

Bus bars are bolted together with a recommended 25 ft. lbs. of torque.

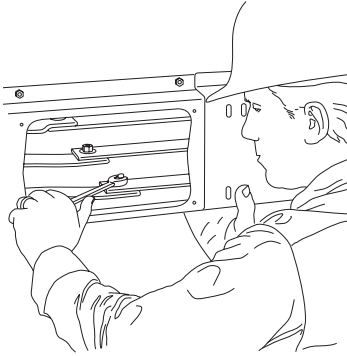

## Plug-ins

Each 10' section has ten bus plug receptacles, spaced alternately on each side (five on each side) of the busway section. Circuit breaker plugs are available in sizes from 100 to 800 amperes for voltages of 600 VAC or less. Fusible Vacu-Break<sup>®</sup> switch plugs are available in sizes of 30 to 600 amperes, 3-pole, 600 VAC or less, or 4-pole solid neutral, 240 or 480 VAC.

Capacitor and transformer bus plugs are also available. Capacitor bus plugs are used to reduce inductive heating and improving power factor. Transformer bus plugs furnish single-phase 120 or 240 VAC for lighting, small motors, or portable tools. Transformer plugs are also available with or without two-pole AC magnetic contactors for plugging in on three-phase 240 or 480 VAC.

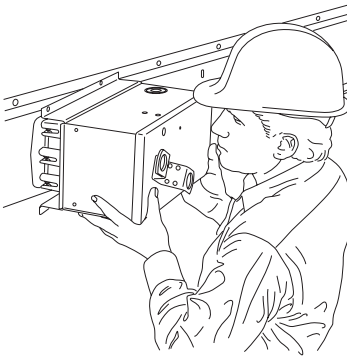

## Ratings and dimensions

BD busway comes in 10' lengths in current ratings from 225 to 1600 amperes. The number of bus bars per phase is determined by the current rating. A section of 225 amperes aluminum busway, for example, would have one bar per phase. A section of 1000 ampere aluminum busway would have two bus bars per phase. The following busway cross section diagram and table reflect ampere ratings and dimensions of BD busway.

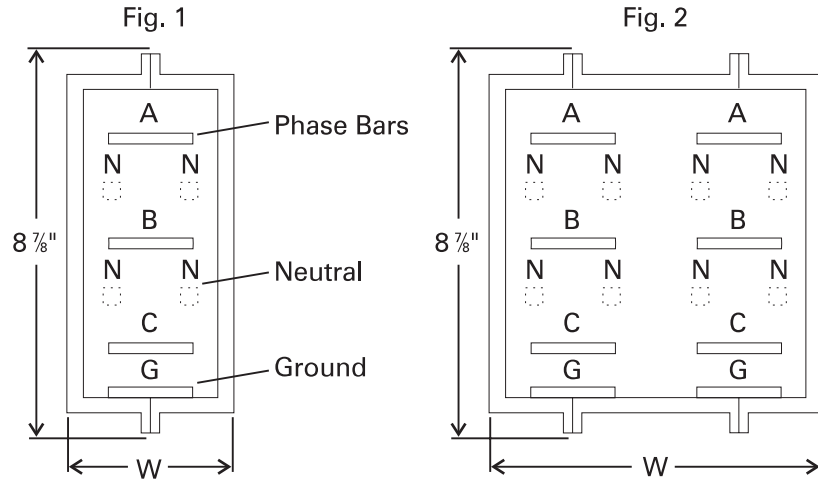

3Ø3W			3Ø4W - 100% Neutral		
Ampere Rating	Fig.#	Width (W)	Ampere Rating	Fig.#	Width (W)
<b>Aluminum</b>					
225	1	4 1/16"	225	1	4 1/16"
400	1	4 1/16"	400	1	4 1/16"
600	1	6 1/16"	600	1	6 1/16"
800	1	6 1/16"	800	1	8 1/8"
1000	2	12 1/8"	1000	2	12 1/8"
1200	2	12 1/8"	1200	2	12 1/8"
<b>Copper</b>					
225	1	4 1/16"	225	1	4 1/16"
400	1	4 1/16"	400	1	4 1/16"
600	1	4 1/16"	600	1	4 1/16"
800	1	6 1/16"	800	1	8 1/8"
1000	1	6 1/16"	1000	1	8 1/8"
1350	2	12 1/8"	—	—	—
1600	2	12 1/8"	—	—	—

## **Components**

The following components are available for BD busway:

- Hangers
- End closers
- Flanged ends
- Plug-in and center cable tap boxes
- Elbows
- Tees
- Crosses
- Bus plugs (circuit breaker, fusible)

# Trol-E-Duct

Trol-E-Duct™ is part of the Siemens busway family. This busway is designed to provide power to indoor moving equipment, such as cranes, conveyors, hoists, mobile tools, and similar moving equipment.

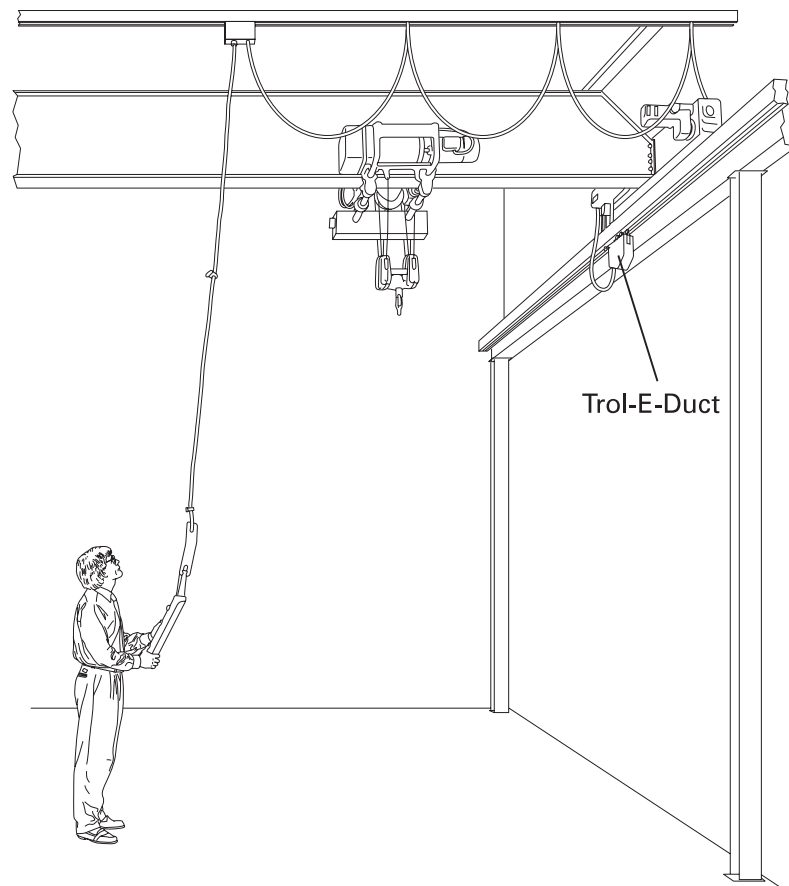

## Ratings

Trol-E-Duct is available in the following ratings:

Indoor  
1Ø2W, 1Ø3W, 3Ø3W, 3Ø4W  
100 to 800 amperes  
600 VAC

## Construction

Bus bars, inside a housing, provide power to a trolley. Brushes, mounted on the trolley, make contact with the bus bars. The trolley can be moved along an internal channel that is part of the housing. It may be desirable to have some sections of the busway that aren't powered. A section of the bus bar can be removed and replaced with a spacer that can be as small as  $\frac{1}{4}$ " or as large as 1'. It may be desirable to have a system that is powered only at specific locations. In these cases less expensive busless casings can be used throughout the unpowered sections.

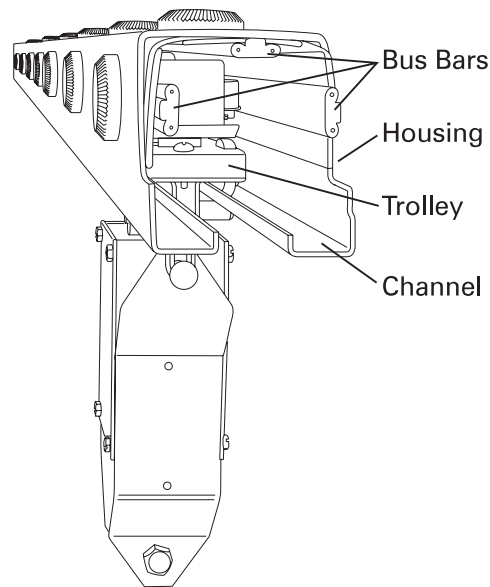

## Sections

Trol-E-Duct sections can be straight or curved. Curved sections are available only for 100 ampere busway. Curved sections can either be horizontal (shown) or vertical (not shown). Curved sections join with straight sections to create a continuous Trol-E-Duct system that matches any structural pattern. Curved sections are available for any radius of two feet or greater.

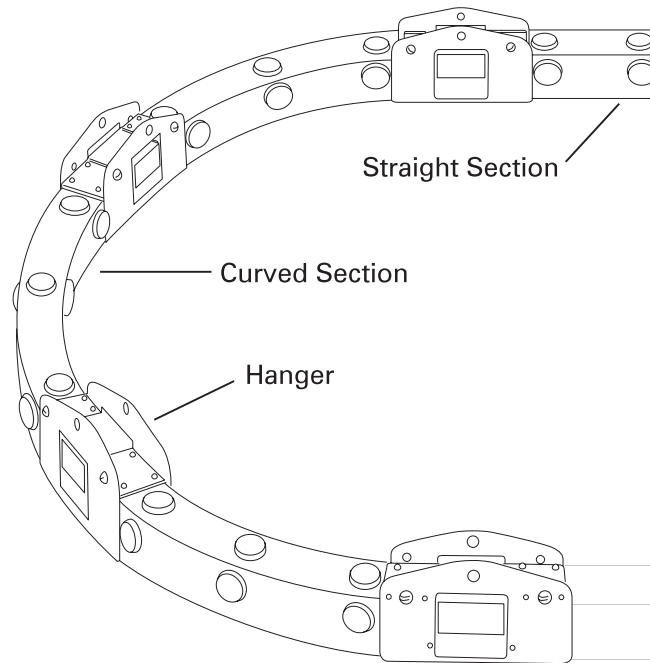

## Trolleys

Several types of trolleys are available for Trol-E-Duct. There are two types of tool hanger trolleys. Types TPTH and TBTH. Both types of tool hangers should not be used on a curved section with a radius of less than 5'. Type TPTH has provision for wiring a tool to the trolley. Type TBTH also has space for starters, receptacles and fuses.

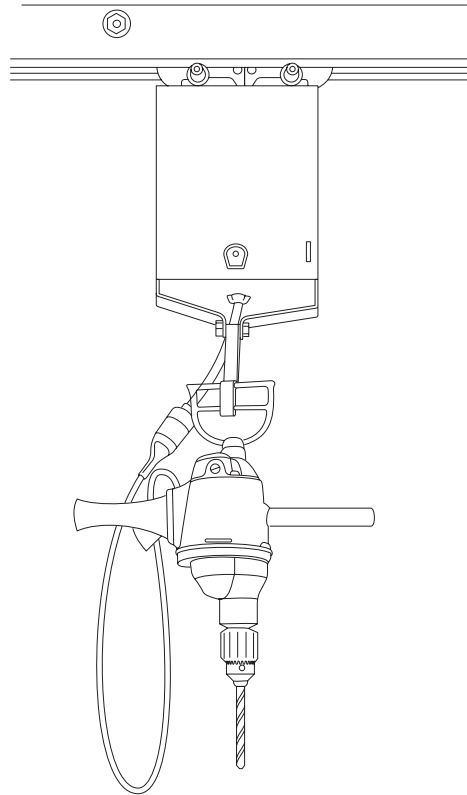

Several other types of trolleys are available for a wide variety of applications. In the following example a hoist is wired to a trolley. The hoist moves along a monorail that runs parallel to a Trol-E-Duct system.

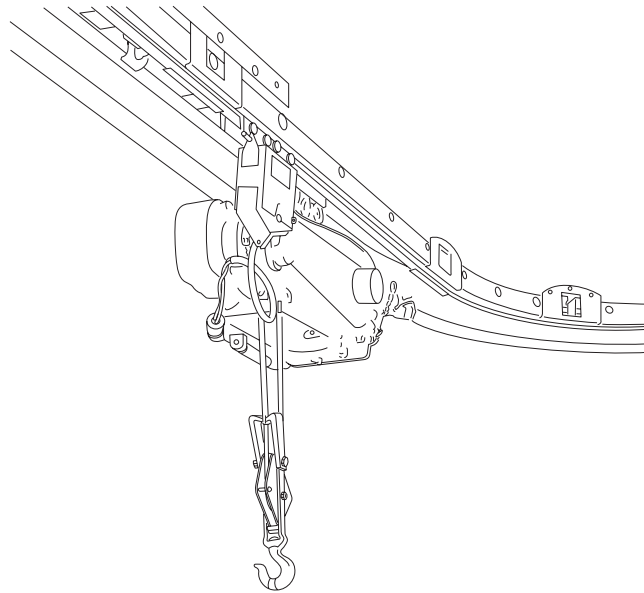

#### **Standard trolleys**

Standard trolleys are recommended for applications where the load current is less than 30 amperes, trolley speed is less than 5 m.p.h., and the curve radius is 5' or larger.

#### **Heavy-duty trolleys**

Heavy duty trolleys are used where the load current is less than 60 amperes, trolley speed is less than 5 m.p.h., and the curve radius is 5' or larger. By adding an additional pigtail between the brush and the wire grip the trolley can be rated as high as 90 amperes.

#### **Roller-type trolleys**

Roller-type trolleys are used on lighter duty applications. The load current is less than 20 amperes and the trolley speed does not exceed 2.5 m.p.h. Roller-type trolleys will negotiate a 5' radius curve.

#### **Curved-type trolleys**

Curved-type trolleys will negotiate a curve with a 3' radius or greater, speeds up to 5 m.p.h., and loads as high as 60 amperes.

#### **Button-type trolleys**

Button-type trolleys will negotiate a curve with a 5' radius or greater, speeds up to 5 m.p.h., and loads as high as 60 amperes. Extra wheels on this trolley make it well suited for carrying a heavy weight.

**Transfer trolley**

The transfer trolley is rated at 30 amperes and is suited for applications where the trolley must jump a gap in duct. Flared ends are used on the bus duct when the trolley must jump. The trolley can jump a separation as great as 3/8" with sections misaligned as much as 3/8". It will negotiate a curve with a radius of 2' or greater.

**Nylon brush trolley**

Nylon brush trolleys have brushes which are used to remove abrasive material, such as metallic or cement dust, from the bus bars.

**Abrasive trolley**

Abrasive trolleys are designed to clean and remove corrosive buildup from busbars in harsh atmospheres.

**Review 7**

1. BD busway was first introduced in \_\_\_\_\_ .
2. When ordering new BD busway to expand an existing system it is important to note if the new connection will be to an existing \_\_\_\_\_ or straight end.
3. Fusible Vacu-Break switches are available in sizes of \_\_\_\_\_ to \_\_\_\_\_ amperes for BD busway.
4. \_\_\_\_\_ is a type of busway that is designed to provide power to moving equipment such as cranes or hoists.
5. Standard Trol-E-Duct trolleys can handle a curve radius of \_\_\_\_\_ feet or larger.

# Review Answers

- Review 1** 1) distribution system; 2) feeder; 3) Busway; 4) busway; 5) feeder, plug-in; 6) Feeder, plug-in.
- Review 2** 1) two, three; 2) 47,000; 3) 66; 4) 364; 5) 200,000; 6) 10,000, 200,000.
- Review 3** 1) 4,000, 5,000; 2) a. feeder, b. plug-in; 3) 4', 6', 8'; 4) 2; 5) 0.125, 1, 10.
- Review 4** 1) C; 2) F; 3) A; 4) B; 5) E; 6) H; 7) G; 8) D.
- Review 5** 1) closed; 2) *Sentron Busway Systems Selection and Application Guide*; 3) 24, 24; 4) 5; 5) a.
- Review 6** 1) b; 2) 5000; 3) Paired phases; 4) eight; 5) 100, 200; 6) XQ-R.
- Review 7** 1) 1932; 2) offset; 3) 30, 600; 4) Trol-E-Duct; 5) 5.

# Final Exam

The final exam is intended to be a learning tool. The book may be used during the exam. A tear-out answer sheet is provided. A grade of 70% or better is passing. Upon successful completion of the test a certificate will be issued.

## Questions

1. The two types of busway are \_\_\_\_\_ .
  - a. feeder and service entrance
  - b. feeder and plug-in
  - c. plug-in and service entrance
  - d. indoor and outdoor
  
2. It typically takes \_\_\_\_\_ man-hours to install a busway system than cable and conduit.
  - a. about the same
  - b. more
  - c. fewer
  - d. twice as many
  
3. According to NEMA publication number BU 1-1995, the short-circuit rating of plug-in busway with a maximum continuous current rating of 1000 amperes should be at least \_\_\_\_\_ amperes.
  - a. 10,000
  - b. 14,000
  - c. 22,000
  - d. 42,000
  
4. According to IEC 529, a plug-in outlet that is said to be "finger safe" has an IEC code of IP \_\_\_\_\_ .
  - a. 2X
  - b. 40
  - c. 43
  - d. 54
  
5. General guidelines which discuss the safe application of busway are covered in the *National Electrical Code*<sup>®</sup> by Article \_\_\_\_\_ .
  - a. 364
  - b. 445
  - c. 365
  - d. 450



12. \_\_\_\_\_ are used to safely terminate a run of busway and protect the bus bar ends.
- a. End closers
  - b. Service heads
  - c. Tees
  - d. Flanged ends
13. When Sentron busway passes through a wall, a minimum distance of \_\_\_\_\_ from the wall to a joint where the new section of busway begins is required.
- a. 4"
  - b. 5"
  - c. 6"
  - d. 10"
14. The dimensions of a Sentron right elbow, with aluminum bus bars, rated for 1000 amperes is \_\_\_\_\_ .
- a. 10" x 10"
  - b. 12" x 12"
  - c. 18" x 18"
  - d. 24" x 24"
15. The paired-phase bus bar scheme is used with \_\_\_\_\_ busway.
- a. Sentron
  - b. XJ-L
  - c. XL-U
  - d. BD
16. The maximum current rating of XL-U busway with copper bus bars is \_\_\_\_\_ amperes.
- a. 3000
  - b. 4000
  - c. 5000
  - d. 6500
17. The maximum current rating of XJ-L busway is \_\_\_\_\_ amperes.
- a. 100
  - b. 5000
  - c. 200
  - d. 6000
18. The type of Siemens busway that was first introduced in 1932 is \_\_\_\_\_ busway.
- a. Sentron
  - b. XJ-L
  - c. XL-U
  - d. BD

19. \_\_\_\_\_ is the type of Trol-E-Duct tool box hanger that provides space for starters, receptacles and fuses.
- a. TBTH
  - b. TPTH
  - c. Transfer trolley
  - d. Button-type trolley
20. Curved sections of Trol-E-Duct are available for \_\_\_\_\_ .
- a. any radius of 2' or greater
  - b. a 2' radius only
  - c. any radius of 5' or greater
  - d. a 5' radius only

# Notes

# Notes