

Table of Contents

Introduction	2
Control Circuits	4
Electrical Symbols	6
Line Diagrams	16
Overload Protection	22
Overload Relays	26
Manual Control	34
Magnetic Contactors and Starters	41
Starter Ratings	46
Furnas INNOVA PLUS Starters	49
ESP100 Starters	50
Sirius Type 3R Starters	51
World Series Type 3TF Starters	53
Multi-Speed and Reversing Starters	55
Reduced-Voltage Starting	59
Pilot Devices	64
Control Transformers	75
Control Relays	76
Timing Relays	83
Limit Switches	88
Pressure Switches	92
Photoelectric Control	95
Inductive Proximity Switches	101
Capacitive Proximity Switches	106
Ultrasonic Sensors	109
LOGO! Logic Module	111
Review Answers	114
Final Exam	115

Introduction

Welcome to another course in the STEP 2000 series, **Siemens Technical Education Program**, designed to prepare our distributors to sell Siemens Energy & Automation products more effectively. This course covers **Basics of Control Components** and related products.

Upon completion of **Basics of Control Components** you will be able to:

- State the purpose and general principles of control components and circuits
- State the difference between manual and automatic control operation
- Identify various symbols which represent control components
- Read a basic line diagram
- Describe the construction and operating principles of manual starters
- Describe the construction and operating principles of magnetic contactors and magnetic motor starters
- Identify various Siemens and Furnas manual starters and magnetic motor starters, and describe their operation in a control circuit
- Explain the need for motor overload protection
- State the need for reduced-voltage motor starting
- Describe typical motor starting methods

- Describe the difference between normally open and normally pilot devices
- Describe the operating principles of control relays
- Describe how limit switches, photoelectric sensors, and proximity switches are used in control circuits

This knowledge will help you better understand customer applications. In addition, you will be better able to describe products to customers and determine important differences between products. You should complete **Basics of Electricity** before attempting **Basics of Control Components**. An understanding of many of the concepts covered in **Basics of Electricity** is required for **Basics of Control Components**.

If you are an employee of a Siemens Energy & Automation authorized distributor, fill out the final exam tear-out card and mail in the card. We will mail you a certificate of completion if you score a passing grade. Good luck with your efforts.

Siemens & Furnas Controls is a business unit of Siemens Energy & Automation, Inc.

BERO and SIMICONT are registered trademarks of Siemens Energy & Automation, Inc.

INNOVA PLUS and ESP100 are trademarks of Siemens Energy & Automation, Inc.

National Electrical Code[®] and NEC[®] are registered trademarks of the National Fire Protection Association, Quincy, MA 02269. Portions of the National Electrical Code are reprinted with permission from NFPA 70-1996, National Electrical Code Copyright, 1995, National Fire Protection Association, Quincy, MA 02269. This reprinted material is not the complete and official position of the National Fire Protection Association on the referenced subject which is represented by the standard in its entirety.

Underwriters Laboratories Inc. is a registered trademark of Underwriters Laboratories Inc., Northbrook, IL 60062. The abbreviation "UL" shall be understood to mean Underwriters Laboratories Inc.

CAGE CLAMP is a trademark of WAGO Corporation, Brown Deer, WI 53223

Control Circuits

The National Electrical Code® (NEC®) defines a controller as a *device or group of devices that serves to govern, in some predetermined manner, the electrical power delivered to the apparatus to which it is connected* (Article 100-definitions).

Control

Control, as applied to control circuits, is a broad term that means anything from a simple toggle switch to a complex system of components which may include relays, contactors, timers, switches, and indicating lights. Every electrical circuit for light or power has control elements. One example of a simple control circuit is a light switch used to turn lights on and off.

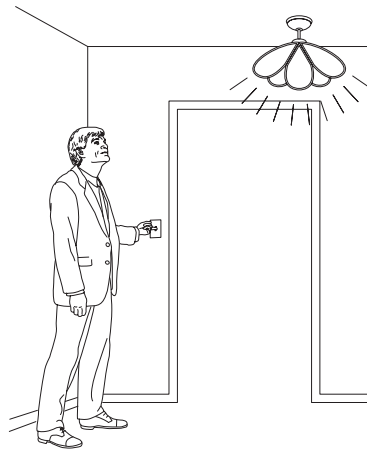

Of course there are many other devices and equipment systems in industrial applications. Motor control, for example, can be used to start and stop a motor and protect the motor, associated machinery, and personnel. In addition, motor controllers might also be used for reversing, changing speed, jogging, sequencing, and pilot-light indication. Control circuits can be complex: accomplishing high degrees of automatic and precise machine operation.

NEC® and National Electrical Code® are registered trademarks of the National Fire Protection Association. Reprinted with permission from NFPA 70-1996, the *National Electrical Code*®, Copyright® 1995, National Fire Protection Association, Quincy, MA 02269.

Manual Control

Control is considered to be manually operated when someone must initiate an action for the circuit to operate. For example, someone might have to flip the switch of a manual starter to start and stop a motor.

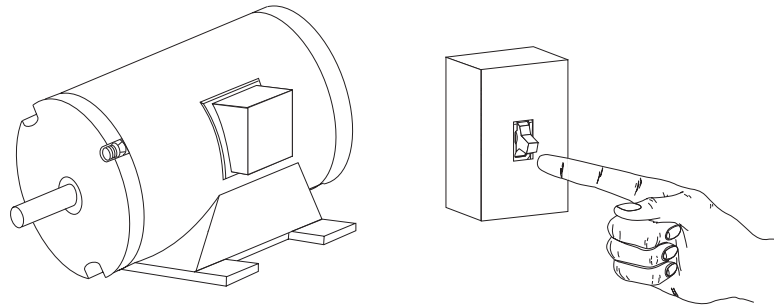

Automatic Operation

While manual operation of machines is still common practice, many machines are started and stopped automatically. Frequently there is a combination of manual and automatic control. A process may have to be started manually, but may be stopped automatically.

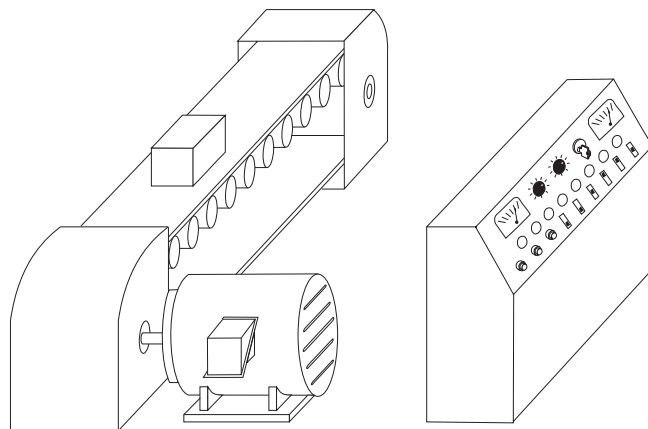

Control Elements

The elements of a control circuit include all of the equipment and devices concerned with the circuit function. This includes enclosures, conductors, relays, contactors, pilot devices, and overcurrent-protection devices. The selection of control equipment for a specific application requires a thorough understanding of controller operating characteristics and wiring layout. The proper control devices must be selected and integrated into the overall plan.

Note: Article 725, 240-5, and 430-71 to 430-74 in the *National Electrical Code*® covers the application of control circuits. You are encouraged to become familiar with this material.

Electrical Symbols

Language has been developed in order to transfer ideas and information. In order to understand the ideas and information being communicated, an understanding of the language is necessary. The language of controls consists of a commonly used set of symbols which represents control components.

Contact Symbols

Contact symbols are used to indicate an open or closed path of current flow. Contacts are shown as normally open (NO) or normally closed (NC). Contacts shown by this symbol require another device to actuate them.

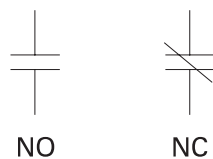

The standard method of showing a contact is by indicating the circuit condition it produces when the actuating device is in the deenergized or nonoperated state. For example, in the following illustration a relay is used as the actuating device. The contacts are shown as normally open, meaning the contacts are open when the relay is deenergized. A complete path of current does not exist and the light is off.

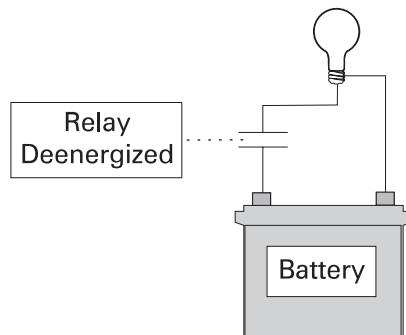

Normally Open Contact Example

In a control diagram or schematic, symbols are usually not shown in the energized or operated state. For the purposes of explanation in this text, a contact or device shown in a state opposite of its normal state will be highlighted. For example, in the following illustration the circuit is first shown in the deenergized state. The contacts are shown in their normally open (NO) state. When the relay is energized, the contacts close completing the path of current and illuminating the light. The contacts have been highlighted to indicate they are now closed. This is not a legitimate symbol. It is used here for illustrative purposes only.

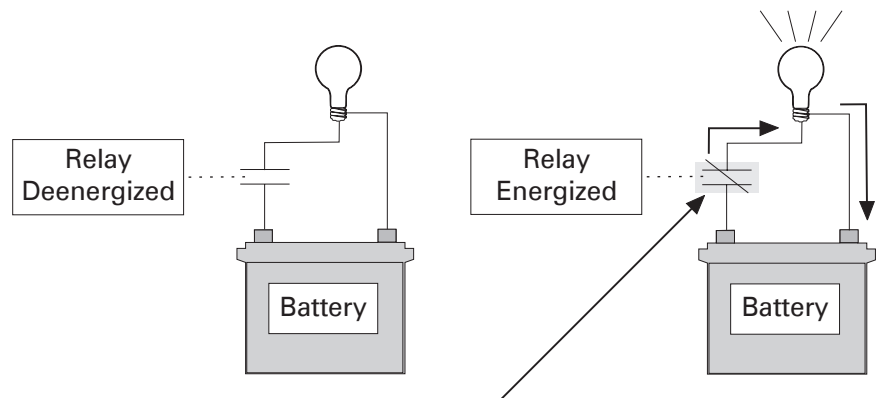

Contacts are shown opposite of their normal state (NO).

Normally Closed Contact Example

In the following illustration the contacts are shown as normally closed (NC), meaning the contacts are closed when the relay is deenergized. A complete path of current exists and the light is on. When the relay is energized, the contacts open turning the light off.

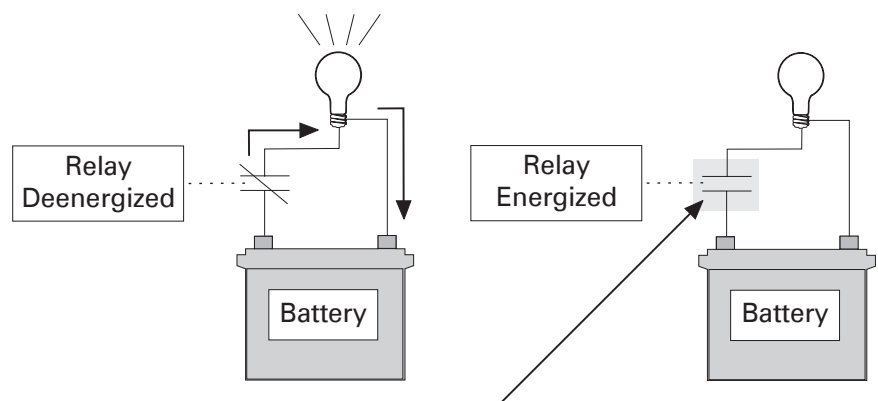

Contacts are shown opposite of their normal state (NC).

Switch Symbols

Switch symbols are also used to indicate an open or closed path of current flow. Variations of this symbol are used to represent limit switches, foot switches, pressure switches, level switches, temperature-actuated switches, flow switches, and selector switches. Switches, like contacts, require another device or action to change their state. In the case of a manual switch someone must manually change the position of the switch.

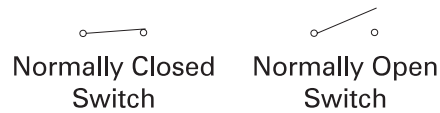

Normally Open Switch Example

In the following illustration a battery is connected to one side of a normally open switch and a light to the other. Current is prevented from flowing to the light when the switch is open. When someone closes the switch, the path of current flow is completed and the light illuminates.

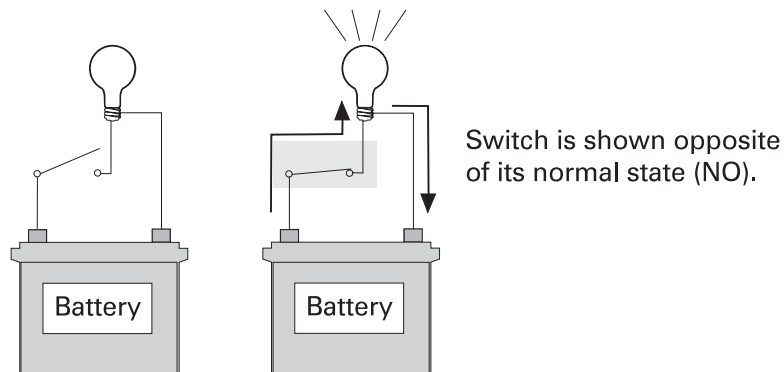

Normally Closed Switch Example

In the following illustration a battery is connected to one side of a normally closed switch and a light to the other. Current is flowing to the light when the switch is closed. When someone opens the switch, the path of current flow is interrupted and the light turns off.

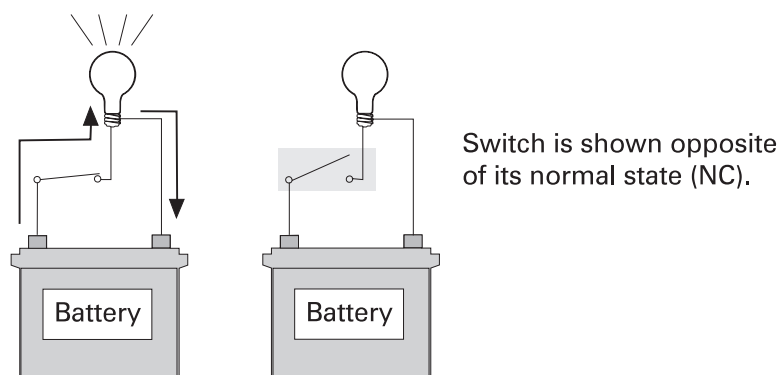

Pushbutton Symbols

There are two basic types of pushbuttons: momentary and maintained. A normally open momentary pushbutton closes as long as the button is held down. A normally closed momentary pushbutton opens as long as the button is held down. A maintained pushbutton latches in place when the button is pressed.

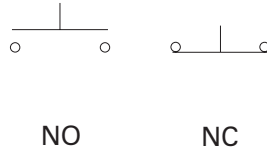

Normally Open Pushbutton Example

In the following illustration a battery is connected to one side of a normally open pushbutton and a light is connected to the other side. When the pushbutton is depressed, a complete path of current flow exists through the pushbutton and the light is illuminated.

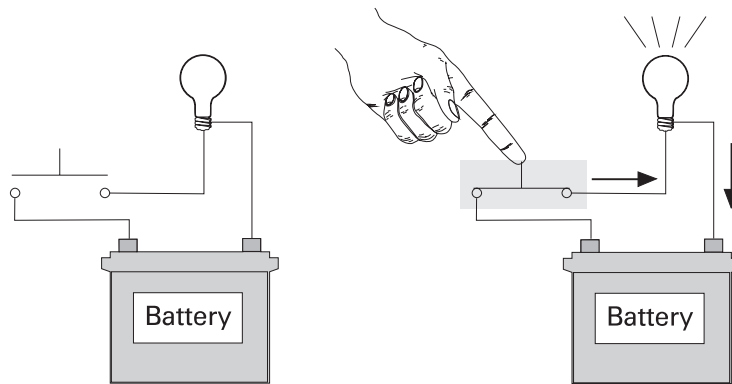

Normally Closed Pushbutton Example

In the following example current will flow to the light as long as the pushbutton is not depressed. When the pushbutton is depressed, current flow is interrupted and the light turns off.

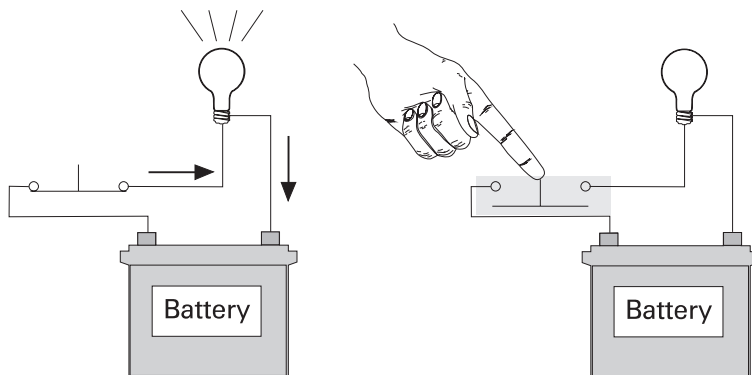

Coil Symbols

Coils are used in electromagnetic starters, contactors, and relays. The purpose of contactors and relays is to open and close associated contacts. A letter is used to designate the coil; for example, "M" frequently indicates a motor starter and "CR" indicates a control relay. The associated contacts have the same identifying letter. Contactors and relays use an electromagnetic action which will be described later to open and close these contacts. The associated contacts can be either normally open or normally closed.

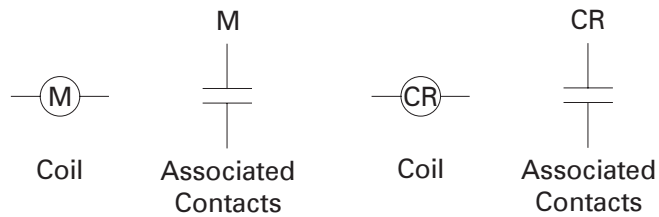

Coil Example Using Normally Open Contacts

In the following example, the "M" contacts in series with the motor are controlled by the "M" contactor coil. When someone closes the switch, a complete path of current flow exists through the switch and "M" contactor coil. The "M" contactor coil actuates the "M" contacts which provide power to the motor.

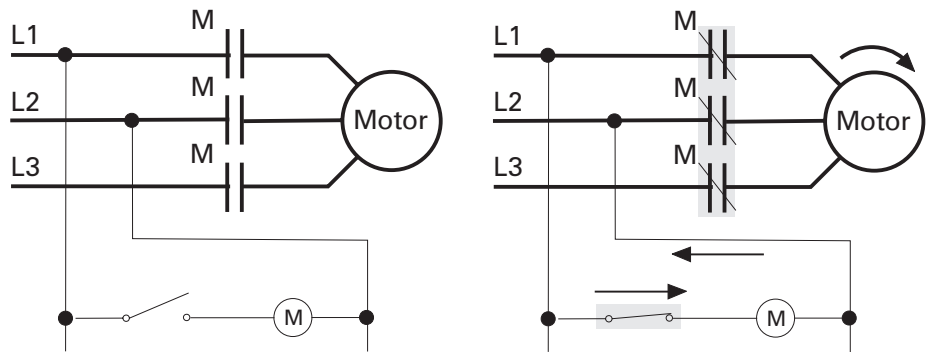

Overload Relay Symbols

Overload relays are used to protect motors from overheating due to an overload on the driven machinery, low-line voltage, or an open phase in a three-phase system. When excessive current is drawn for a predetermined amount of time, the relay opens and the motor is disconnected from its source of power.



Thermal
Overload

Pilot Light Symbols

A pilot light is a small electric light used to indicate a specific condition of a circuit. For example, a red light might be used to indicate a motor is running. The letter in the center of the pilot light symbol indicates the color of the light.

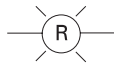

Red
Pilot Light

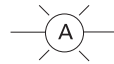

Amber
Pilot Light

Other Symbols

In addition to the symbols discussed here, there are many other symbols used in control circuits. The following chart shows many of the commonly used symbols.

AC Motors		
Single Phase	Three-Phase Squirrel Cage	Wound Rotor

DC Motors			
Armature	Shunt Field	Series Field	Comm. or Compens. Field
	 (Show 4 Loops)	 (Show 3 Loops)	 (Show 2 Loops)

Schematic Wiring			
Not Connected	Connected	Power	Control

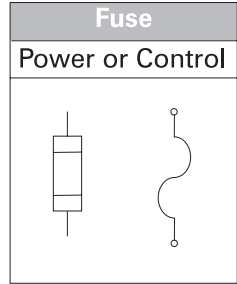
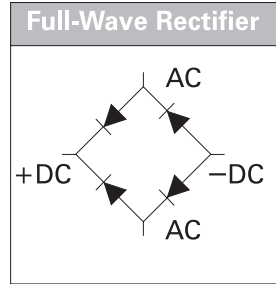
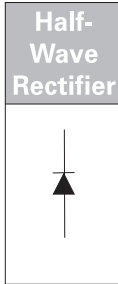
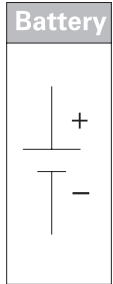

Annunciator	Bell	Buzzer	Horn, Siren, Etc.

Meter
Indicate Type by Letter

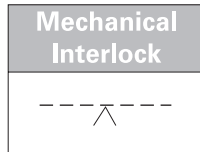
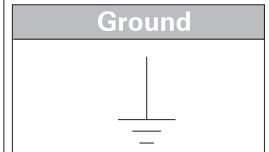
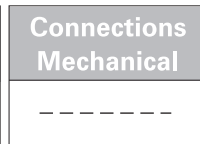
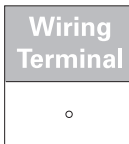
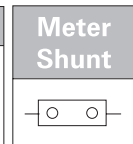



Resistors			
Fixed	Heating Element	Adj. By Fixed Taps	Rheostat Pot Or Adj. Tap

Capacitors	
Fixed	Adjustable

Supplementary Contact Symbols					
SPST NO		SPST NC		SPDT	
Single Break	Double Break	Single Break	Double Break	Single Break	Double Break
DPST 2 NO		DPST 2 NC		DPDT	
Single Break	Double Break	Single Break	Double Break	Single Break	Double Break

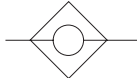
Terms	
SPST	Single-Pole Single-Throw
SPDT	Single-Pole Double-Throw
DPST	Double-Pole Single-Throw
DPDT	Double-Pole Double-Throw
NO	Normally Open
NC	Normally Closed

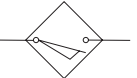
Symbols For Static Switching Control Devices		
<p>Static switching control is a method of switching electrical circuits without the use of contacts. Primarily by solid-state devices. Use the symbols shown in the table on the previous page except enclosed in a diamond.</p> <p>Examples:</p>		
Input "Coil"	Output (NO)	Limit Switch (NO)
		

Control and Power Connections - 600 Volts or Less - Across-the-Line Starters (From NEMA Standard ICS 2-321A.60)			
	1 Phase	2 Phase 4 Wire	3 Phase
Line Markings	L1,L2	L1,L3-Phase 1 L2,L4-Phase 2	L1,L2,L3
Ground When Used	L1 is always Ungrounded	—	L2
Motor Running Overcurrent Units In	1 Element L1 2 Element — 3 Element —	— L1,L4 —	— — L1,L2,L3
Control Circuit Connected To	L1,L2	L1,L3	L1,L2
For Reversing Interchange Lines	—	L1,L3	L1,L3

Abbreviations

Abbreviations are frequently used in control circuits. The following list identifies a few commonly used abbreviations.

AC	Alternating Current	M	Motor Starter
ALM	Alarm	MTR	Motor
AM	Ammeter	MN	Manual
ARM	Armature	NEG	Negative
AU	Automatic	NEUT	Neutral
BAT	Battery	NC	Normally Closed
BR	Brake Relay	NO	Normally Open
CAP	Capacitor	OHM	Ohmmeter
CB	Circuit Breaker	OL	Overload
CKT	Circuit	PB	Pushbutton
CONT	Control	PH	Phase
CR	Control Relay	POS	Positive
CT	Current Transformer	PRI	Primary
D	Down	PS	Pressure Switch
DC	Direct Current	R	Reverse
DISC	Disconnect Switch	REC	Rectifier
DP	Double-Pole	RES	Resistor
DPDT	Double-Pole, Double-Throw	RH	Rheostat
DPST	Double-Pole, Single-Throw	S	Switch
DT	Double-Throw	SEC	Secondary
F	Forward	SOL	Solenoid
FREQ	Frequency	SP	Single-Pole
FTS	Foot Switch	SPDT	Single-Pole, Double-Throw
FU	Fuse	SPST	Single-Pole, Single-Throw
GEN	Generator	SS	Selector Switch
GRD	Ground	SSW	Safety Switch
HOA	Hand/Off/Auto Selector Switch	T	Transformer
IC	Integrated Circuit	TB	Terminal Board
INTLK	Interlock	TD	Time Delay
IOL	Instantaneous Overload	THS	Thermostat Switch
JB	Junction Box	TR	Time Delay Relay
LS	Limit Switch	U	Up
LT	Lamp	UV	Under Voltage
		VFD	Variable Frequency Drive
		XFR	Transformer

Review 1

1. A control is _____ operated when someone must initiate an action for the circuit to operate.
2. Which of the following symbols represents a normally open contact?

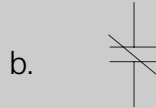
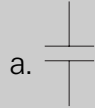

3. Which of the following symbols represents a normally closed contact?

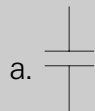

4. Which of the following symbols indicates a normally open pushbutton?

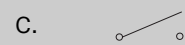
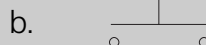
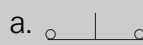

5. Which of the following symbols indicates a mushroom head pushbutton?

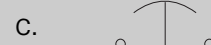
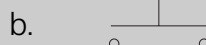
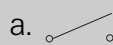

Line Diagrams

The method of expressing the language of control symbols is a line diagram, also referred to as a ladder diagram. Line diagrams are made up of two circuits, the control circuit and the power circuit. Electrical wires in a line diagram are represented by lines. Control-circuit wiring is represented by a lighter-weight line and power-circuit wiring is represented by a heavier-weight line. A small dot or node at the intersection of two or more wires indicates an electrical connection.

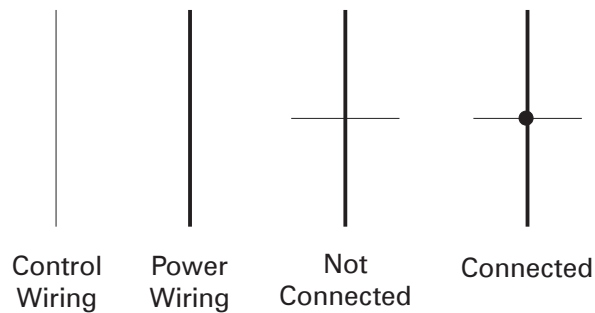

Line diagrams show the functional relationship of components and devices in an electrical circuit, not the physical relationship. For example, the following illustration shows the physical relationship of a pilot light and a pushbutton.

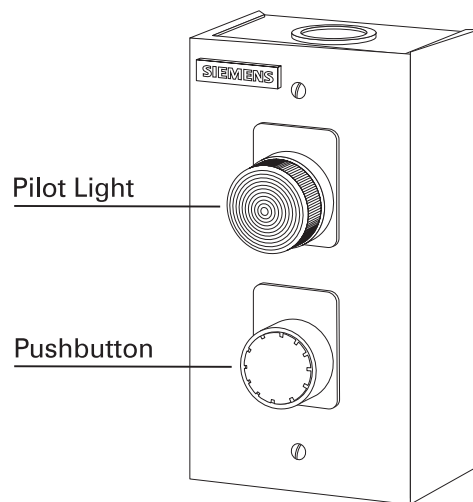

The functional relationship can be shown pictorially with the following illustration.

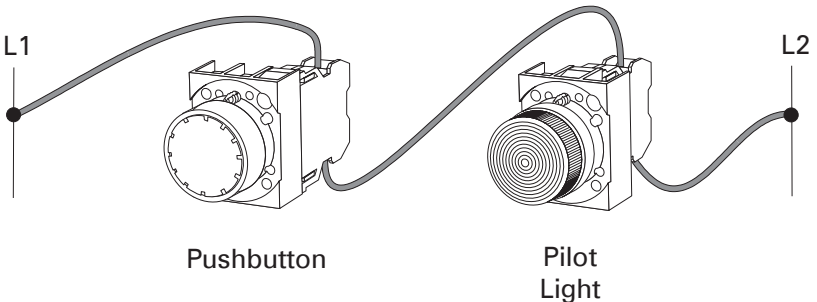

Reading a Line Diagram

This functional relationship is shown symbolically with a line diagram. Line diagrams are read from left to right. Depressing the pushbutton would allow current to flow from L1 through the pushbutton, illuminating the pilot light, to L2. Releasing the pushbutton stops current flow turning the pilot light off.

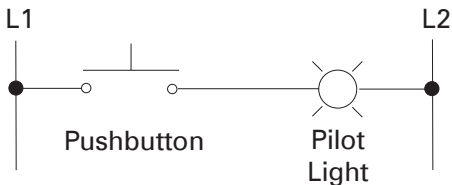

Power Circuit and Control Circuit

The power circuit, indicated by the heavier-weight line, is what actually distributes power from the source to the connected load (motor). The control circuit, indicated by the lighter-weight line, is used to “control” the distribution of power.

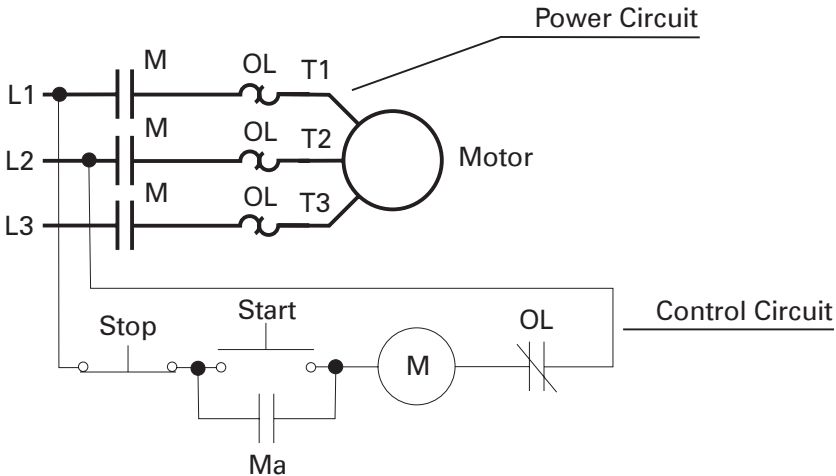

Connecting Loads and Control Devices

Control circuits are made up of control loads and control devices. The control load is an electrical device that uses electrical power. Pilot lights, relays, and contactors are examples of control loads. Control devices are used to activate the control load. Pushbuttons and switches are examples of control devices. The following illustration shows the proper connection of a pilot light (load) with a pushbutton (control device). The power lines are drawn vertically and marked L1 and L2. In this example the voltage potential between L1 and L2 is 120 VAC. The pilot light selected must be rated for 120 VAC. When the pushbutton is depressed, the full 120 volt potential is applied to the pilot light.

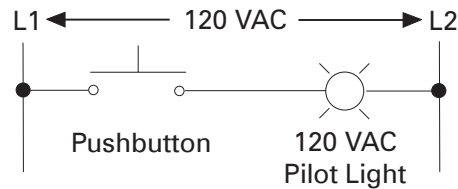

Connecting the Load to L2

Only one control load should be placed in any one circuit line between L1 and L2. One side of the control load is connected to L2 either directly or, in some instances, through overload relay contacts. In the following example a pilot light is directly connected to L2 on one circuit line. A contactor coil is indirectly connected through a set of overload contacts (OL) to L2 on a second circuit line. This is a parallel connection. Depressing the pushbutton would apply 120 VAC to the pilot light and the "M" contactor.

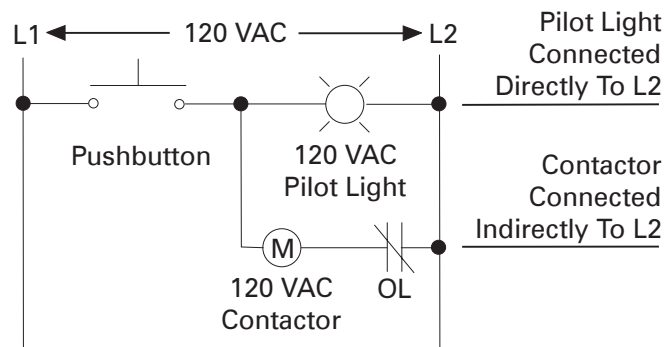

Control loads are generally not connected in series. The following illustration shows two ways to connect a control load. In one instance the control loads are improperly connected in series. When the pushbutton is depressed, the voltage across L1 and L2 is divided across both loads, the result being that neither load will receive the full 120 volts necessary for proper operation. If one load fails in this configuration, the entire circuit is rendered useless.

In the other instance the loads are properly connected in parallel. In this circuit there is only one load for each line between L1 and L2. The full 120 volts will appear across each load when the pushbutton is depressed. If one load fails in this configuration, the other load will continue to operate normally.

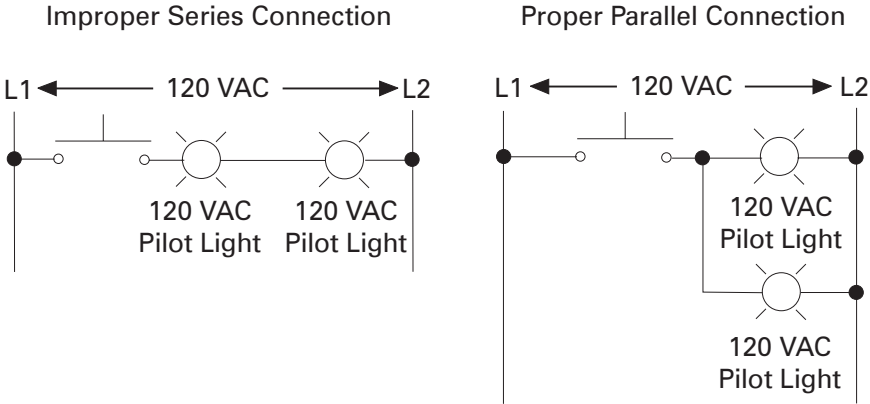

Connecting Control Devices

Control devices are connected between L1 and the load. The control device can be connected in series or parallel, depending on the desired results. In the following illustration, the pushbuttons are connected in parallel. Depressing either pushbutton will allow current to flow from L1, through the depressed pushbutton, through the pilot light, to L2.

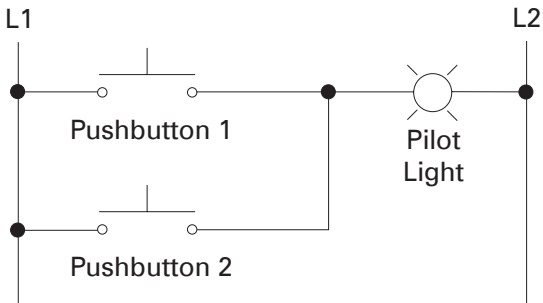

In the following illustration, two pushbuttons are connected in series. Both pushbuttons must be depressed in order to allow current to flow from L1 through the load to L2.

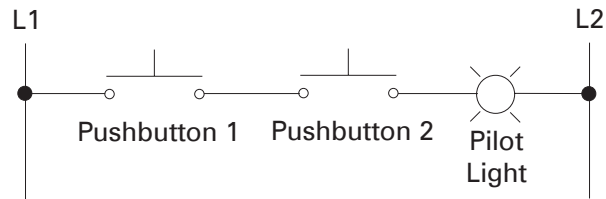

Line Numbering

Numbering each line makes it easier to understand more complex line diagrams. In the following illustration, line 1 connects pushbutton 1 to pilot light 1. Line 2 connects pushbutton 2 to pilot light 1. Line 3 connects switch 1 to pilot light 2 and the "M" contactor on line 4.

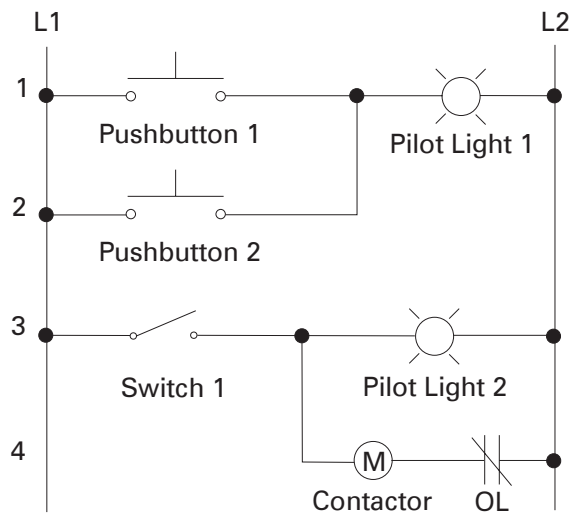

Review 2

1. Line diagrams are read from _____ to _____, or L1 to L2.
2. Match the items on the line diagram with the associated list.

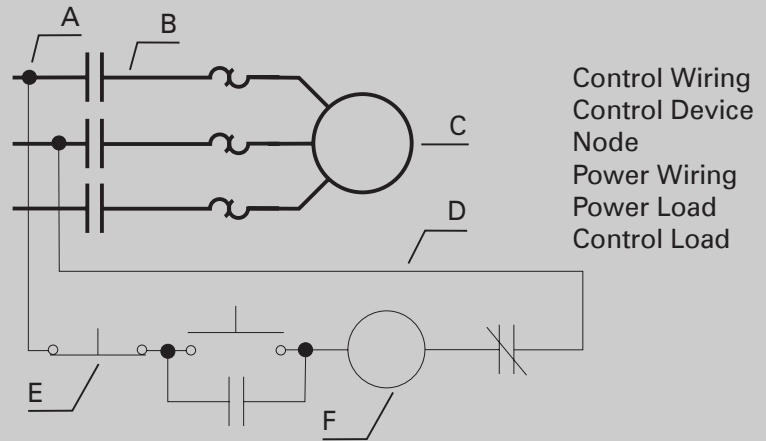

A _____

B _____

C _____

D _____

E _____

F _____

Overload Protection

Before discussing specific control components, it is necessary to review what an overload is and what steps can be taken to limit the damage an overload can cause.

Current and Temperature

Current flow in a conductor always generates heat due to resistance. The greater the current flow, the hotter the conductor. Excess heat is damaging to electrical components. For that reason, conductors have a rated continuous current carrying capacity or ampacity. Overcurrent protection devices are used to protect conductors from excessive current flow. Thermal overload relays are designed to protect the conductors (windings) in a motor. These protective devices are designed to keep the flow of current in a circuit at a safe level to prevent the circuit conductors from overheating.

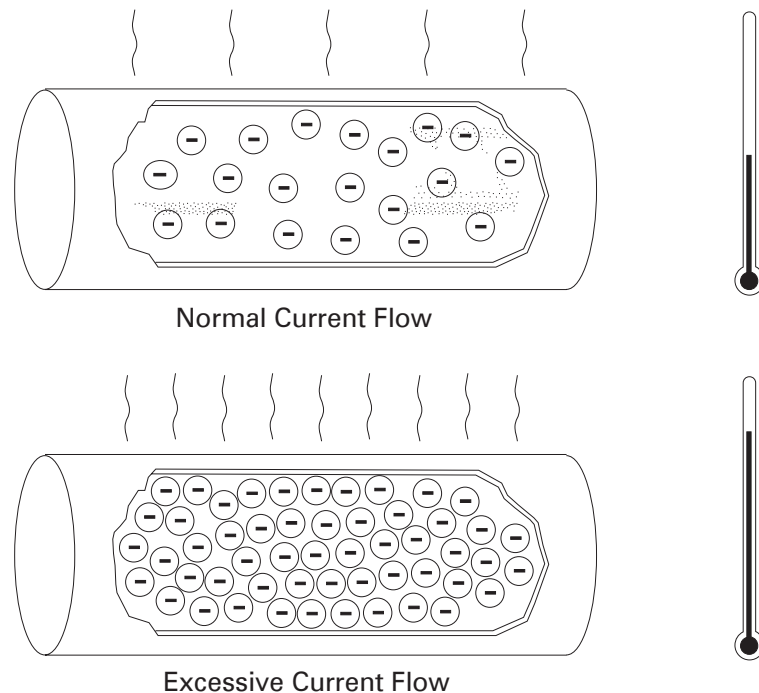

Excessive current is referred to as overcurrent. The *National Electrical Code*® defines overcurrent as *any current in excess of the rated current of equipment or the ampacity of a conductor. It may result from overload, short circuit, or ground fault* (Article 100-definitions).

Short Circuits

When two bare conductors touch, a short circuit occurs. When a short circuit occurs, resistance drops to almost zero. Short-circuit current can be thousands of times higher than normal operating current.

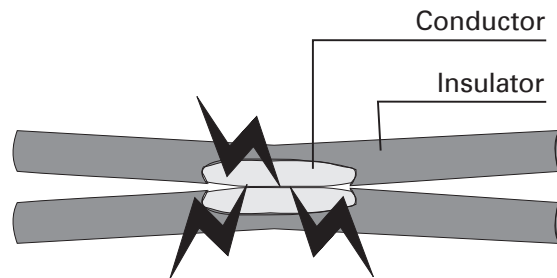

Ohm's Law demonstrates the relationship of current, voltage, and resistance. For example, a 240 volt motor with 24 W of resistance would normally draw 10 amps of current.

$$I = \frac{E}{R}$$
$$I = \frac{240}{24}$$
$$I = 10 \text{ amps}$$

When a short circuit develops, resistance drops. If resistance drops to 24 milliohms, current will be 10,000 amps.

$$I = \frac{240}{.024}$$
$$I = 10,000 \text{ amps}$$

The heat generated by this current will cause extensive damage to connected equipment and conductors. This dangerous current must be interrupted immediately when a short circuit occurs.

Overload Protection

Fuses and circuit breakers are protective devices used to protect circuits against short circuits, ground faults, and overloads. In the event of a short circuit, a properly sized fuse or circuit breaker will immediately open the circuit.

There is, however, a dilemma that occurs when applying fuses and circuit breakers in motor control circuits. The protective device must be capable of allowing the motor to exceed its full-load rating for a short time. Otherwise, the motor will trip each time it is started. In this situation it is possible for a motor to encounter an overload condition which does not draw enough current to open the fuse or trip the circuit breaker. This overload condition could easily cause enough heat to damage the motor. In the next section we will see how overload relays are used to solve this problem.

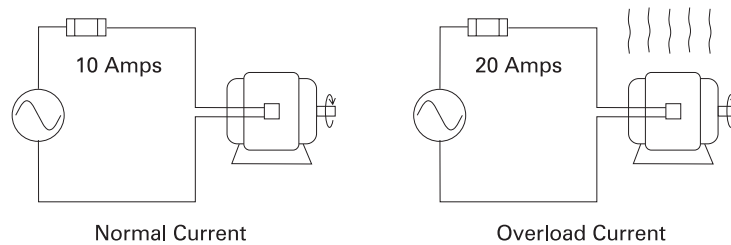

Overload Relays

Overload relays are designed to meet the special protective needs of motor control circuits. Overload relays:

- allow harmless temporary overloads, such as motor starting, without disrupting the circuit
- will trip and open a circuit if current is high enough to cause motor damage over a period of time
- can be reset once the overload is removed

Trip Class

Overload relays are rated by a trip class, which defines the length of time it will take for the relay to trip in an overload condition. The most common trip classes are Class 10, Class 20 and Class 30. Class 10, for example, has to trip the motor off line in 10 seconds or less at 600% of the full load amps. This is usually sufficient time for the motor to reach full speed. Many industrial loads, particularly high inertia loads, use Class 30. Siemens standard overload relays are Class 10 or Class 20 with Class 30 available with some starters.

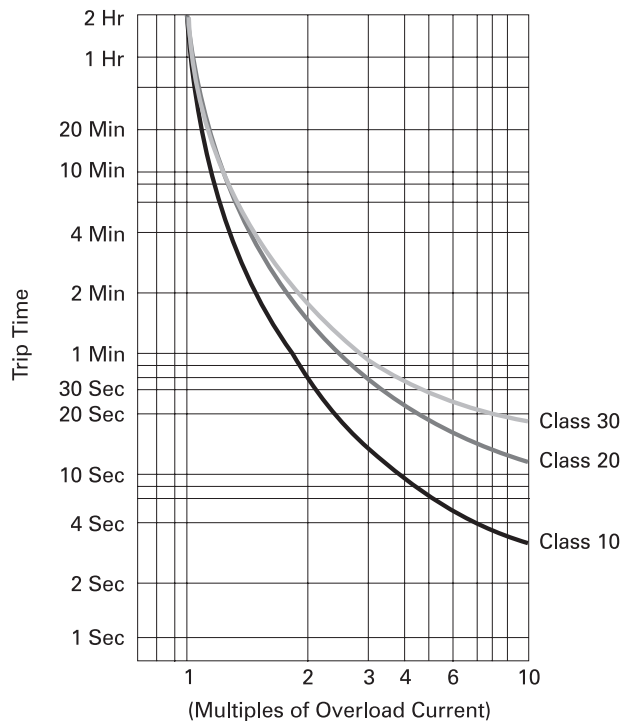

Overload Relay in a Motor Circuit

The following schematics show a motor circuit with a manual starter and overloads. Current flows through the overloads while the motor is running. Excess current will cause the overload to trip at a predetermined level, opening the circuit between the power source and the motor. After a predetermined amount of time the starter can be reset. When the cause of the overload has been identified and corrected the motor can be restarted.

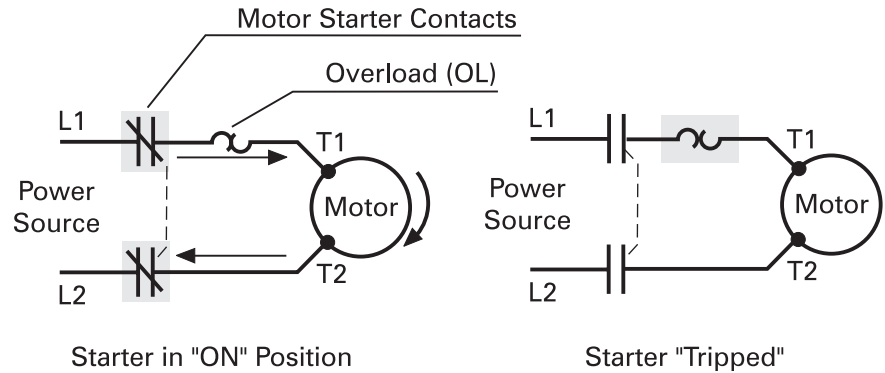

Melting Alloy

One method of providing overload protection is with a melting alloy overload relay. The alloy is a solder which melts at a very precise temperature. When it reaches this specific temperature it will change from its solid state to a liquid state. This temperature never changes, ensuring the accuracy of the overload during the life of the relay.

The overload relay is connected in series between the line and the motor. Current flows from L1 through a normally closed (NC) contact and a heater element to the motor. During normal operation the melting alloy is solid and holds the ratchet wheel firmly in place. The contacts are held closed by a pawl that is connected to the ratchet wheel.

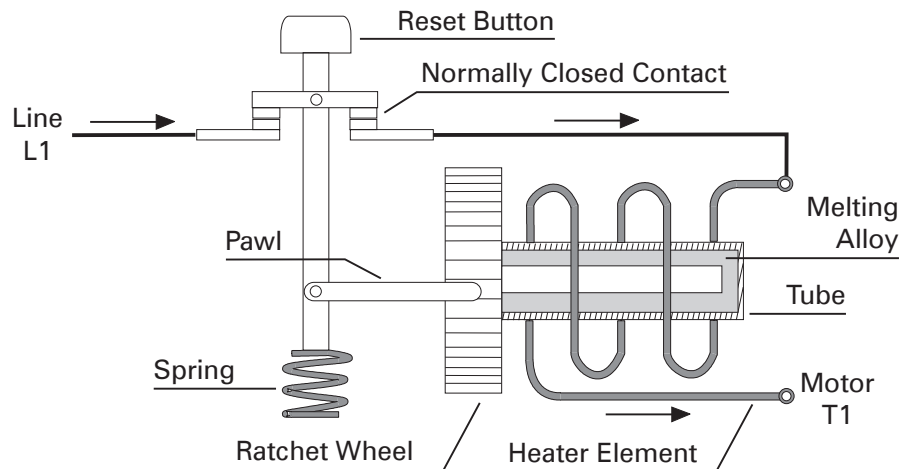

If an overload occurs, the current flow through the heater element is sufficient to cause the melting alloy to melt. The ratchet wheel is free to turn. Spring tension pushes the reset button up, opening the normally closed contacts and stopping the motor. Current no longer flows through the heater element allowing the melting alloy to solidify. Once the melting alloy has become solid, the contacts can be closed by manually depressing the reset button, forcing the pawl across the ratchet wheel until the contacts are closed and the spring and ratchet wheel are returned to the original condition. The start button can then be pressed to restart the motor.

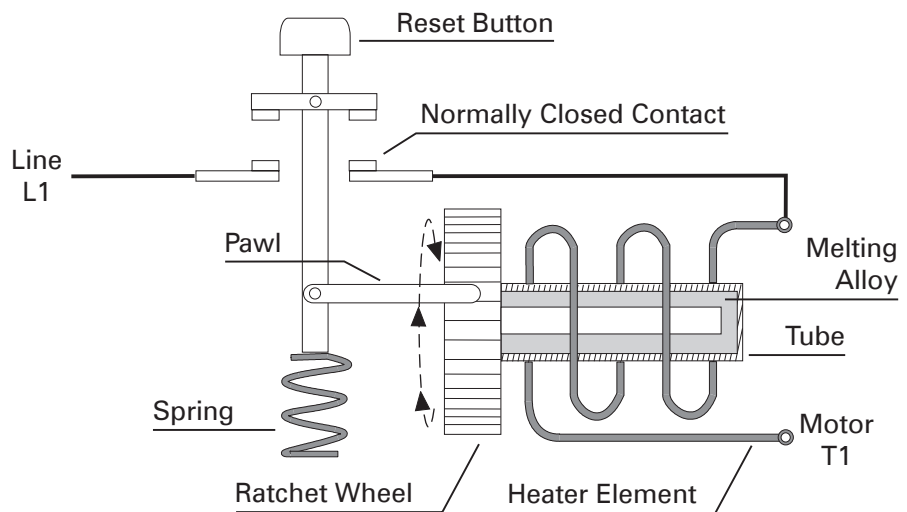

Class 48 Melting Alloy Overload Relay

The Furnas Class 48 melting alloy overload relay is available in single-pole or three-pole configurations. This type of relay requires heater elements and comes with a Class 20 trip rating. The melting alloy overload relay must be manually reset. As an option, for the three-pole configuration, an isolated normally open or a normally closed auxiliary contact is available.

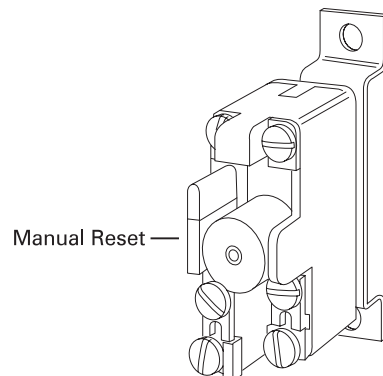

Bimetal Overloads

Another type of overload relay is the bimetal overload relay. Overload protection is accomplished with the use of a bimetal strip. This component consists of a small heater element wired in series with the motor and a bimetal strip that can be used as a trip lever. A bimetal strip is made of two dissimilar metals bonded together. The two metals have different thermal expansion characteristics, so the bimetal bends at a given rate when heated.

Under normal operating conditions the heat generated by the heater element will be insufficient to cause the bimetal strip to bend enough to trip the overload relay. As current rises, heat also rises. The hotter the bimetal becomes, the more it bends. In an overload condition the heat generated from the heater will cause the bimetal strip to bend until the mechanism is tripped, stopping the motor.

Some overload relays that are equipped with a bimetal strip are designed to automatically reset the circuit when the bimetal strip has cooled and reshaped itself, restarting the motor. If the cause of the overload still exists, the motor will trip again and reset at given intervals. Care must be exercised in the selection of this type of overload as repeated cycling will eventually damage the motor.

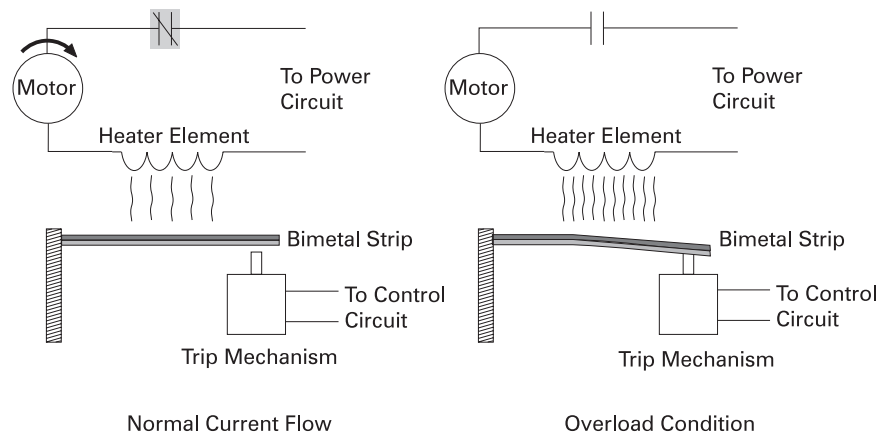

Ambient Compensated Overload Relay

In certain applications, such as a submersible pump, the motor may be installed in a location having a constant ambient temperature. The motor control, along with the overload relay, may be installed in a location with a varying ambient temperature. The trip point of the overload relay will vary with the temperature of the surrounding air as well as current flowing through the motor. This can lead to premature and nuisance tripping.

Ambient compensated overload relays are designed to overcome this problem. A compensated bimetal strip is used along with a primary bimetal strip. As the ambient temperature changes, both bimetal strips will bend equally and the overload relay will not trip the motor. However, current flow through the motor and the heater element will affect the primary bimetal strip. In the event of an overload condition the primary bimetal strip will engage the trip unit.

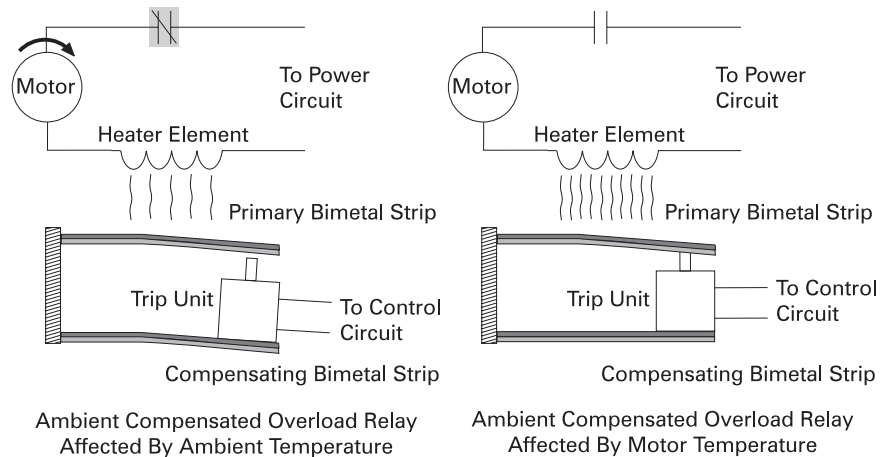

|

Class 48 Bimetal Overload Relay

The Class 48 bimetal overload relay is available in single-pole or three-pole designs. Like the melting alloy overload relay, this overload relay requires separate heaters. Unlike the melting alloy overload relay, the bimetal overload relay can be set for manual or self-resetting operation. An adjustment dial located on the unit allows the ampere trip setting to be adjusted by $\pm 15\%$. The bimetal overload relay heater elements are available in Class 20 or Class 10 ratings. Ambient compensated overload relays are also available. A normally open or normally closed auxiliary contact is available as an option.

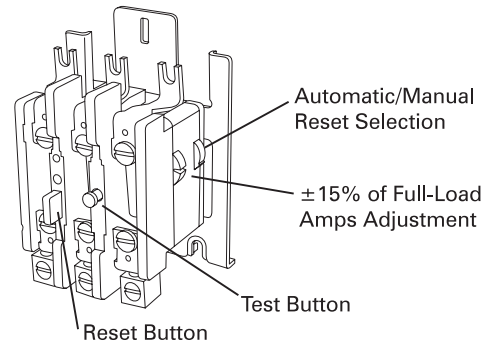

Sirius 3RU11 Overload Relay

The Siemens Sirius 3RU11 is a bimetal type of overload relay with the heater elements as an integral part of the design. The unit comes with a Class 10 trip as standard. The Sirius 3RU11 features manual or automatic reset, adjustable current settings, and ambient compensation. A switch-position indicator also incorporates a test function which is used to simulate a tripped overload relay. A normally open and a normally closed auxiliary contact are included.

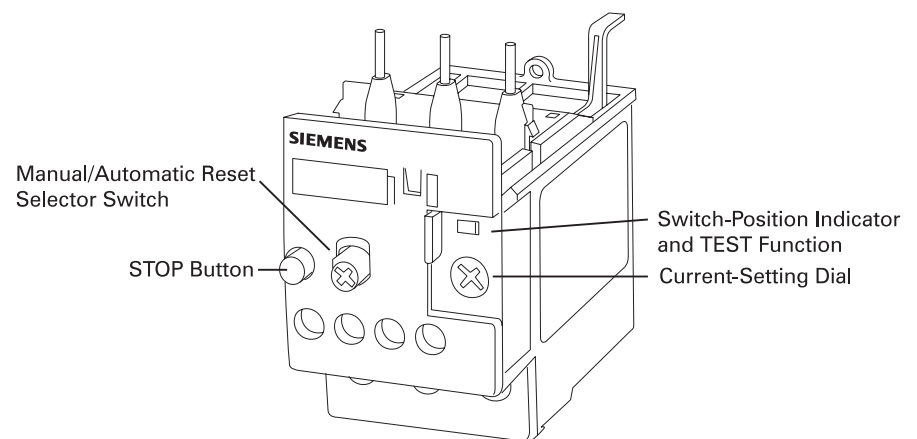

Electronic Overload Relays

Electronic overload relays are another option for motor protection. The features and benefits of electronic overload relays vary but there are a few common traits. One advantage offered by electronic overload relays is a heaterless design. This reduces installation cost and the need to stock a variety of heaters to match motor ratings. Electronic relays offer phase loss protection. If a power phase is lost, motor windings can burn out very quickly. Electronic overload relays can detect a phase loss and disconnect the motor from the power source. This feature is not available on mechanical types of overload relays.

Furnas ESP 100 Electronic Overload Relay

A single ESP100 overload relay replaces at least six size ranges of heaters. Instead of installing heaters the full-load amperes (FLA) of the motor is set with a dial. The ESP100 overload relay illustrated below, for example, is adjustable from 9 to 18 amperes. NEMA Class 10, 20, and 30 trip curves are available for a variety of applications. The relay comes in either a manual or self-resetting version. Auxiliary contacts are available as an option.

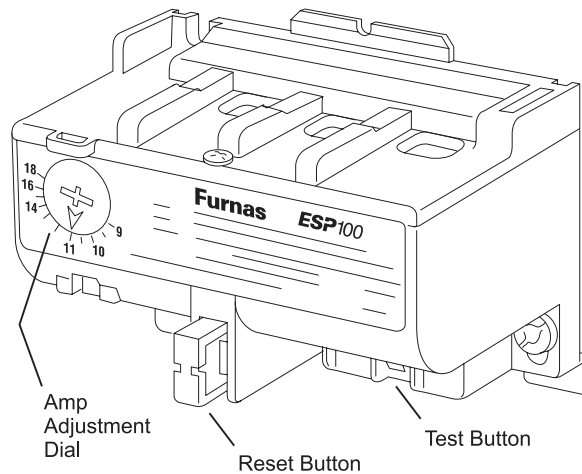

Siemens 3RB12 Electronic Overload Relay

In addition to heaterless construction and phase loss protection, the 3RB12 offers ground fault protection, phase unbalance, LED displays (ready, ground fault, and overload), automatic reset with remote capability, and selectable trip classes (5, 10, 15, 20, 25, or 30). The 3RB12 is self-monitoring and is provided with 2 normally open and 2 normally closed isolated auxiliary contacts.

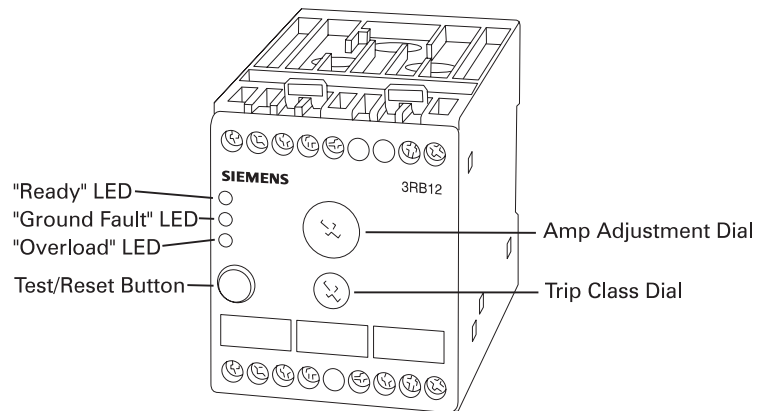

Review 3

1. With an increase in current, heat will _____ .
 - a. increase
 - b. decrease
 - c. remain the same
2. The *National Electrical Code*® defines overcurrent as *any current in _____ of the rated current of equipment or the ampacity of a conductor.*
3. An _____ occurs when electrical equipment is required to work harder than it is rated.
4. A Class _____ overload relay will trip an overloaded motor offline within 10 seconds at six times full-load amps.
 - a. 10
 - b. 20
 - c. 30
5. A _____ strip uses two dissimilar metals bonded together.

Manual Control

Manual control, as the name implies, are devices operated by hand. A simple knife switch, like the one shown in the following illustration, was the first manual-control device used to start and stop motors. The knife switch was eventually replaced with improved control designs, such as manual and magnetic starters.

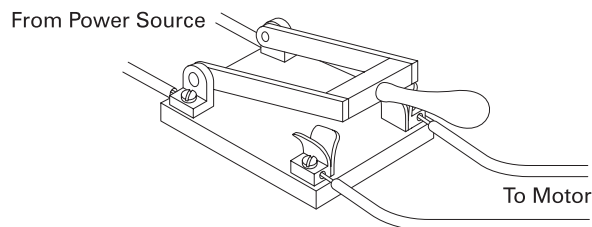

Basic Operation

The *National Electrical Code*[®] requires that a motor control device must also protect the motor from destroying itself under overload conditions. Manual starters, therefore, consist of a manual contactor, such as a simple switch mechanism, and a device for overload protection. The following diagram illustrates a single-pole manual motor starter. Each set of contacts is called a pole. A starter with two sets of contacts would be called a two-pole starter.

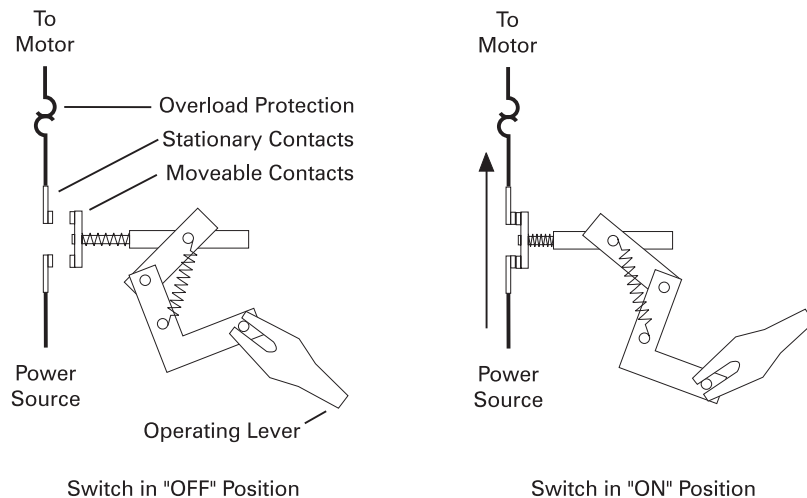

Two-Pole Manual Starter

Starters are connected between the power source and the load. For example, a Two-pole or single-phase motor starter is connected to a motor. When the switch is in the "OFF" position, the contacts are open preventing current flow to the motor from the power source. When the switch is in the "ON" position, the contacts are closed and current flows from the power source (L1), through the motor, returning to the power source (L2).

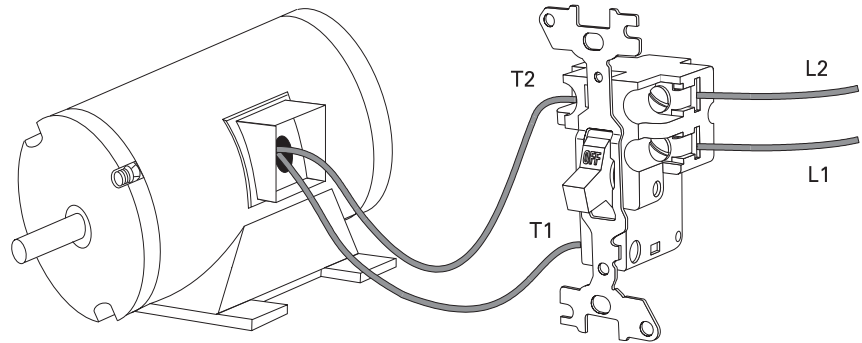

This is represented with a line drawing and symbols as illustrated in the following drawing.

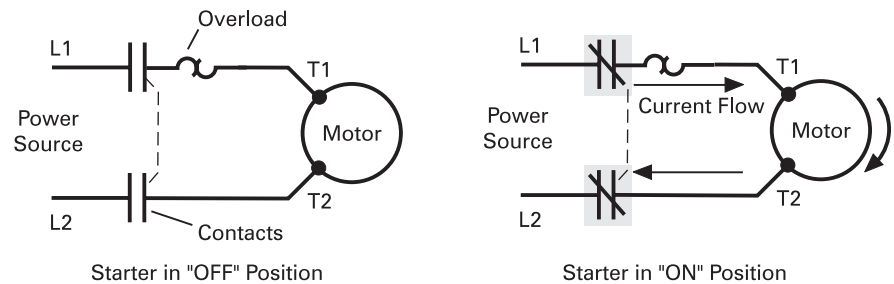

Low Voltage Protection

Some manual motor starters offer low-voltage protection (LVP) as an option. LVP will automatically remove power from the motor when incoming power drops or is interrupted. The starter must be manually reset when power is restored. This protects personnel from potential injury caused by machinery that may otherwise automatically restart when power is restored.

SMF Fractional-Horsepower Manual Starters

Siemens SMF fractional-horsepower starters provide overload protection and manual "ON/OFF" control for small motors. SMF starters are available in one- or two-pole versions suitable for AC motors up to 1 HP and 277 VAC. The two-pole version is suitable for DC motors up to 3/4 HP and 230 VDC. SMF manual starters are available in a variety of enclosures. A two-speed version is available.

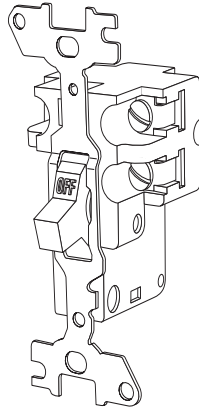

Two-Pole Manual Starter

MMS and MRS Manual Switches

Siemens MMS and MRS manual switches are similar to SMF starters but do not provide overload protection. MMS and MRS switches only provide manual "ON/OFF" control of single- or three-phase AC motors where overload protection is provided separately. These devices are suitable for use with three-phase AC motors up to 10 HP and 600 VAC and up to 1-1/2 HP and 230 VDC. The MMS and MRS manual switches are available in various enclosures. Two-speed and reversing versions are available.

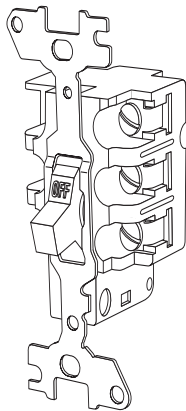

Three-Pole Manual Switch

**Furnas Class 11
Manual Starter
and Manual Contactor**

Furnas Class 11 manual starters use a melting-alloy overload relay with interchangeable heater elements and a manual reset. It has a maximum rating of 10 HP at 460 VAC (3Ø) and 5 HP at 230 VAC (1Ø). Class 11 manual starters are available in a complete line of general-purpose and industrial-duty enclosures. Class 11 manual starters may also be furnished with a low-voltage protection circuit. Class 11 manual contactors provide no overload protection.

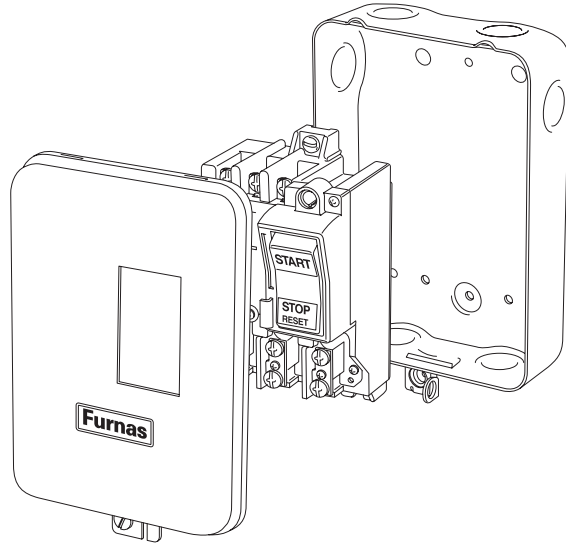

**3RV10 Motor Starter
Protectors**

3RV10 motor starter protectors (MSPs) are part of the Siemens Sirius 3R motor control product line. A thermal overload with a bimetal strip is used to provide overload protection with the 3RV10 motor starter protector. 3RV10 MSPs come in four frame sizes: 3RV101, 3RV102, 3RV103, and 3RV104.

Frame	Max Current at 460 VAC	Max HP at 460 VAC
3RV101	12 Amps	7.5
3RV102	25 Amps	20
3RV103	50 Amps	40
3RV104	100 Amps	75

The 3RV101 is available in both screw-terminal and CAGE CLAMP™ versions. The 3RV102, 3RV103, and 3RV104 are available with screw terminals.

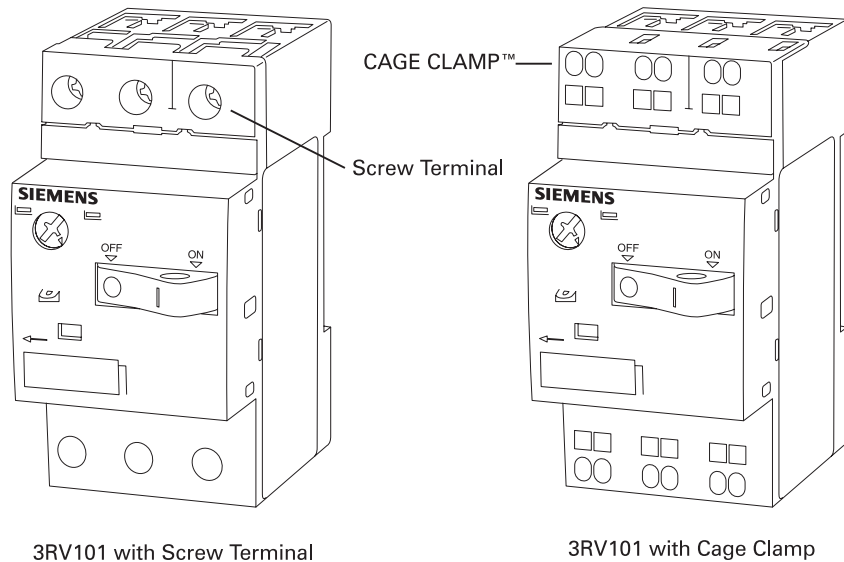

CAGE CLAMP™

The CAGE CLAMP™ is available on many Siemens Sirius 3R products including the MSPs. To connect a wire, simply push an electrician blade screwdriver into the appropriate portal, insert the stripped end of the wire into the portal directly above, remove the screwdriver, and the wire is securely connected. CAGE CLAMP™ devices are especially beneficial in installations that are subject to vibration.

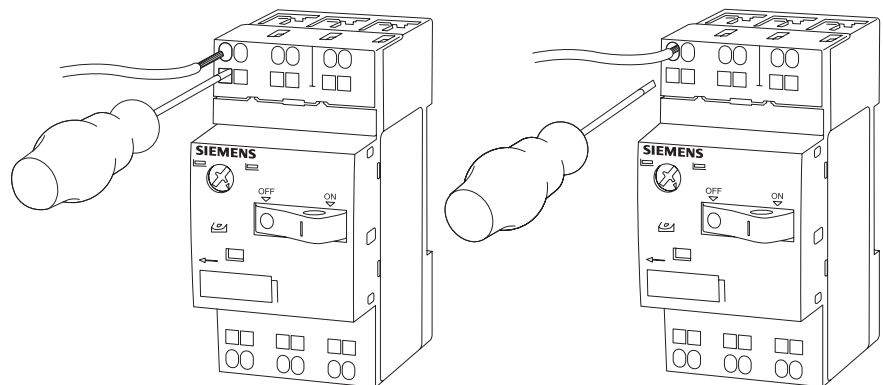

Enclosures and Options

Siemens 3RV10 MSPs are available in a variety of enclosures. Several options, such as indicator lights, are also available.

Reversing Drum Controller

Manually operated drum controllers, like the Furnas Class 58 reversing drum controller, stop and change direction of reversible AC motors. Overload protection is not provided by the reversing drum controller and must be supplied by an external means. The Furnas Class 58 reversing drum controller is rated for 10 HP at 460 VAC. Another style of drum switch is used to change speed of multi-speed motors.

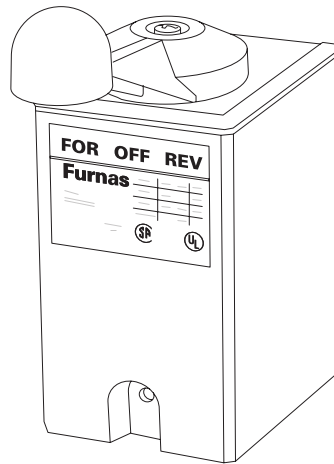

Reversing Drum Controller

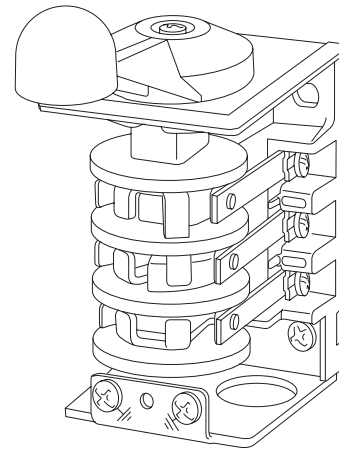

Reversing Drum Controller
With Cover Removed

Foot Switch

The Furnas Class 56 foot switch is another type of manual control. Typical applications include the control of drill presses, conveyors, tapping machines, etc. Foot switches, rated for across-the-line operations, operate motors up to 7.5 HP at 460 VAC. They come in either momentary or maintained operations as well as reversing.

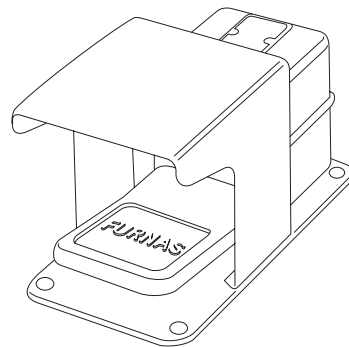

Master Switch

The Furnas Class 53 master switches provide single-handle control of hoists, cranes, oven pushers, and other equipment requiring speed steps of wound rotor or direct-current motors. Master switches are available with momentary or maintained contacts and up to five speed settings.

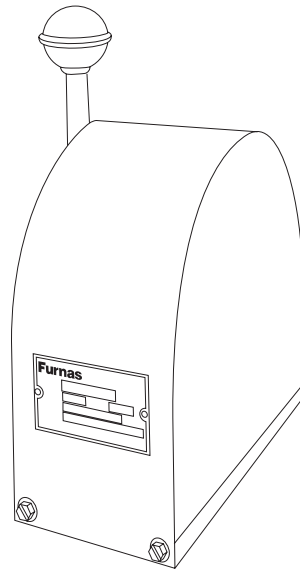

Magnetic Contactors and Starters

Most motor applications require the use of remote control devices to start and stop the motor. Magnetic contactors, similar to the ones shown below, are commonly used to provide this function. Contactors are also used to control distribution of power in lighting and heating circuits.

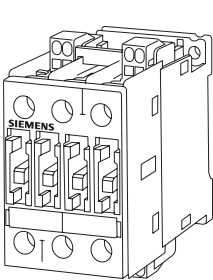

Sirius 3R

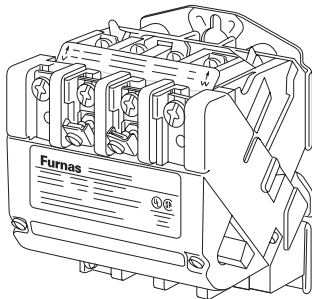

INNOVA Series

Basic Contactor Operation

Magnetic contactors operate utilizing electromagnetic principles. A simple electromagnet can be fashioned by winding a wire around a soft iron core. When a DC voltage is applied to the wire, the iron becomes magnetic. When the DC voltage is removed from the wire, the iron returns to its nonmagnetic state. This principle is used to operate magnetic contactors.

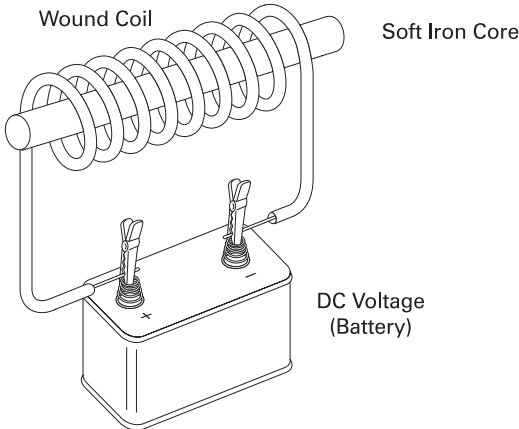

The following illustration shows the interior of a basic contactor. There are two circuits involved in the operation of a contactor: the control circuit and the power circuit. The control circuit is connected to the coil of an electromagnet, and the power circuit is connected to the stationary contacts.

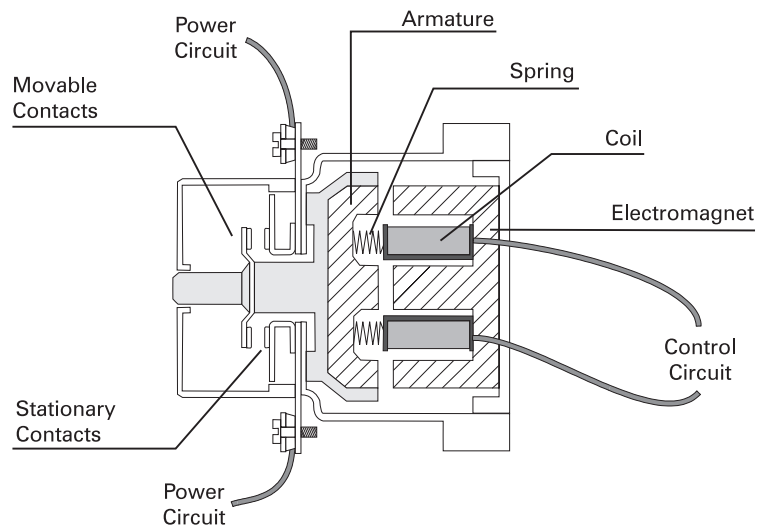

The operation of this electromagnet is similar to the operation of the electromagnet we made by wrapping wire around a soft iron core. When power is supplied to the coil from the control circuit, a magnetic field is produced magnetizing the electromagnet. The magnetic field attracts the armature to the magnet, which in turn closes the contacts. With the contacts closed, current flows through the power circuit from the line to the load. When the electromagnet's coil is deenergized, the magnetic field collapses and the movable contacts open under spring pressure. Current no longer flows through the power circuit.

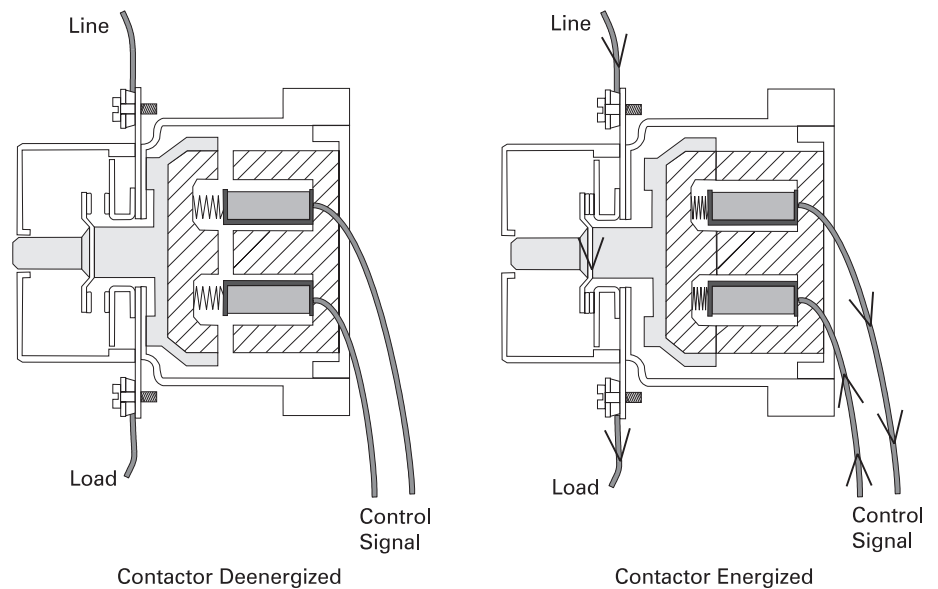

The following schematic shows the electromagnetic coil of a contactor connected to the control circuit through a switch (SW1). The contacts of the contactor are connected in the power circuit to the AC line and a three-phase motor. When SW1 is closed, the electromagnetic coil is energized, closing the "M" contacts and applying power to the motor. Opening SW1 deenergizes the coil and the "M" contacts open, removing power from the motor.

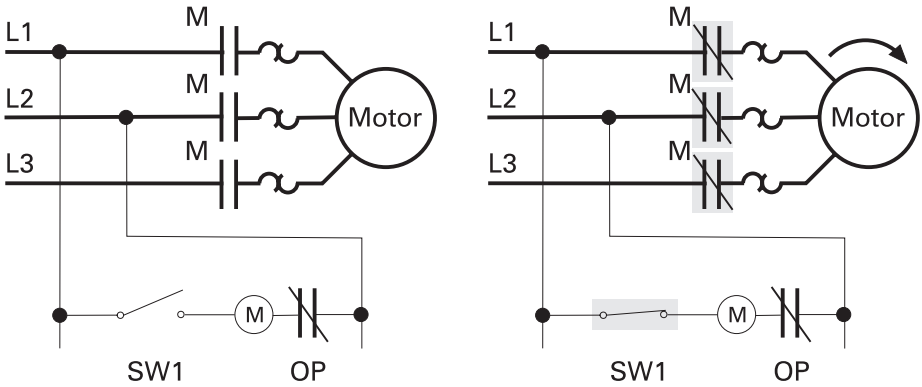

Overload Relay

Contactors are used to control power in a variety of applications. When applied in motor-control applications, contactors can only start and stop motors. Contactors cannot sense when the motor is being loaded beyond its rated conditions. They provide no overload protection. Most motor applications require overload protection. However, some smaller-rated motors have overload protection built into the motor (such as a household garbage disposal). Overload relays, similar to the one shown below, provide this protection. The operating principle, using heaters and bimetal strips, is similar to the overloads discussed previously.

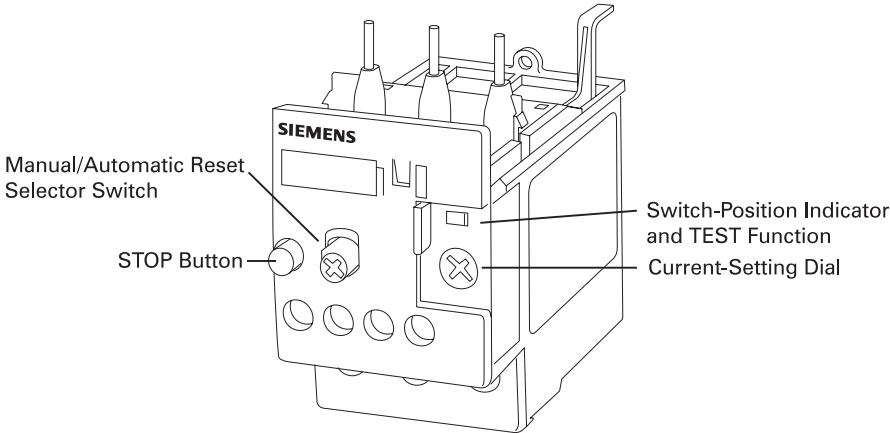

Motor Starter

Contactors and overload relays are separate control devices. When a contactor is combined with an overload relay, it is called a motor starter.

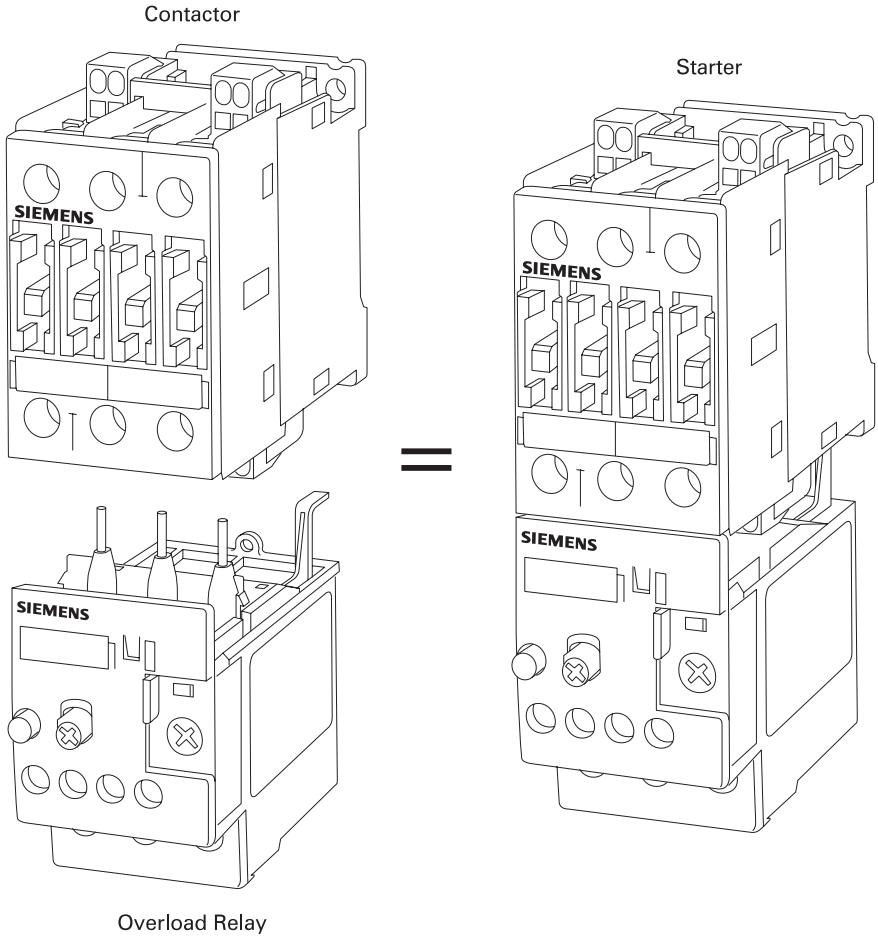

Motor Starter in a Control Circuit

The following diagram shows the electrical relationship of the contactor and overload relay. The contactor, highlighted with the darker grey, includes the electromagnetic coil, the main motor contacts, and the auxiliary contacts. The overload relay, highlighted by the lighter grey, includes the "OL" heaters and overload contacts. The contactor and the overload relay have additional contacts, referred to as auxiliary contacts, for use in the control circuit. In this circuit a normally closed "OL" contact has been placed in series with the "M" contactor coil and L2. A normally open "M" auxiliary contact ("Ma") has been placed in parallel with the "Start" pushbutton.

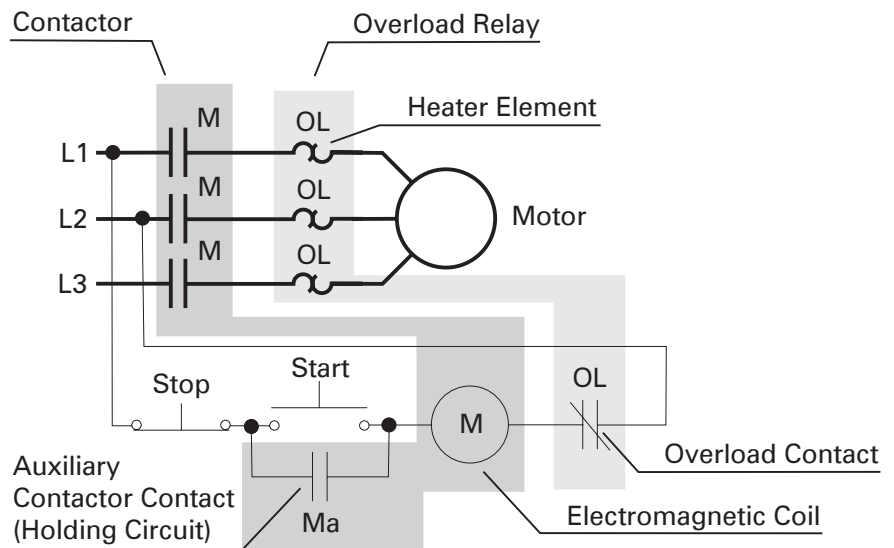

Review 4

1. A starter with two sets of contacts would be called a _____-pole starter.
2. _____ will automatically disconnect power from the motor when incoming power drops or is interrupted.
3. The Furnas Class 11 motor starter protects motors up to _____ HP at 460 VAC and _____ HP at 230 VAC.
4. The 3RV102 motor starter protector protects motors up to _____ HP at 460 VAC.
5. When a contactor is combined with an overload relay, it is called a _____ .

Starter Ratings

Starter contactors are rated according to size and type of load they handle. The National Electrical Manufacturers Association (NEMA) and the International Electrotechnical Commission (IEC) are two organizations that rate contactors and motor starters. NEMA is primarily associated with equipment used in North America. IEC, on the other hand, is associated with equipment sold in many countries including the United States. International trade agreements, market globalization, and domestic and foreign competition have made it important for controls manufacturers to be increasingly aware of international standards.

NEMA

NEMA ratings are maximum horsepower ratings, according to the National Electrical Manufacturers Association ICS2 standards. NEMA starters and contactors are selected according to their NEMA size. These sizes range from size 00 to size 9.

NEMA Size	Continuous Amp Rating	HP 230 VAC	HP 460 VAC
00	9	1	2
0	18	3	5
1	27	7	10
2	45	15	25
3	90	30	50
4	135	50	100
5	270	100	200
6	540	200	400
7	810	300	600
8	1215	450	900
9	2250	800	1600

NEMA motor-control devices have generally become known for their very rugged, heavy-duty construction. Because of their rugged design NEMA devices are physically larger than IEC devices. NEMA motor starters and contactors can be used in virtually any application at their stated rating, from simple “ON” and “OFF” applications to more-demanding applications that include plugging and jogging. To select a NEMA motor starter for a particular motor one need only know the horsepower and voltage of the motor. If there is considerable plugging and jogging duty involved, however, even a NEMA-rated device will require some derating.

Motor Matched Sizes

Siemens also has what are called Motor Matched sizes available on some Siemens motor starters. The ratings for these devices fall in between the ratings of normal NEMA sizes. This allows the user to more closely match the motor control to the actual application. The following table shows Motor Matched sizes available.

MM Size	Continuous Amp Rating	HP 230 VAC	HP 460 VAC
1¾	40	10	15
2½	60	20	31
3½	115	40	75
4½	210	75	150

IEC

Not all applications require a heavy-duty industrial starter. In applications where space is more limited and the duty cycle is not severe, IEC devices represent a cost-effective solution. IEC devices are rated for maximum operational current as specified by the International Electrotechnical Commission in publication IEC 158-1. IEC does not specify sizes. Utilization categories are used with IEC devices to define the typical duty cycle of an IEC device. AC-3 and AC-4 are the categories of most interest for general motor-starting applications.

Utilization Category	IEC Category Description
AC1	Non-inductive or slightly inductive loads.
AC2	Starting of slip-ring motors.
AC3	Starting of squirrel-cage motors and switching off only after the motor is up to speed. (Make LRA, Break FLA)
AC4	Starting of squirrel-cage motors with inching and plugging duty. Rapid Start/Stop. (Make and break LRA)
AC11	Auxiliary (control) circuits.

Definite Purpose

Definite Purpose (DP) contactors have certain characteristics which must be taken into consideration. DP contactors were designed for specific applications where the operating conditions are clearly defined. These operating conditions include full load amps, locked rotor amps, noninductive amps (resistive load), number of power poles, duty cycle, and the total number of expected operations.

DP contactors are sized by the motor full-load amps (FLA) and locked rotor amps (LRA). FLA is the amount of current the motor draws at full speed, under full mechanical load, at rated voltage. LRA is the maximum current the motor will draw at the instant full-line voltage is applied to the motor. DP contactors are well suited for loads found in the following areas:

- Heating, Ventilating, and Air Conditioning (HVAC)
- Farm Equipment and Irrigation
- Environmental Control Systems
- Office Equipment
- Pool and Spa Controls
- Welding Equipment
- Medical Equipment
- Food-Service Equipment

Other Organizations

There are several other organizations that have developed standards and tests for electrical equipment. Underwriters Laboratory (UL), for example, specifies a maximum horsepower rating for which a contactor can be used. The contactor is tested by Underwriters Laboratory using test procedure U.L. 508. All Siemens contactors are rated in accordance with at least one of the previous organizations' test procedures. Some carry multiple ratings. For example, Furnas INNOVA starters meet or exceed NEMA and UL standards. Siemens Sirius starters meet or exceed NEMA, IEC, and UL standards.

Furnas INNOVA PLUS Starters

Furnas INNOVA PLUS™ starters are available in NEMA sizes 0 through 4. They are available up to 100 HP.

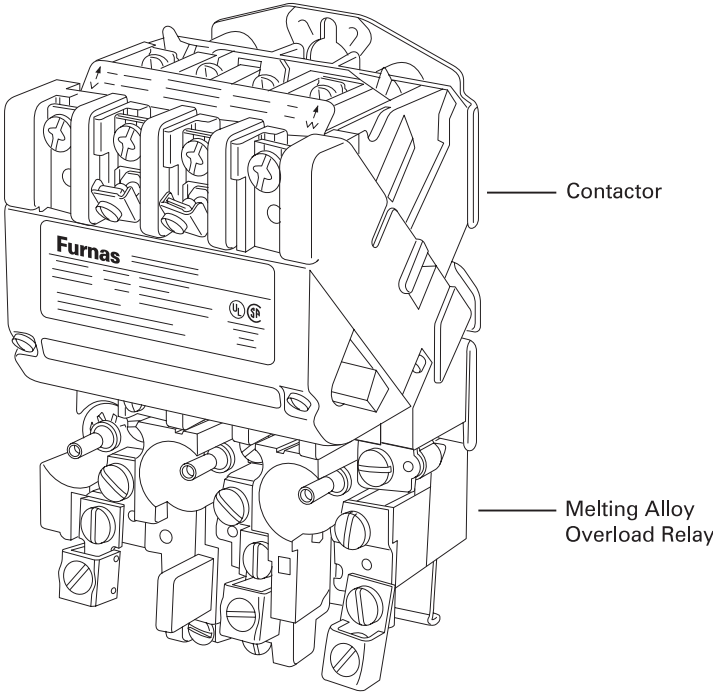

Ambient-Compensated Bimetal Overload Relay

Furnas INNOVA PLUS starters are available with two types of overload relays. A Class 20 melting alloy overload (shown in the above illustration) is standard. INNOVA PLUS is also available with Class 10 or 20 ambient-compensated bimetal overload relay (shown below).

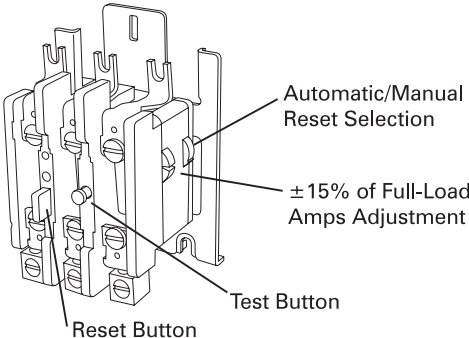

ESP100 Starters

The Furnas ESP100™ starters use the same contactor as the INNOVA PLUS™ starters. The ESP100 starters are supplied with a Class 10, 20, or 30 ESP100 solid-state overload relay. The ESP100 overload relay protects 3Ø motors with FLA of ¼ ampere through 135 amperes. From ¼ ampere to 10 amperes the overload has a 4:1 FLA range, i.e.; 2½ - 10 amperes. Above 10 amperes the range is 2:1. The ESP100 overload relay illustrated below, for example, is adjustable from 9 to 18 amperes. The ESP100 also protects the motor against phase loss. The ESP100 trips within three seconds of loss of one of the power-supply phases.

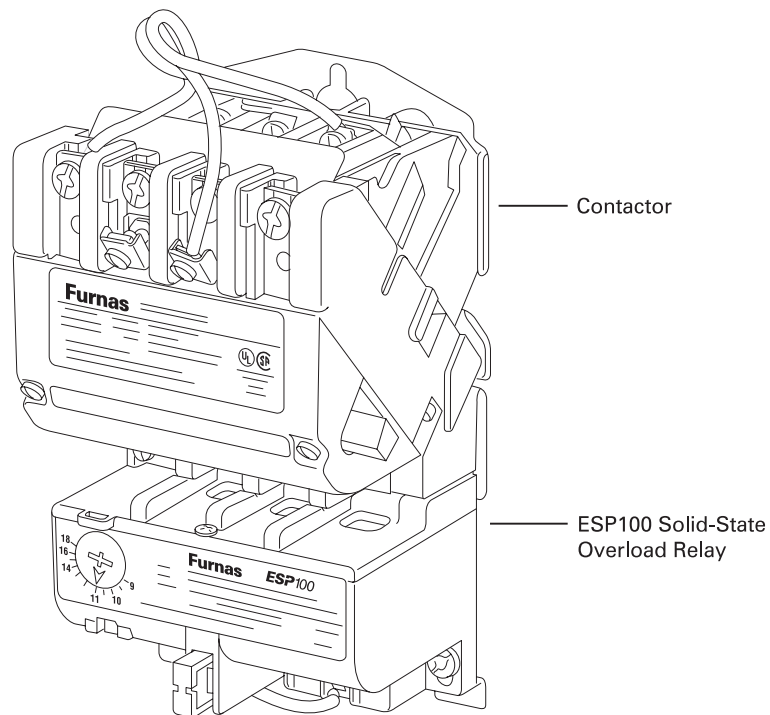

Sirius Type 3R Starters

Sirius 3R is a complete modular, building-block system. The system includes a structured range of contactors and overload relays covering loads up to 95 amps in four frame sizes. These four frame sizes are referred to as S00 (12A), S0 (25A), S2 (50A), and S3 (95A). A feature of the Sirius product line is a narrow mounting width. An S3 contactor rated at 75 HP, for example, is only 70mm (2.75"). Sirius 3R contactors and overload relays can operate in ambient temperatures up to 140°F (60°C). This, along with the smaller size, allows more units to be packed into a panel without overheating the components.

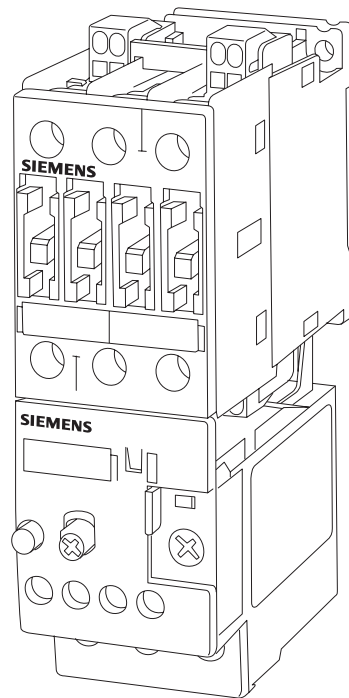

CAGE CLAMP™

Size S00 contactors and overload relays are available with CAGE CLAMP™ connections on power and control-circuit terminals. Size S0, S2, and S3 contactors and overload relays have CAGE CLAMP™ connections on the control-circuit terminals only.

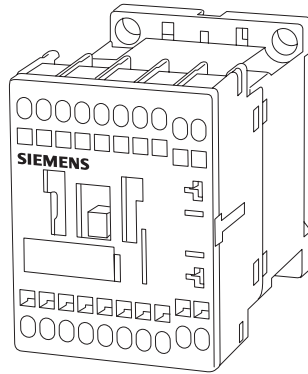

Contactor with
CAGE CLAMP™

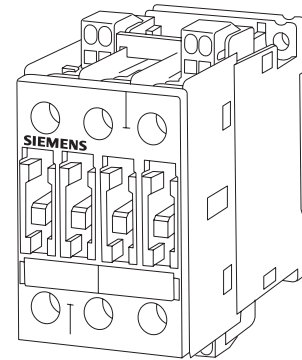

Contactor with
Screw Terminals

Overload Relays

Sirius 3R overload relays provide Class 10 overcurrent protection for both AC and DC motors. Ambient-compensated bimetal strips prevent the overload relay from nuisance tripping when the panel temperature is higher than the ambient temperature of the motor. The design of the overload relay also includes a differential trip bar that causes the unit to trip faster in the event of a phase-loss condition. An optional remote-reset module (not shown) is available.

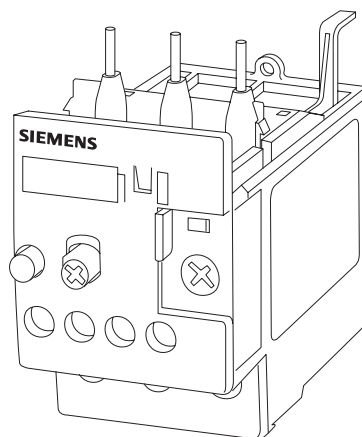

World Series Type 3TF Starters

The World Series starters are supplied with a type 3TF contactor and overload relay. World Series starters are available in horsepower ratings from 100 to 500 HP at 460 VAC. Auxiliary contacts are provided for use in the control circuit. World Series type 3TF contactors are available with various enclosures. Additional auxiliary contacts can be added. Coil voltages for the electromagnetic coil range from 24 to 600 VAC.

The overload relay is a Class 10 relay that uses a bimetal strip unit and heater element to detect overloads. Each phase monitors current. The unit has a full-load amps adjustment, test button, and reset button. The full-load amps adjustment corresponds to the range of the motor full-load ampere rating. The test button is to ensure the overload relay is functioning properly. The reset button is used to reset a trip. It can be either automatic or manual reset. There is also a trip indicator.

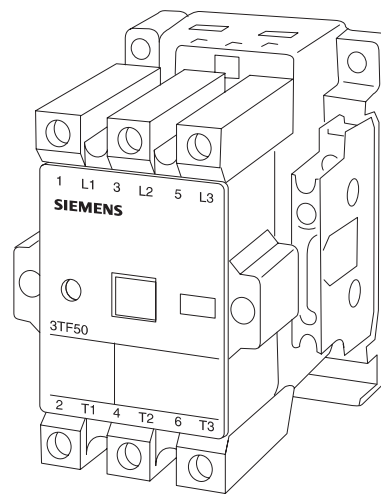

3TF50 Contactor

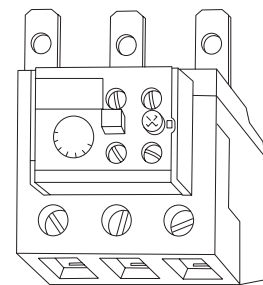

3UA Overload Relay

Overload Relay Selection

The following chart is useful in selecting the correct contactor and overload-relay combination. The chart reflects the maximum horsepower rating using Underwriters Laboratory test procedure U.L. 508 and the appropriate overload relay.

Contactor	Max HP (at 460 VAC)	Overload Relay
3TF50	100	3UA60
3TF51	100	3UA61
3TF52	125	3UA62
3TF53	150	3UA62
3TF54	200	3UA66
3TF55	250	3UA66
3TF56	300	3UA66
3TF57	400	3UA68
3TF68	500	3UA68

Review 5

1. _____ is an organization primarily associated with rating equipment used in North America and _____ is associated with rating equipment used in many countries including the U.S.
2. A NEMA Size _____ starter is rated for 200 HP at 460 volts .
3. IEC utilization category _____ applications are described as the starting of squirrel-cage motors and switching off only after a motor is up to speed.
4. Furnas INNOVA PLUS™ starters are available in NEMA sizes 0 through _____ .
5. The ESP100 trips within _____ seconds of loss of one of the power-supply phases.
6. The maximum load current of a size S2 Sirius 3R starter is _____ amps.
7. The correct overload relay for a 3TF54 contactor is _____ .

Multi-Speed and Reversing Starters

Full-voltage AC magnetic multi-speed controllers are designed to control squirrel-cage induction motors for operation at two, three, or four different constant speeds, depending on motor construction. The speed of a constant-speed motor is a function of the supply frequency and the number of poles and is given in the following formula:

$$\text{Synchronous Speed in RPM} = \frac{120 \times \text{Frequency}}{\text{Number of Poles}}$$

The speed in RPM is the synchronous speed or the speed of the rotating magnetic field in the motor stator. Actual rotor speed is always less due to slip. The design of the motor and the amount of load applied determine the percentage of slip. This value is not the same for all motors. A motor with four poles on a 60 hertz AC line has a synchronous speed of 1800 RPM. This means that, after allowing for slip, the motor is likely to run at 1650 to 1750 RPM when loaded.

$$1800 = \frac{120 \times 60}{4}$$

An induction motor with two poles on a 60 hertz AC line, however, would run at twice that speed.

When motors are required to run at different speeds, the motor's torque or horsepower characteristics will change with a change in speed. The proper motor must be selected and correctly connected for the application. In these applications, there are three categories.

Constant Torque (CT)

Variable Torque (VT)

Constant Horsepower (CHP)

Separate-Winding

There are two basic methods of providing multi-speed control using magnetic starters: separate-winding motors and consequent-pole motors. Separate-winding motors have a separate winding for each speed. The speed of each winding depends on the number of poles. The low-speed winding is wound for more poles than the high-speed winding. The motor cost is higher than consequent pole, but the control is simpler. There are many ways multi-speed motors can be connected depending on speed, torque, and horsepower requirements. The following schematic shows one possible connection of a two-speed, two-winding, wye-connected motor.

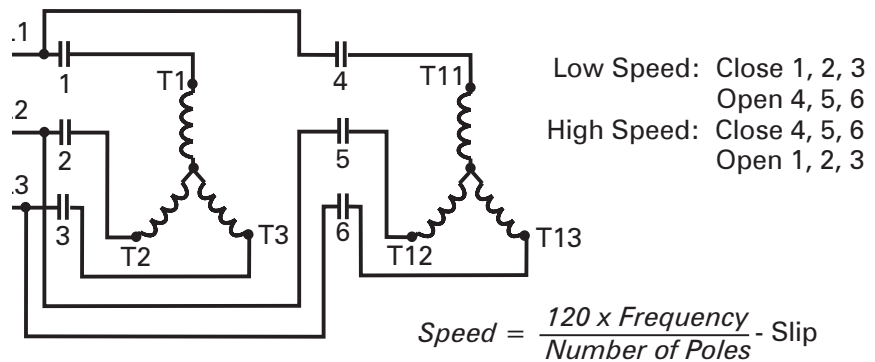

Consequent-Pole Motors

Consequent-pole motors have a single winding for two speeds. Taps can be brought from the winding for reconnection for a different number of poles. Two-speed, consequent-pole motors have one reconnectable winding. Low speed of a two-speed, consequent-pole motor is one half the speed of high speed. Three-speed motors have one reconnectable winding and one fixed winding. Four-speed motors have two reconnectable windings.

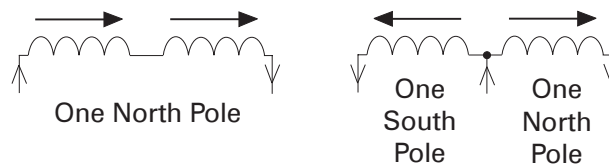

Speed Selection

There are three control schemes of speed selection for multi-speed motors: selective control, compelling control, and progressive control. Selective control permits motor starting at any speed and to move to a higher speed the operator depresses the desired speed pushbutton. Compelling control requires the motor to be started at the lowest speed, then the operator must manually increment through each speed step to the desired speed. With progressive control the motor is started at the lowest speed and automatically increments to the selected speed.

Reversing

Many applications require a motor to run in both directions. In order to change the direction of motor rotation, the direction of current flow through the windings must be changed. This is done on a three-phase motor by reversing any two of the three motor leads. Traditionally T1 and T3 are reversed. The following illustration shows a three-phase reversing motor circuit. It has one set of forward (F) contacts controlled by the "F" contactor, and one set of reverse (R) contacts controlled by the "R" contactor.

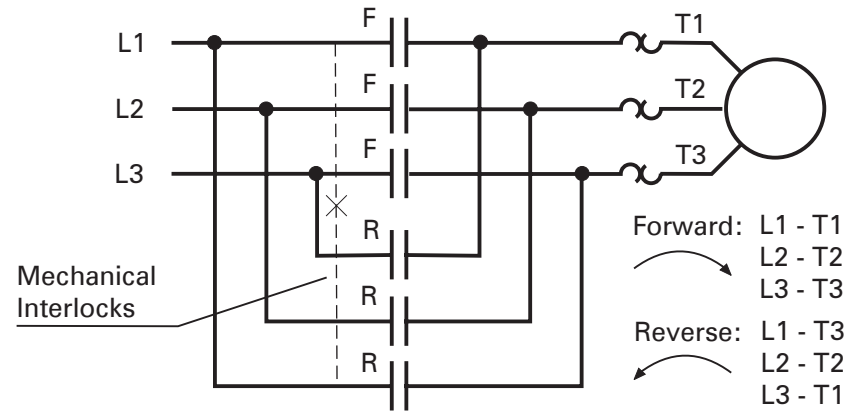

When the "F" contacts are closed, current flows through the motor causing it to turn in a clockwise direction.

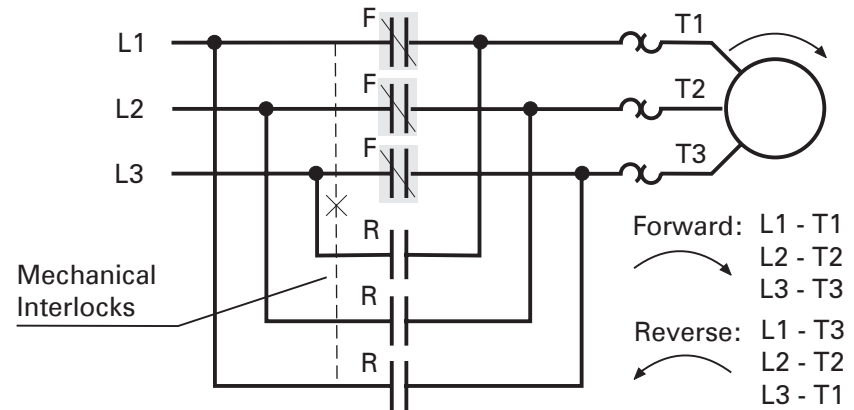

When the "R" contacts are closed, current flows through the motor in the opposite direction causing it to rotate in a counterclockwise direction. Mechanical interlocks prevent both forward and reverse circuits from being energized at the same time.

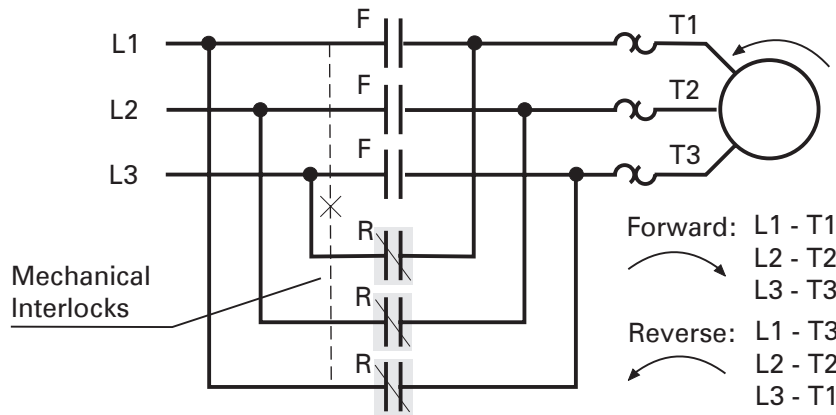

Reduced-Voltage Starting

Full-Voltage Starting

The most common type of motor starting is full-voltage starting. The motor is placed directly across the line with this method.

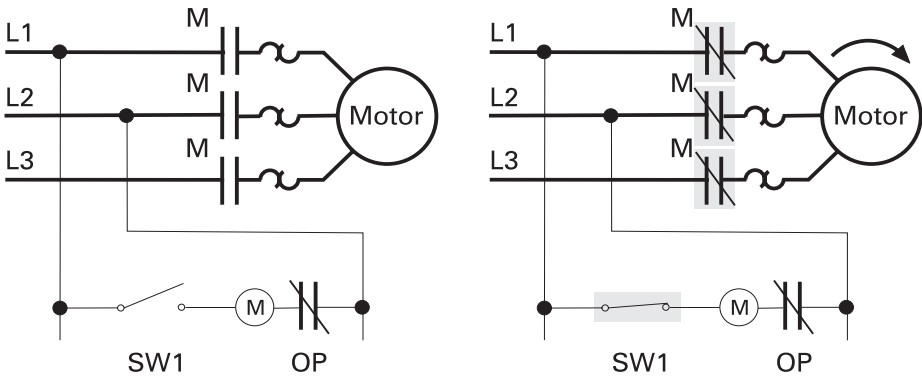

With this type of starter the motor receives the full-line voltage. When a motor is started with full voltage, starting current can be as high as 600% of full-load current on standard squirrel cage motors. It can be even higher on high efficiency motors. There are situations where this method of starting is not acceptable. On large motors the high starting current is reflected back into the power lines of the electric utility, causing lights to flicker and in more serious situations can cause computers to malfunction. Many power companies in the U.S. require reduced-voltage starting on large-horsepower motors.

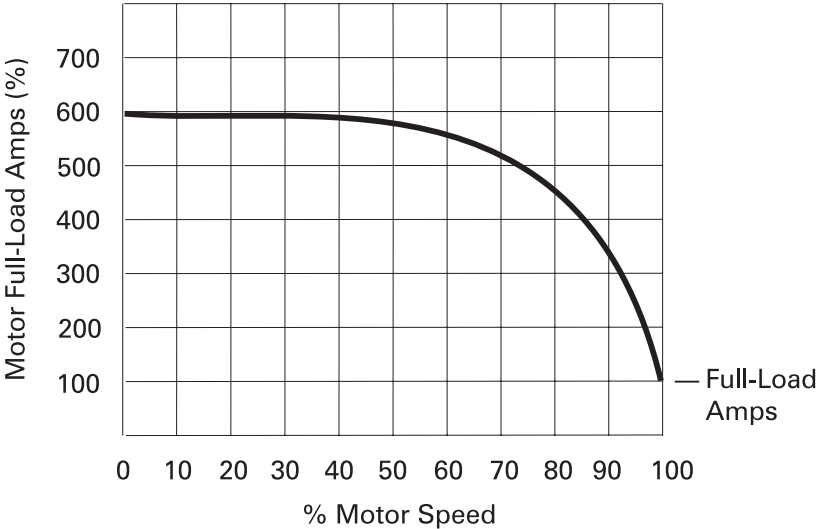

Another potential problem with applying full-voltage starts is the high torque developed when power is first applied to the motor. This can be as high as 175% to 200% of full-load torque on a standard NEMA B type motor. Many applications require the starting torque to be applied gradually. A conveyor belt, for example, requires the starting torque to be applied gradually to prevent belt slipping or bunching.

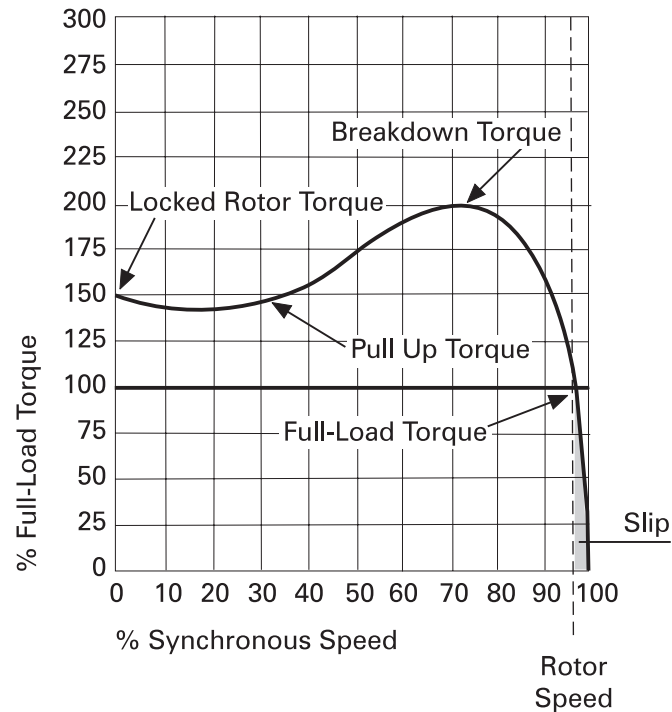

Reduced-Voltage Starting

In general, starting methods which deviate from full-voltage starting by providing a lower starting voltage are referred to as reduced-voltage starting. Reduced-voltage starting should be used when it is necessary to limit the initial inrush of current or it is desired to reduce the starting torque of a motor.

Reduced-voltage starting reduces the starting voltage of an induction motor with the purpose of confining the rate of change of the starting current to predetermined limits. It is important to remember that when the voltage is reduced to start a motor, current is also reduced, which also reduces the amount of starting torque a motor can deliver. Several methods are available for reduced-voltage starting. The application or the type of motor generally dictates the method to use. A few of the methods offered by Siemens are described in the following paragraphs.

Autotransformer Reduced-Voltage Starters

Autotransformer reduced-voltage starters provide the highest starting torque per ampere of line current and is one of the most effective means of starting a motor for an application in which starting current must be reduced with a minimum sacrifice of starting torque. Autotransformers have adjustable taps to reduce starting voltage to 50%, 65%, or 80% of full-line voltage.

Applications: Blowers, Pumps, Compressors

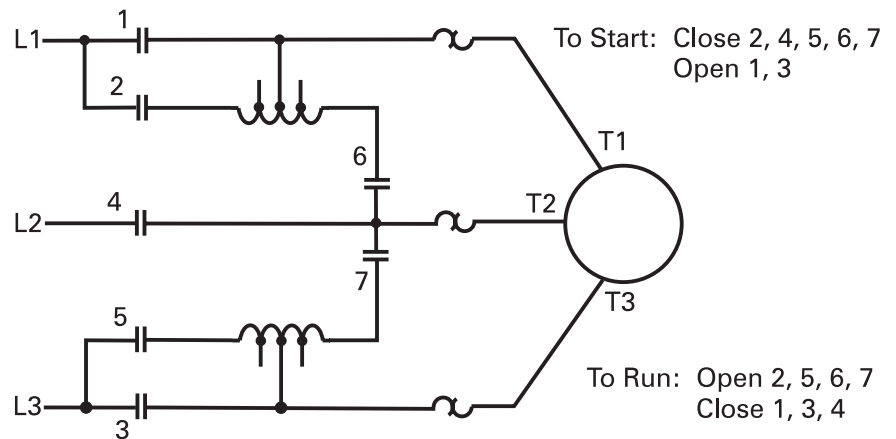

Part-Winding Starters

Part-winding, reduced-voltage starters are used on motors with two separate parallel windings on the stator. The windings used during start draw about 65 - 80% of rated locked rotor current. During run each winding carries approximately 50% of the load current. Part-winding, reduced-voltage starters are the least-expensive type of reduced-voltage starters and use a very simplified control circuit. However, they require special motor design and are not suitable for high inertia loads. There is no adjustment of current or torque.

Applications: Pumps, Fans, Refrigeration, Compressors

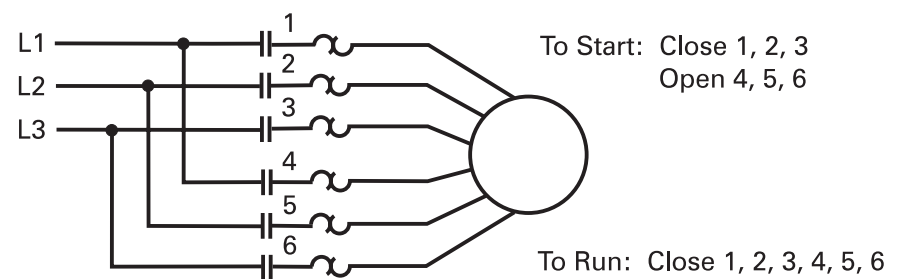

Wye-Delta Starters

Wye-delta, reduced-voltage starters are applicable only with motors having stator windings not connected internally and all six motor leads available. Connected in a wye configuration, the motor starts with reduced starting line current. The motor is reconfigured to a delta connection for run. This type of starter is a good method for applications requiring frequent starts. The starting torque is lower compared to other methods of reduced voltage starters.

Applications: Central Air Conditioning Equipment, Compressors

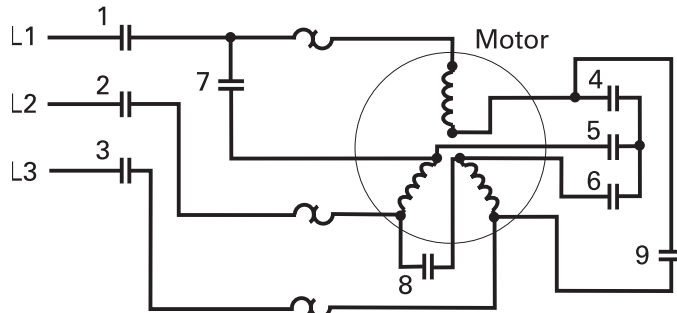

To Start: Close 1, 2, 3, 4, 5, 6
Open 7, 8, 9

To Run: Open 4, 5, 6
Close 7, 8, 9

Primary Resistance Starter

This is a simple and effective starting method. The motor is initially energized through a resistor in each of the three incoming lines. Part of the voltage is dropped through the resistors. The motor receives 70% to 80% of the full-line voltage. As the motor picks up speed, the motor sees more of the line voltage. At a preset time a time-delay relay closes a separate set of contacts, shorting out the resistors and applying full voltage to the motor. This type of reduced voltage starting is limited by the amount of heat the resistors can dissipate.

Applications: Conveyors, Belt-Driven and Gear Drive Equipment

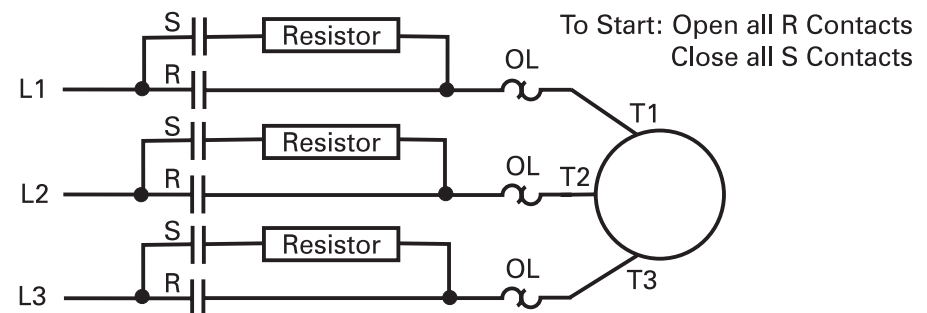

To Start: Open all R Contacts
Close all S Contacts

To Run: Close all R Contacts

Furnas Nordic Solid-State, Reduced-Voltage Starters

The Furnas Nordic solid-state, reduced-voltage starter line has a wide variety of products for different applications. Specific controllers are available for 10 - 700 HP and voltages of 110/230 VAC and 200 - 575 VAC. Nordic provides smooth, soft starts and stops. Contact your Siemens representative for additional information on reduced voltage starters including Nordic products.

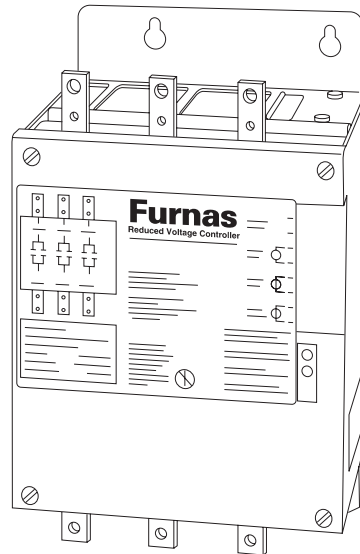

Review 6

1. _____ - _____ _____ is a method of providing multi-speed control that utilize taps brought out from a reconnectable winding.
2. With _____ _____ the motor is started at the lowest speed and automatically increments to the selected speed.
3. In general, starting methods which deviate from full-voltage starting by providing a lower starting voltage are referred to as _____ _____ .
4. _____ reduced-voltage starters have adjustable taps to reduce starting voltage to 50%, 65%, or 80% of full line voltage.
5. The Furnas _____ is a solid-state, reduced-voltage starter.

Pilot Devices

A pilot device directs the operation of another device (pushbuttons and selector switches) or indicates the status of the operating system (pilot lights). This section discusses Siemens 3SB and Furnas Class 51/52 pushbuttons, selector switches, and pilot lights. 3SB0 devices are available in 22 mm and 30 mm diameters. Class 51/52 pilot devices are available in 30 mm diameter only. The diameter refers to the size of the knockout hole required to mount the devices. Class 51 devices are rated for hazardous locations environments such as Class I, Groups C and D and Class II, Groups E, F, and G. Class 52 devices are heavy duty for harsh, industrial environments.

Bifurcated Contacts

Whether one chooses the 3SB or the Class 51/52 pilot devices, the fine silver contacts have a 10 A/600 V continuous-current rating and can be used on solid state equipment. The 3SB and the Class 51/52 devices use bifurcated movable contacts. The design of the bifurcated contacts provides four different pathways for current to flow, thus improving contact reliability.

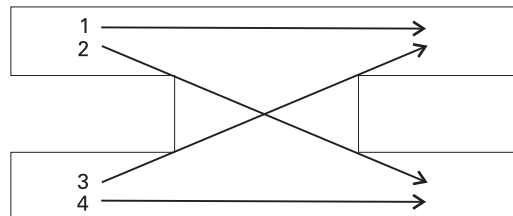

Bifurcated Contact
Four Paths of Current Flow

Pushbuttons

A pushbutton is a control device used to manually open and close a set of contacts. Pushbuttons are available in a flush mount, extended mount, with a mushroom head, illuminated or nonilluminated. Pushbuttons come with either normally open, normally closed, or combination contact blocks. The Siemens 22 mm and 30 mm pushbuttons can handle up to a maximum of 10 circuits. The Furnas 30 mm pushbutton can handle up to a maximum of 16 circuits.

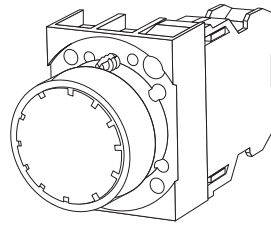

Siemens
22 mm Diameter
Pushbutton

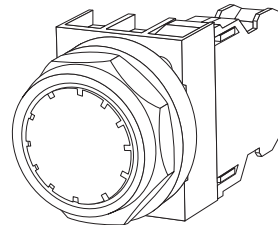

Siemens
30 mm Diameter
Pushbutton

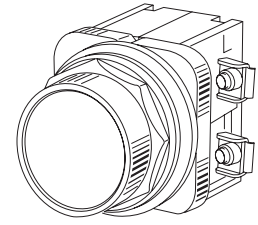

Furnas
30 mm Class 52
Pushbutton

Normally Open Pushbuttons

Pushbuttons are used in control circuits to perform various functions. For example, pushbuttons can be used when starting and stopping a motor. A typical pushbutton uses an operating plunger, a return spring, and one set of contacts. The following drawing illustrates a normally open (NO) pushbutton. Normally the contacts are open and no current flows through them. Depressing the button causes the contacts to close. When the button is released, the spring returns the plunger to the open position.

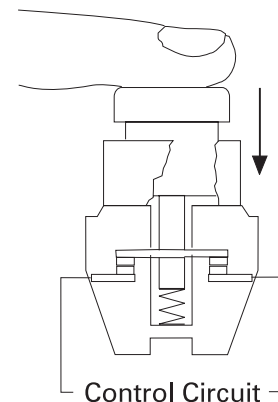
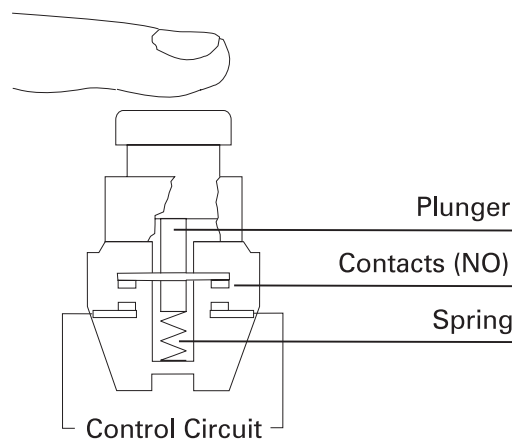

Normally Closed Pushbuttons

Normally closed (NC) pushbuttons, such as the one shown below, are also used to open and close a circuit. In the pushbutton's normal position the contacts are closed to allow current flow through the control circuit. Depressing the button opens the contacts preventing current flow through the circuit. These types of pushbuttons are momentary contact pushbuttons because the contacts remain in their activated position only as long as the plunger is held depressed.

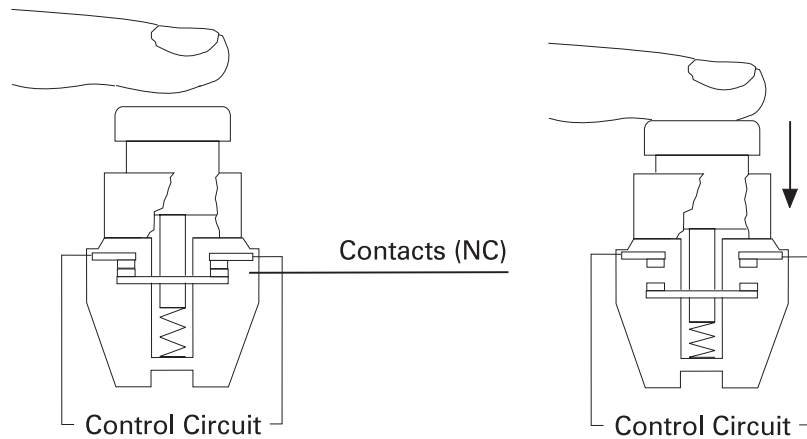

Pushbuttons are available with variations of the contact configuration. For example, a pushbutton may have one set of normally open and one set of normally closed contacts so that when the button is depressed, one set of contacts is open and the other set is closed. By connecting to the proper set of contacts, either a normally open or normally closed situation exists.

Using Pushbuttons in a Control Circuit

The following line diagram shows an example of how a normally open and a normally closed pushbutton might be used in a control circuit.

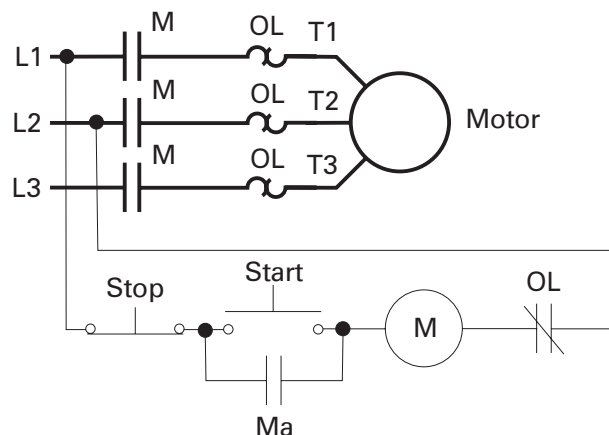

Momentarily depressing the "Start" pushbutton completes the path of current flow and energizes the "M" contactor's electromagnetic coil.

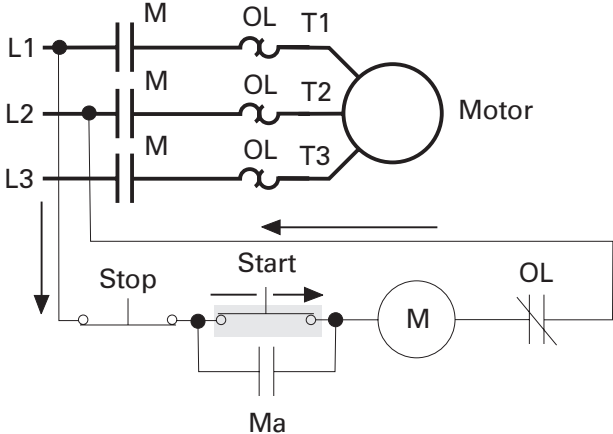

**Holding Circuit
Three-Wire Control**

This closes the associated normally open "M" and "Ma" contacts. When the "Start" pushbutton is released a holding circuit exists to the "M" electromagnetic coil through the auxiliary contacts "Ma". The motor will run until the normally closed "Stop" pushbutton is depressed, breaking the path of current flow to the "M" electromagnetic coil and opening the associated "M" and "Ma" contacts. This is referred to as three-wire control because there are three wires or three connection points required to connect the "Start" and "Stop" pushbuttons and the holding circuit ("Ma"). An advantage to three-wire control is low-voltage protection. If an overload causes the "OL" contacts in the control circuit to open, the "M" coil is deenergized and the motor shut down. When the overload is cleared, the motor will not suddenly restart on its own. An operator must depress the "Start" button to restart the motor.

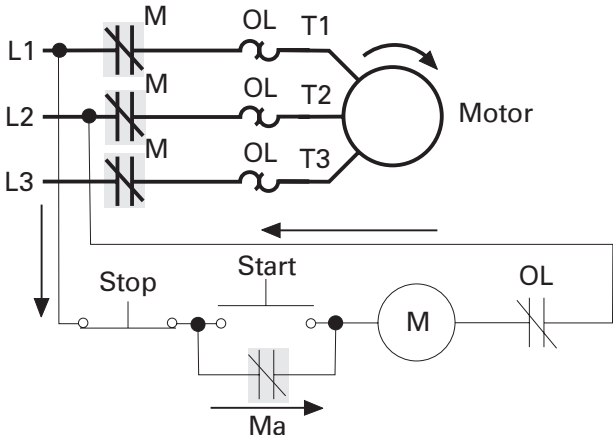

Two-Wire Control

In comparison, a two-wire control has only two connection points for the "Start/Stop" circuit. When the contacts of the control device close, they complete the coil circuit of the contactor, causing it to be energized and connect the load to the line through the power contacts. When the contacts of the control device open, the power is removed from the motor and it stops.

A two-wire control circuit provides low-voltage release but not low-voltage protection. This means that in the event of a power loss the contactor will deenergize, stopping the motor. This is low-voltage release. However, when power is restored, the motor will restart without warning if the control device is still closed. This type of control scheme is used for remote or inaccessible installations such as water-treatment plants or pumping stations. In these applications it is desirable to have an immediate return to service when power is restored.

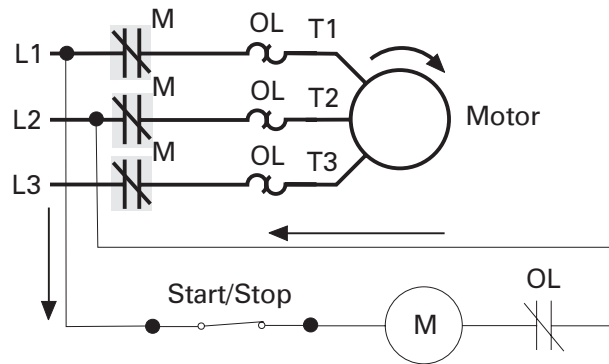

Selector Switches

Selector switches are also used to manually open and close contacts. Selector switches can be maintained, spring return or key operated. Selector switches are available in two-, three-, and four-position types. The basic difference between a push button and a selector switch is the operator mechanism. With a selector switch the operator is rotated to open and close contacts. Contact blocks used on pushbuttons are interchangeable with those used on selector switches. Selector switches are used to select one of several circuit possibilities such as manual or automatic operation, low or high speed, up or down, right or left, and stop or run. The Siemens 22 mm and 30 mm selector switches can handle up to a maximum of 10 circuits. The Furnas selector switch can handle up to a maximum of 16 circuits.

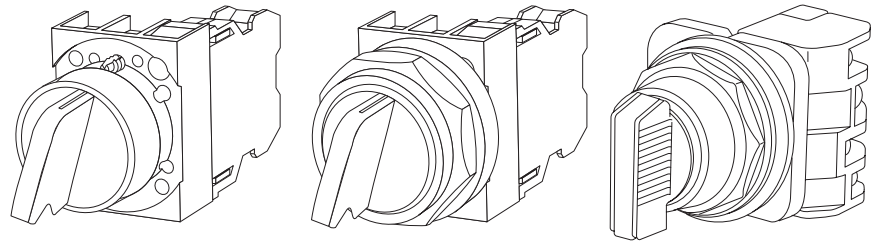

Siemens
22 mm Diameter
Selector Switch

Siemens
30 mm Diameter
Selector Switch

Furnas
30 mm Class 52
Selector Switch

Two Position Selector Switch

In the following example PL1 is connected to the power source when the switch is in position 1. PL2 is connected to the power source when the switch is in position 2. In this circuit either PL1 or PL2 would be on at all times. If there were only one load, then the selector switch could be used as an On/Off switch.

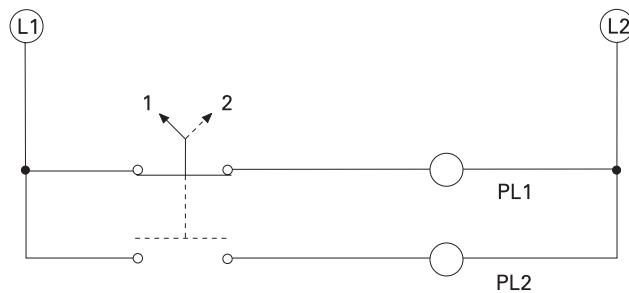

Contact Truth Tables

There are two accepted methods of indicating contact position of a selector switch in a circuit. The first method uses solid and dashed lines to denote contact position as shown in the previous example. In the second method truth tables, also known as target tables, are used. Each contact is marked with a letter. An "X" in the truth table indicates which contacts are closed for a given switch position. In this example contact A is closed, connecting PL1 to the power source, when the switch is in position 1. Contact B is closed, connecting PL2 to the power source, when the switch is in position 2.

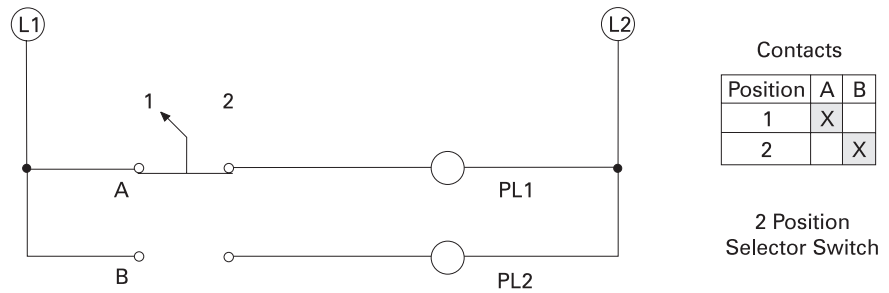

Three-Position

A three-position selector switch can be used to select either of two sets of contacts or to disconnect both sets of contacts. Hand/Off/Auto is a typical application for a three-position selector switch used for controlling a pump. In the Hand (manual) position the pump will start when the Start pushbutton is pressed. The pump can be stopped by switching the stop button to the Off position. The liquid level switch has no effect in either the Hand or Off position. When the selector switch is set to Auto, the pump will be controlled by the liquid-level switch. At a predetermined level the liquid level switch closes, starting the pump. At a predetermined level the liquid level switch opens, stopping the pump.

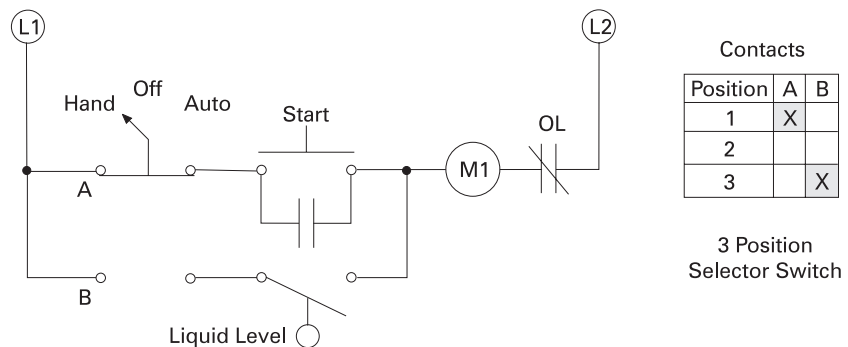

Pilot Lights

Pilot lights provide visual information at a glance of the circuit's operating condition. Pilot lights are normally used for "ON/OFF" indication, caution, changing conditions, and alarm signaling.

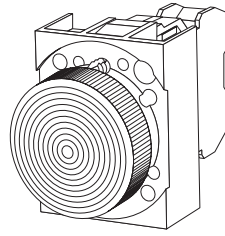

Siemens
22 mm Diameter
Pilot Light

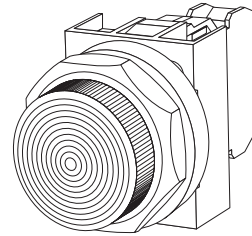

Siemens
30 mm Diameter
Pilot Light

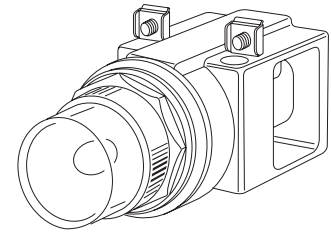

Furnas
30 mm Class 52
Pilot Light

Pilot lights come with a color lens, such as red, green, amber, blue, white, or clear. A red pilot light normally indicates that a system is running. A green pilot light normally indicates that the system is off or deenergized. For example, a red pilot light located on a control panel would give visual indication that a motor was running. A green pilot light would give visual indication that a motor was stopped.

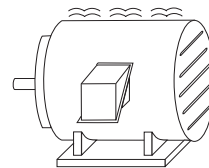
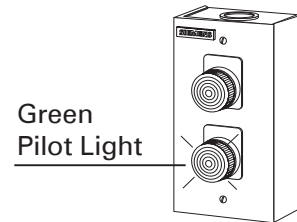
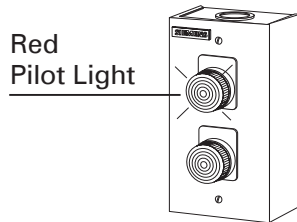

Motor
Running

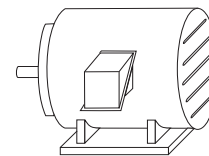

Motor
Stopped

Using a Pilot Light in a Control Circuit

In the following line diagram, a red pilot light is connected in parallel with the "M" electromagnetic coil.

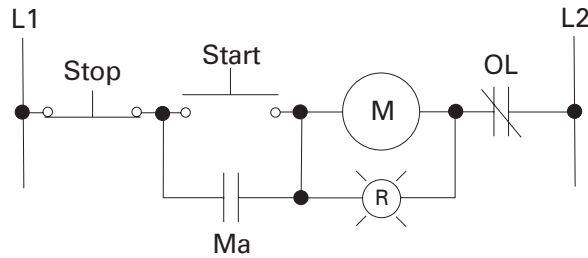

When the coil is energized, the light will illuminate to indicate the motor is running. In the event the pilot light burns out the motor will continue to run.

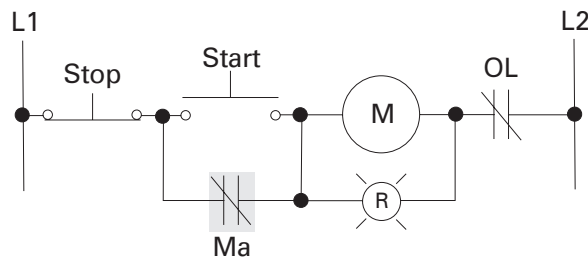

In the following line diagram a green pilot light is connected through a normally closed "M" auxiliary contact (Mb). When the coil is deenergized, the pilot light is on to indicate the motor is not running.

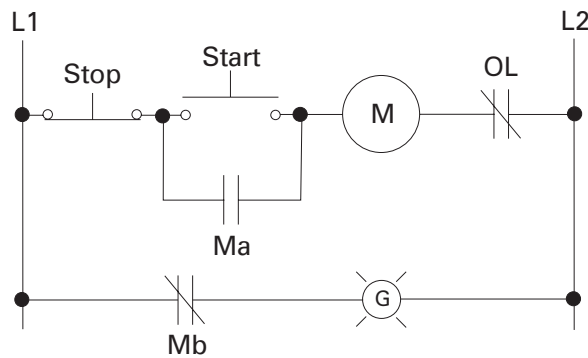

Depressing the “Start” pushbutton and energizing the “M” contactor opens the normally closed “Mb” contacts, turning the light off.

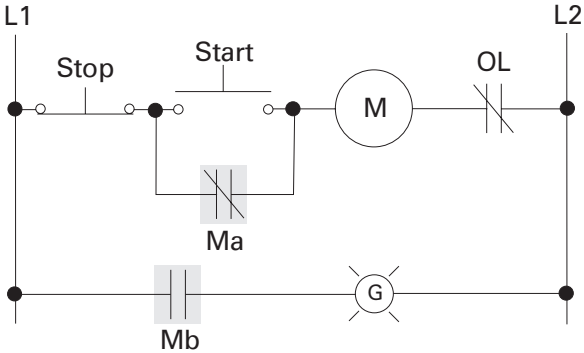

8WD43 Signalling Columns

Signalling columns can be mounted locally on individual machines, making it possible for the operating personnel to monitor production stations from a distance. Individual modules, or elements, are connected together. Various visual elements are available, including strobe lights, steady or flashing lights, and incandescent or LED lights. Lenses for the light elements are available in red, yellow, green, blue, and clear. Audible elements include a siren and a buzzer. In addition, a communication element is available allowing the signalling column to communicate with PLCs or computers through the Actuator Sensor Interface (ASI) network. Up to 10 elements can be used on a signalling column.

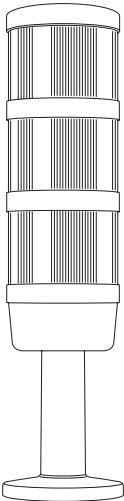

Review 7

1. A _____ _____ directs the operation of another device.
2. Which of the following circuits represents a two-wire control and which represents a three-wire control?

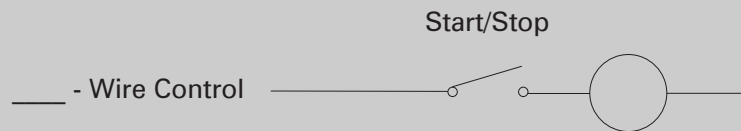
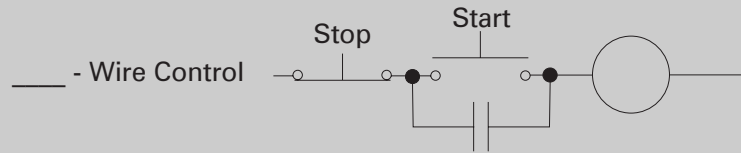

3. Pilot lights provide _____ information of the circuit's operating condition.
4. A _____ pilot light normally indicates a motor is running and a _____ pilot light normally indicates a motor is stopped.

Control Transformers

It is often desirable to operate the control circuit at a lower voltage than the power circuit. Control transformers are used to step a voltage down to a lower level. Siemens control transformers are available in various primary and secondary voltages from 50 to 5000 VA.

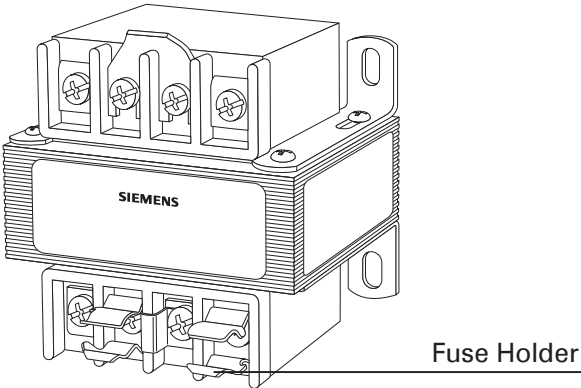

In the following example, the power circuit is 460 VAC. A control transformer is used to step the voltage down to 24 VAC for use in the control circuit. The electromagnetic coil voltage must be rated for 24 VAC. Fuses on the primary and secondary windings of the transformer provide overcurrent protection.

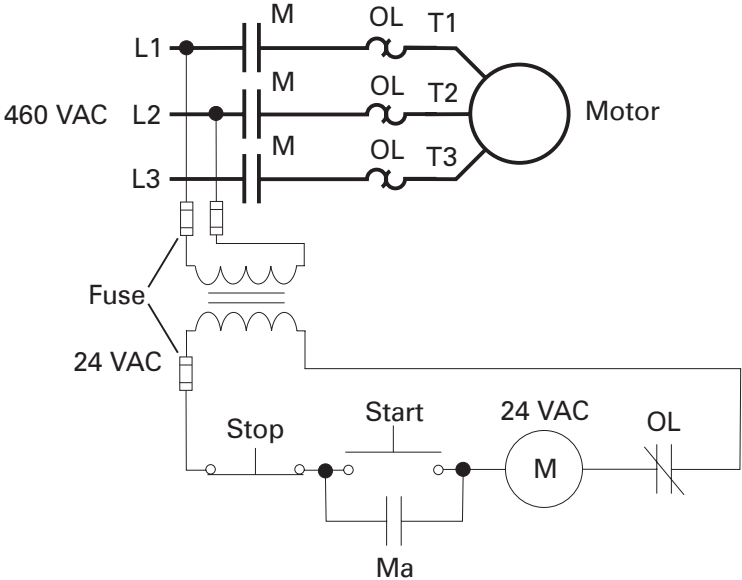

Control Relays

Relays are widely used in control circuits. They are used for switching multiple control circuits and for controlling light loads such as starting coils, pilot lights, and audible alarms.

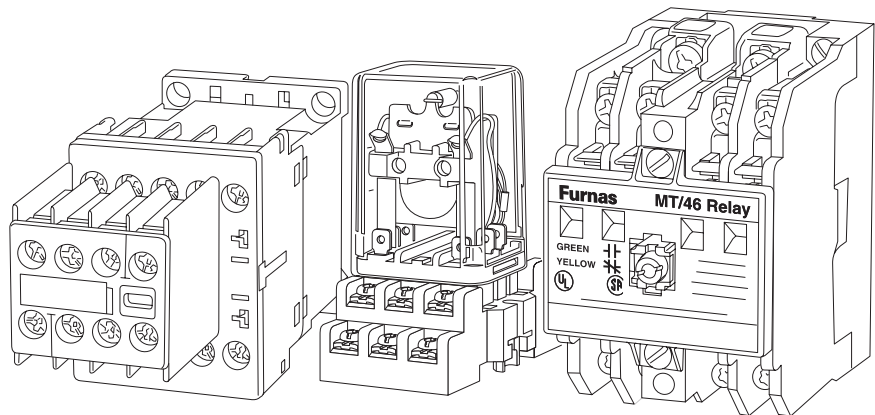

Relay Operation

The operation of a control relay is similar to a contactor. In the following example a relay with a set of normally open (NO) contacts is used. When power is applied from the control circuit, an electromagnetic coil is energized. The resultant electromagnetic field pulls the armature and movable contacts toward the electromagnet closing the contacts. When power is removed, spring tension pushes the armature and movable contacts away from the electromagnet opening the contacts.

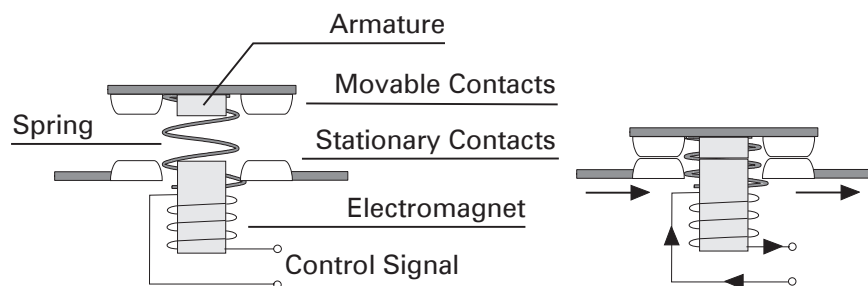

Contact Arrangement

A relay can contain normally open, normally closed, or both types of contacts. The main difference between a control relay and a contactor is the size and number of contacts. The contacts in a control relay are relatively small because they need to handle only the small currents used in control circuits. There are no power contacts. Also, unlike a contactor, each contact in a control relay controls a different circuit. In a contactor, they all control the starting and stopping of the motor. Some relays have a greater number of contacts than are found in the typical contactor. The use of contacts in relays can be complex. There are three words which must be understood when dealing with relays.

Pole

Pole describes the number of isolated circuits that can pass through the relay at one time. A single-pole circuit can carry current through one circuit. A double-pole circuit can carry current through two circuits simultaneously. The two circuits are mechanically connected so that they open or close at the same time.

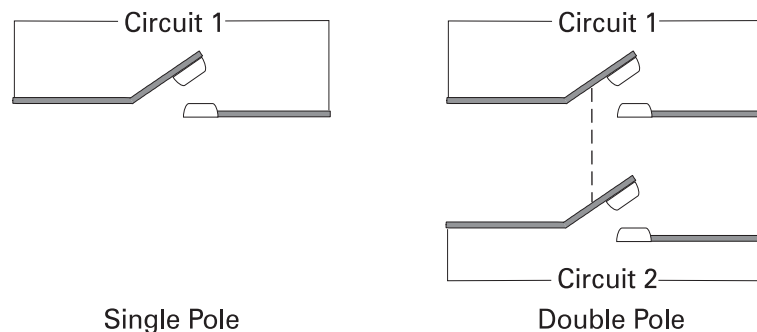

Throw

Throw is the number of different closed-contact positions per pole. This is the total number of different circuits each pole controls.

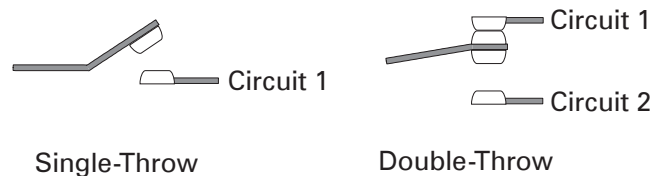

The following abbreviations are frequently used to indicate contact configurations:

- SPST Single-Pole, Single-Throw
- SPDT Single-Pole, Double-Throw
- DPST Double-Pole, Single-Throw
- DPDT Double-Pole, Double-Throw

Break

Break is the number of separate contacts the switch contacts use to open or close individual circuits. If the switch breaks the circuit in one place, it is a single-break. If the relay breaks the circuit in two places, it is a double-break.

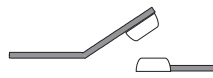

Single-Break

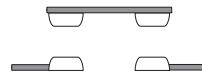

Double-Break

The following illustrates various contact arrangements.

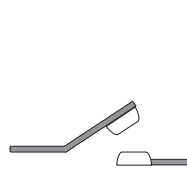

Single-Pole
Single-Throw
Single-Break

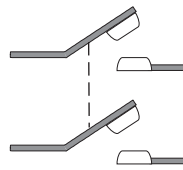

Double-Pole
Single-Throw
Single-Break

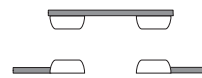

Single-Pole
Single-Throw
Double-Break

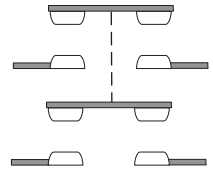

Double-Pole
Single-Throw
Double-Break

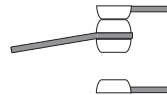

Single-Pole
Double-Throw
Single-Break

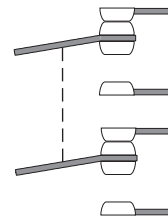

Double-Pole
Double-Throw
Single-Break

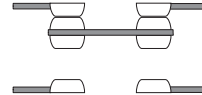

Single-Pole
Double-Throw
Double-Break

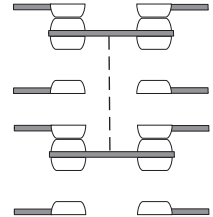

Double-Pole
Double-Throw
Double-Break

Interposing a Relay

The following line diagram illustrates one way a control relay might be used in a circuit. A 24 VAC coil may not be strong enough to operate a large starter. In this example the electromagnetic coil of the "M" contactor selected is rated for 460 VAC. The electromagnetic coil of the control relay (CR) selected is 24 VAC. This is known as interposing a relay.

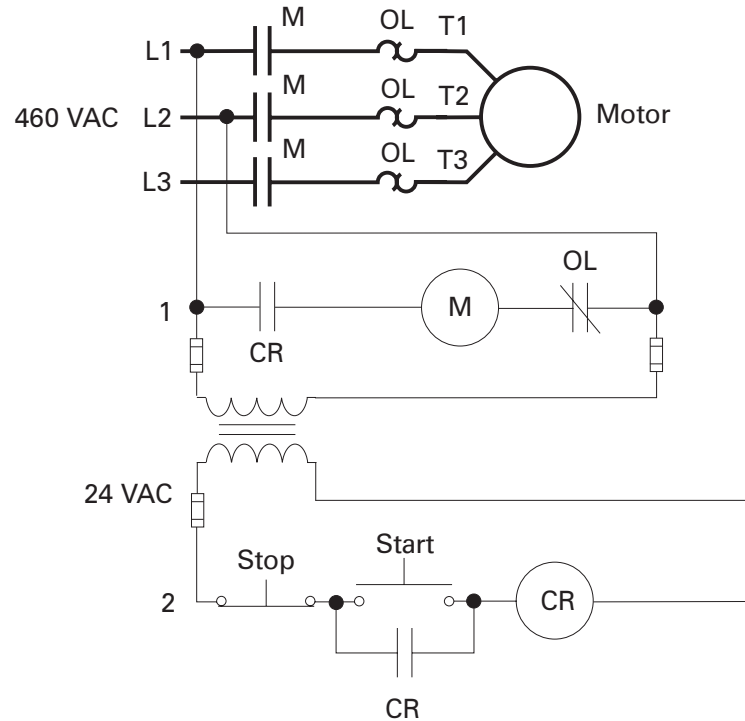

When the "Start" pushbutton in line 2 is momentarily depressed, power is supplied to the control relay (CR).

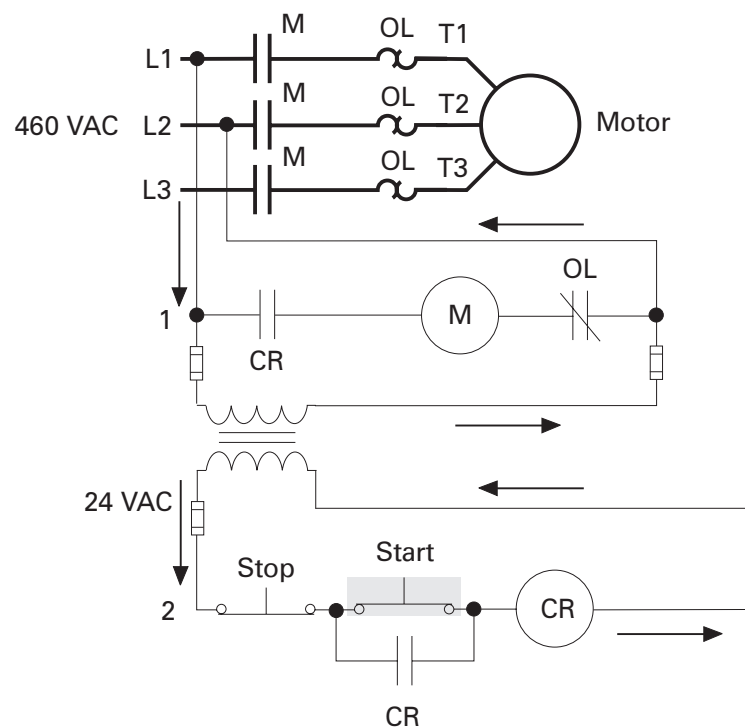

The "CR" contacts in lines 1 and 2 close. The "CR" contacts in line 2 maintain the start circuit. The "CR" contacts in line 1 complete the path of current to the "M" motor starter. The "M" motor starter energizes and closes the "M" contacts in the power circuit, starting the motor. Depressing the "Stop" pushbutton deenergizes the "CR" relay and "M" motor starter.

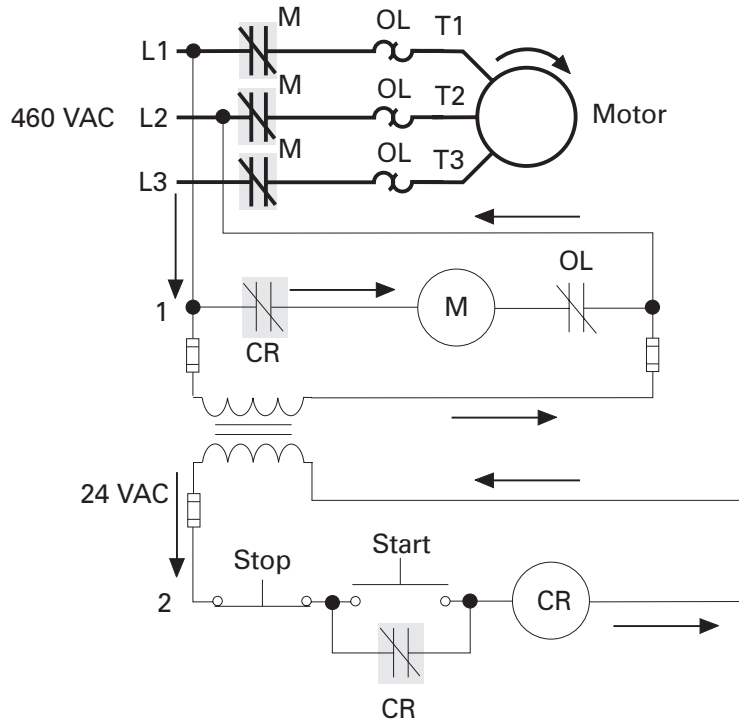

Sirius 3RH11 Control Relays

Siemens has a complete line of industrial-control relays. Sirius 3RH11 relays are available with screw terminal or Cage Clamp. The screw terminal version is shown in the following illustration. Four contacts are available in the basic device. Four additional contacts in the form of a snap-on device can be added to the front of the relay. Some Sirius 3RH11 relays are specifically designed to interface directly with PLCs and other solid-state control devices. Sirius 3RH11 relays are rated for switching both AC and DC circuits. Coil voltages range from 12 VDC to 230 VDC and 24 VAC to 600 VAC.

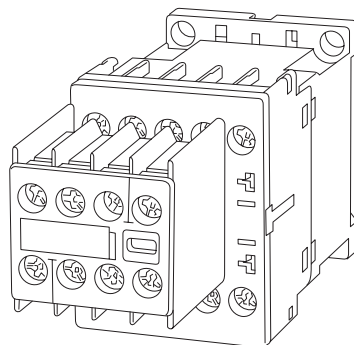

Class 46 Machine-Tool Relay

Furnas Class 46 machine-tool relays are available with coil voltages from 12 VDC to 250 VDC, and 24 VAC to 600 VAC. Relays with two, three, or four poles may be expanded up to eight poles with an adder deck. Standard, gold flashed, and overlapping contacts are rated at 10 amperes. Master contacts are rated at 20 amperes.

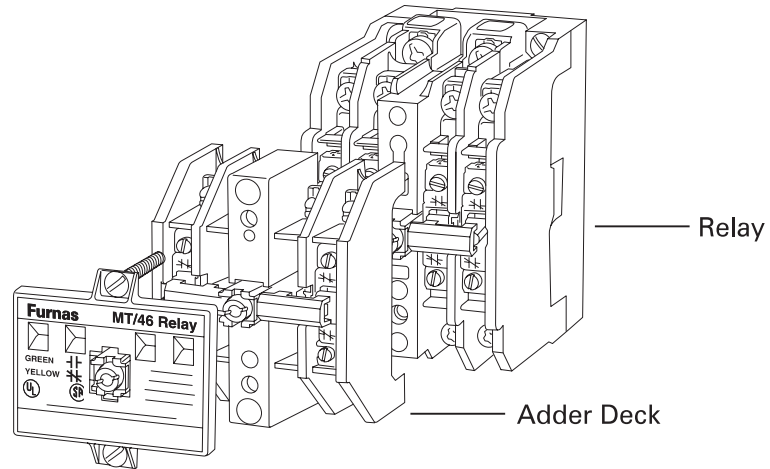

Class 46 machine-tool relay contacts can be field changed between normally open (NO) and normally closed (NC).

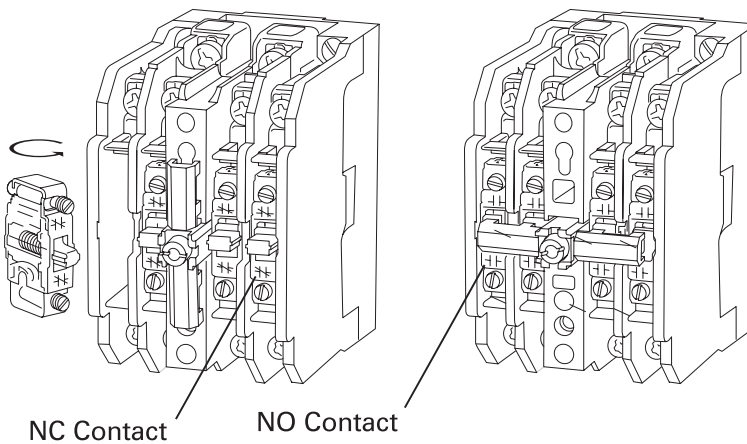

Class 46 Industrial-Control Relays

Class 46 industrial-control relays are used in a wide variety of applications including assembly, packaging, and material handling systems. The basic unit consists of four poles, but additional top-mounted adder decks and snap on side mounts allow for a maximum of 12 poles per relay. Class 46 relays are available with coil voltages up to 600 VAC.

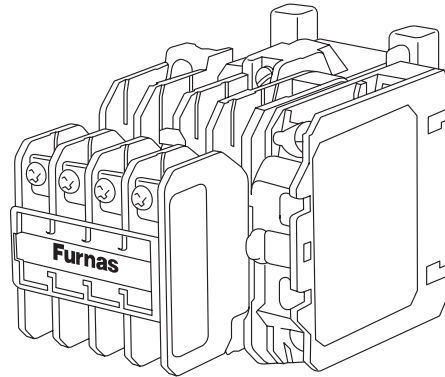

General-Purpose Relays (Plug-In Relays)

Siemens also manufactures a variety of general-purpose relays for socket and flange mounting. Coil voltages are available in 24 VAC, 120 VAC or 24 VDC. The biggest benefit of this type of relay is all the wiring stays in place with the socket if the relay needs to be replaced with a new one.

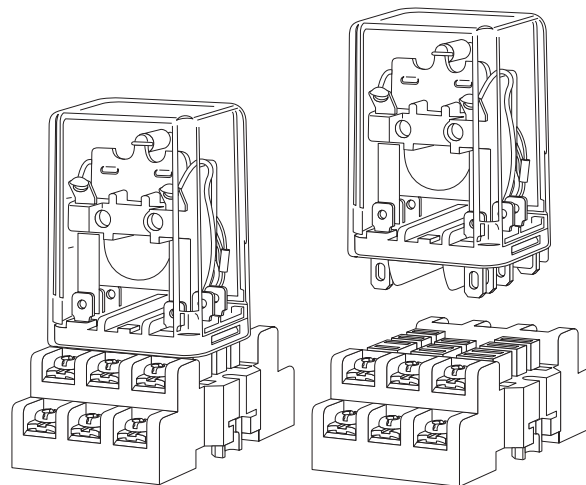

Timing Relays

Timing relays, such as the Sirius 3RP timing relays, are used in control switching operations involving time delay. Sirius 3RP1 timing relays have timing ranges available from .05 seconds to 10 hours. Sirius 3RP15 have timing ranges from .05 seconds to 100 hours.

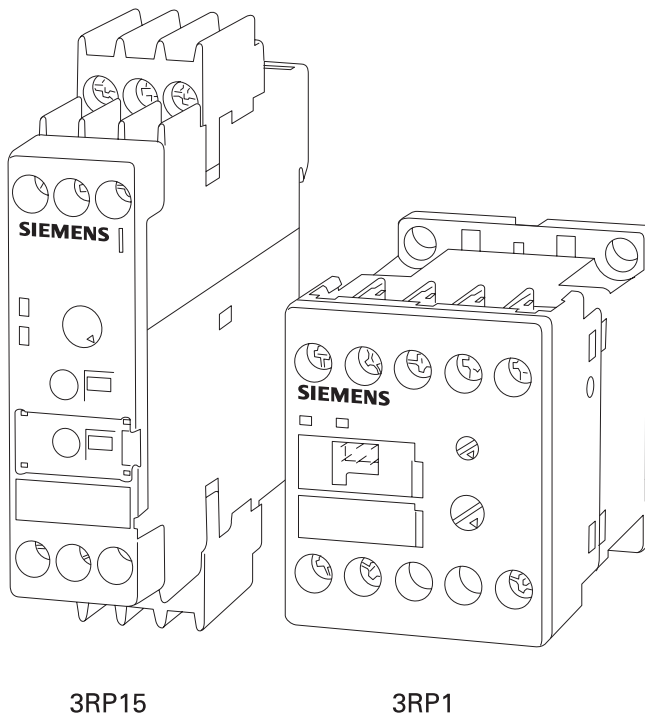

Time Delay

A timing relay has two major functions: On-delay and Off-delay timing. An arrow is used to denote the function of the timer. An arrow pointing up indicates an On-delay timing action. An arrow pointing down indicates an Off-delay timing action.

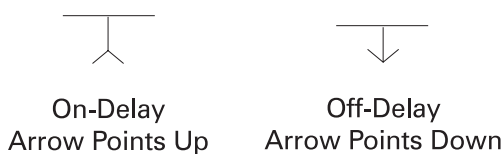

On-delay and Off-delay timers can turn their connected loads on or off, depending on how the timer's output is wired into the circuit. On-delay indicates that once a timer has received a signal to turn on, a predetermined time (set by the timer) must pass before the timer's contacts change state. Off-delay indicates that once a timer has received a signal to turn off, a predetermined time (set by the timer) must pass before the timer's contacts change state.

On-Delay, Time Closed

The following is an example of On-delay, timed closed. For this example a set of normally open (NO) contacts is used. This is also referred to as normally open timed closed (NOTC). The timing relay (TR1) has been set for an On-delay of 5 seconds.

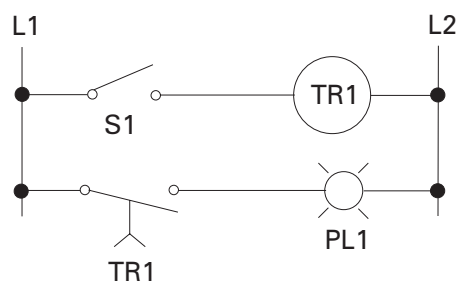

When S1 is closed, TR1 begins timing. When 5 seconds has elapsed, TR1 will close its associated normally open (NO) TR1 contacts, illuminating pilot light PL1. When S1 is open, deenergizing TR1, the TR1 contacts open immediately, extinguishing PL1.

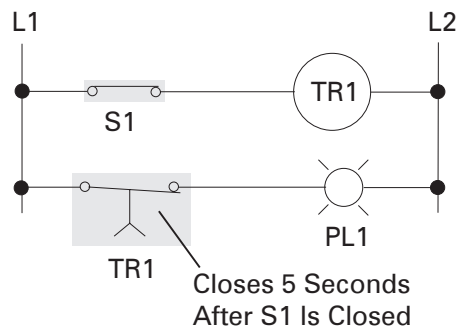

On-Delay, Timed Open

The following is an example of On-delay, timed open. For this example a set of normally closed (NC) contacts is used. This is also referred to as normally closed, timed open (NCTO). PL1 is illuminated as long as S1 remains open. The timing relay (TR1) has been set for an ON delay of 5 seconds.

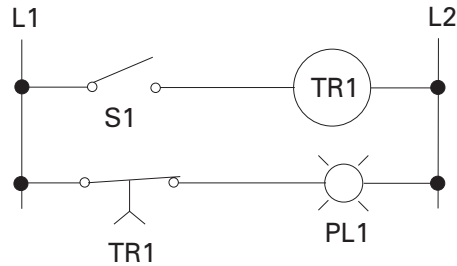

When S1 is closed, timing relay TR1 is energized. After a timed delay of 5 seconds, the associated normally closed TR1 contacts open, extinguishing PL1. When S1 is open, deenergizing TR1, the TR1 contacts close immediately, illuminating PL1.

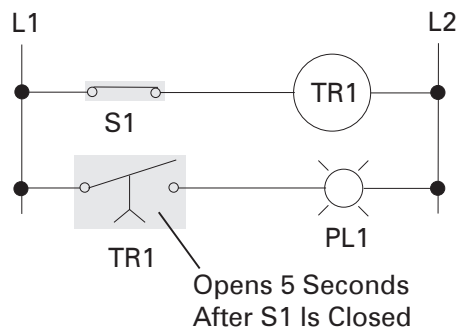

Off-Delay, Timed Open

The following is an example of Off-delay, timed open. For this example a set of normally open contacts (NO) is used. This is also referred to as normally open, timed open (NOTO). The timing relay (TR1) has been set for an off delay of 5 seconds. Closing S1 energizes TR1 causing its associated normally open TR1 contacts to close immediately, illuminating PL1.

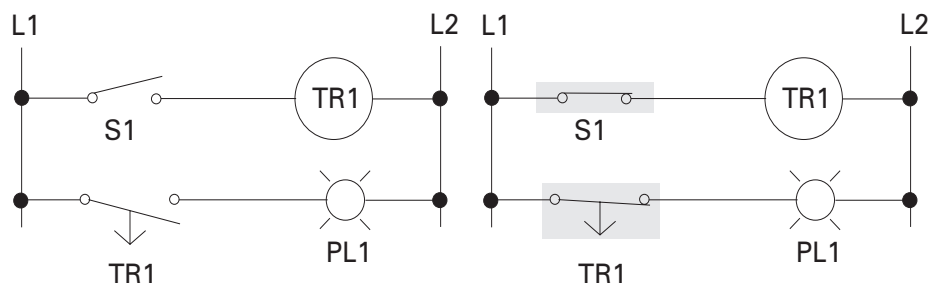

When S1 is opened, TR1 begins timing. When 5 seconds has elapsed, TR1 will open its associated normally open contacts, extinguishing pilot light PL1.

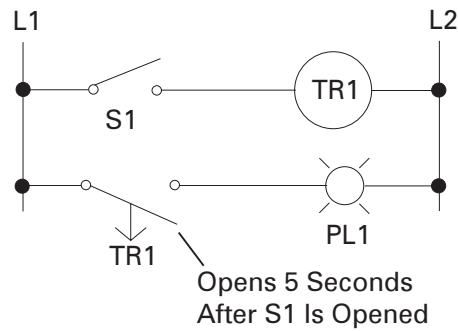

Off-Delay, Timed Closed

The following is an example of Off-delay, timed closed. For this example a set of normally closed (NC) contacts is used. This is also referred to as normally closed, timed closed (NCTC). The timing relay (TR1) has been set for 5 seconds. PL1 is on. Closing S1 energizes TR1 causing its associated contacts to open immediately, extinguishing PL1.

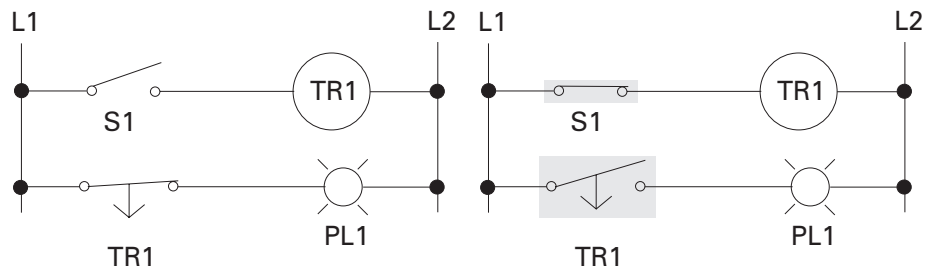

When S1 is opened, timing relay TR1 is deenergized. After 5 seconds, the associated normally closed contacts close, illuminating PL1.

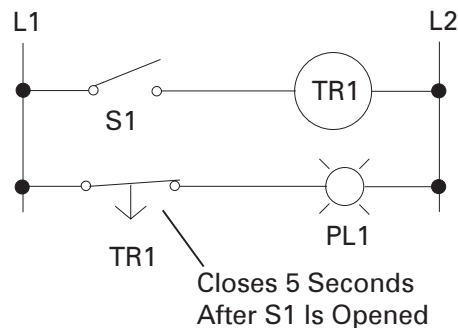

Instantaneous Contacts

Timing relays can also have normally open or normally closed instantaneous contacts. In the following example, when switch S1 is closed, the TR1 instantaneous contacts will close immediately, illuminating PL1. After a preset time delay the TR1 timing contacts will close, illuminating PL2.

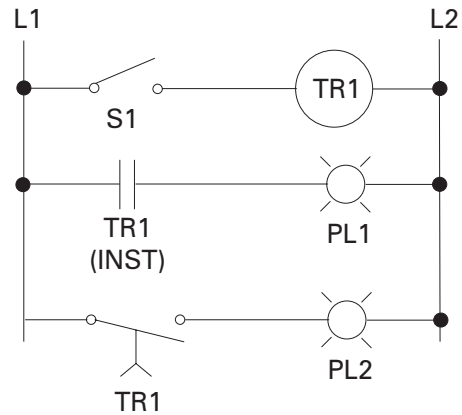

Review 8

1. _____ is the total number of different circuits each pole controls.
2. _____ describes the number of isolated circuits that can pass through a relay at one time.
3. An SPDT relay has _____ pole(s) and _____ closed contact position(s).
4. A timing relay that has received a signal to turn on, and then delays a predetermined amount of time before an action takes place is referred to as _____ delay.

Limit Switches

Position-Sensing Devices

One type of feedback that is frequently needed by industrial-control systems is the position of one or more components of the operation being controlled. Position-sensing devices provide information on the presence or absence of an object by opening or closing an electrical circuit. This information is used to determine when to start, stop, reverse, slow down or speed up a process. Siemens position-sensing devices include limit switches, photoelectric control, inductive and capacitive proximity switches, and ultrasonic sensors. TAG (Technical Application Guides) sheets for sensing devices are available from your Siemens sales representative.

Limit Switches

One type of position-sensing device is a limit switch. The standard limit switch is mechanical and uses physical contact to detect the presence of an object. When the object to be detected comes in contact with the actuator (lever), it moves the actuator to a point where the mechanical contacts change state. Through this action an electrical circuit is energized or de-energized. When the object no longer makes contact with the actuator, the mechanical contacts return to their original state, either opened or closed. This is a momentary operation.

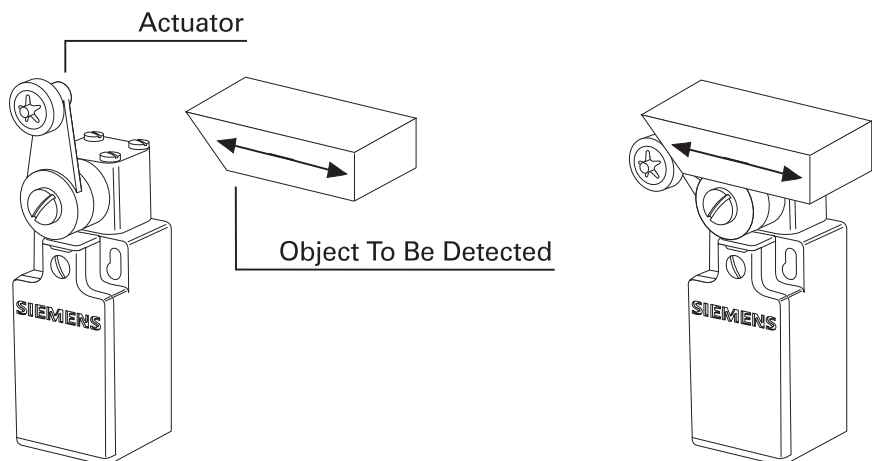

Limit Switch Used in a Control Circuit

In the following diagram, a limit switch (LS1) has been placed in series with the "M" contactor. The motor has been started and is running.

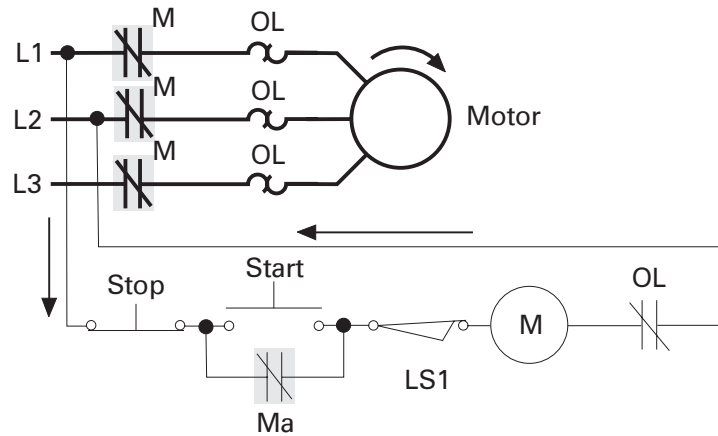

When the object to be detected comes in contact with the actuator, the limit switch will open. The "M" contactor is de-energized and the motor stops. The motor can be manually restarted when the object is no longer in contact with the actuator and the limit switch is closed.

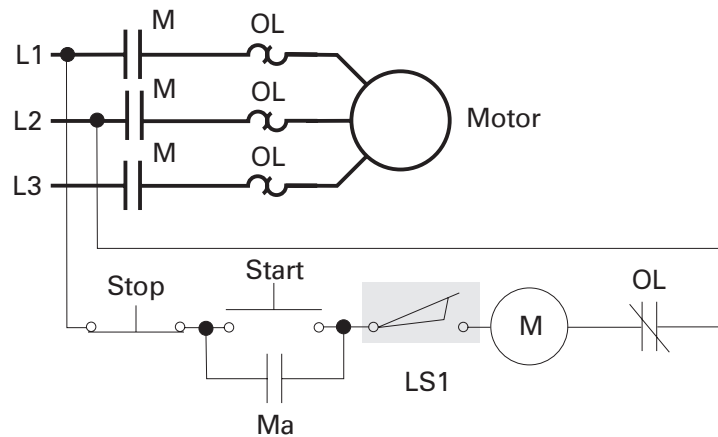

Principle of Operation

The limit switch design in the following illustration uses an actuator to move a set of movable contacts to a set of stationary contacts. A number of positions must be considered when an object comes in contact with the actuator arm.

The free position is the position of the actuator when no external force is applied.

Pretravel is the distance or angle traveled in moving the actuator from the free position to the operating position.

The operating position is where contacts in the limit switch change from their normal state (NO or NC) to their operated state.

Overtravel is the distance the actuator can travel safely beyond the operating point.

Differential travel is the distance traveled between the pretravel and the release position.

The release position is where the contacts change from their operated state to their normal state.

Release travel is the distance traveled from the release position to the free position.

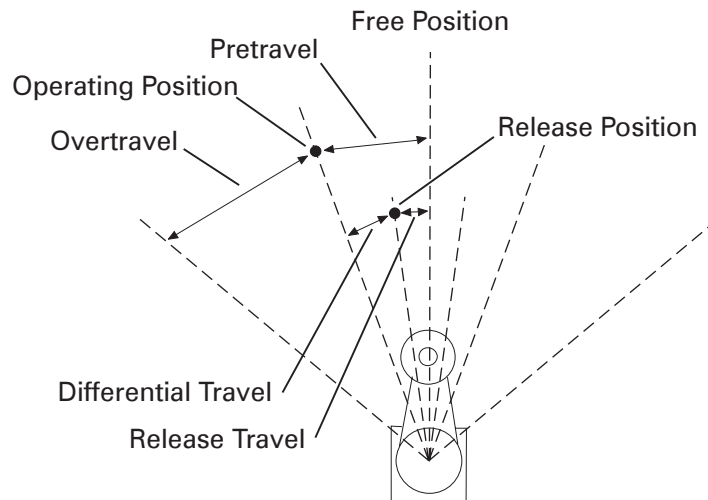

Types of Actuators

Several styles of limit switches and actuators are available, some of which are shown below. The contacts of a momentary switch return from their operated state to their normal state when the operating force is removed. There is also a maintained switch. The actuator is typically a “fork” design. The actuator and mechanical contacts remain in the operated state after the operating force is removed. The actuator and mechanical contacts return to their original state when an operating force is applied in the opposite direction. Limit switches are also available with slow-action contacts or snap-action contacts. The speed of the slow-action contact make/break action is dependent on the speed of the actuator. The speed of the snap-action contact make/break action is independent of the operating speed.

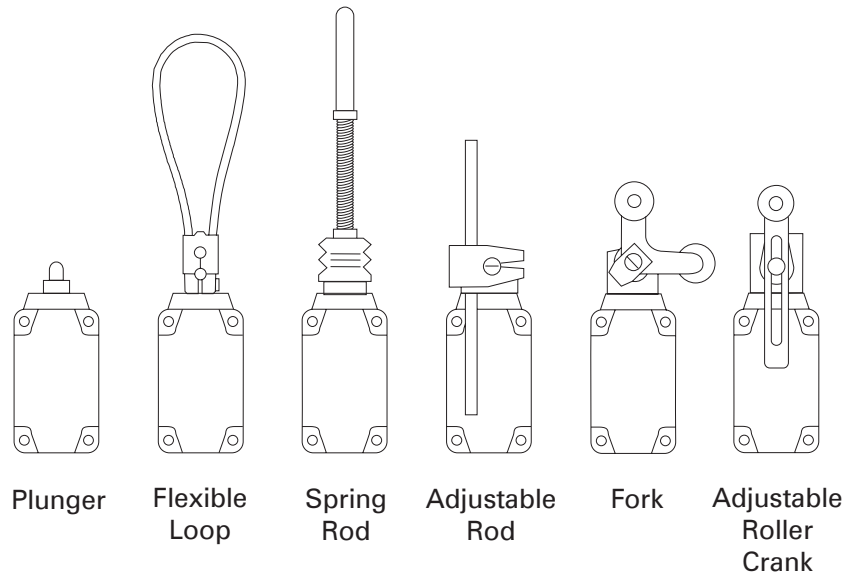

For more information on mechanical limit switches refer to TAG CP1403.

Pressure Switches

Pressure switches are control devices that respond to changes in pressure of liquid or air. The liquid or air is referred to as fluid pressure. They open or close electrical contacts in response to pressure changes by either turning on or off a motor, opening or closing louvers, or signaling a warning light or horn. For loads up to 5 HP the pressure switches may handle the current directly. For larger loads the pressure switch is used to energize relays, contactors, or motor starters, which then energize the load.

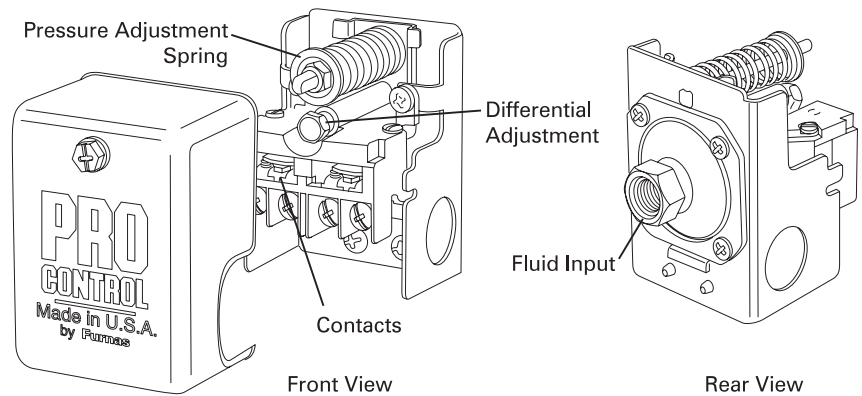

Pressure Switch Components

The basic components of a pressure switch are illustrated below. Electrical contacts are operated by the movement of a diaphragm against the force of a spring. The contacts may be normally open (NO) or normally closed (NC). The spring setting determines how much fluid pressure is required to operate the contacts.

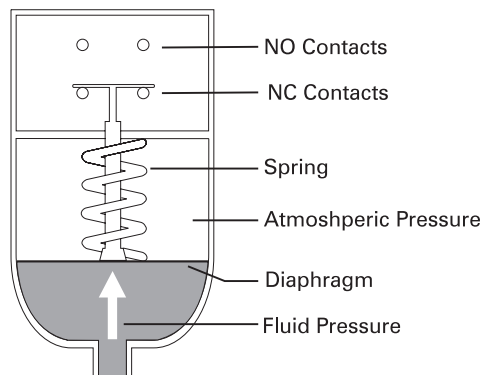

Application

Pressure switches are frequently used to maintain a specified pressure range in a storage tank. Storage tanks can be used to hold a liquid, such as water, or a gas, such as air.

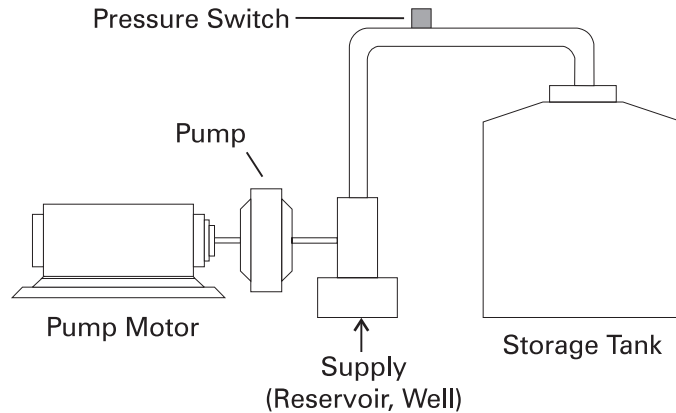

Operation

In this example a normally closed pressure switch is used. The pump starts as soon as power is applied to the circuit. When the pressure in the storage tank has reached a predetermined level, the contacts in the pressure switch open, removing power from the pump motor. As the contents of the storage tank are used, the pressure in the tank decreases. At a predetermined level the pressure switch will close its contacts, applying power to the pump motor.

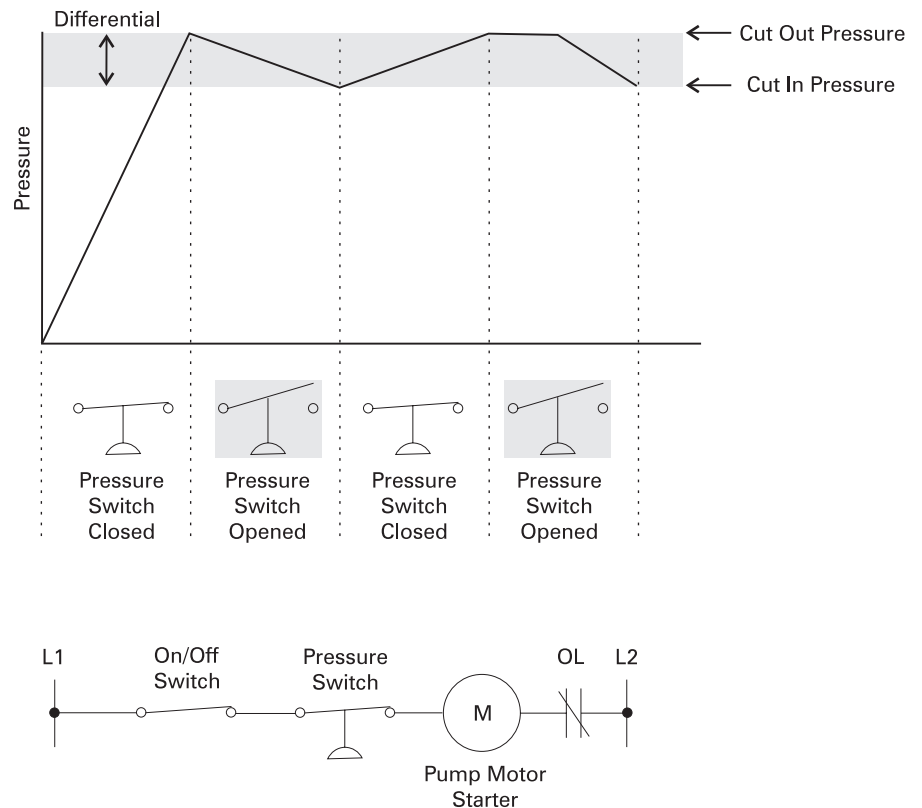

Pressure Range

Pressure switches are designed to operate within a specified pressure range, usually given in pounds per square inch (PSI). In the following example, a Furnas Class 69ES water pressure switch operates within a range of 10 to 80 PSI. The minimum close, or cut-in pressure, is 10 PSI. This is the point at which fluid pressure on the diaphragm causes the contacts to close. The maximum open, or cut-out pressure, is 80 PSI. This is the point at which fluid pressure on the diaphragm causes the contacts to open. Pressure differential is the difference between these two settings. The Furnas Class 69ES pressure switch can have a differential range of 15-25 PSI. In this example the cut-in pressure has been set to 30 PSI. The cut-out pressure has been set to 50 PSI. The pressure differential is 20 PSI. The pressure switch will regulate the pressure between 30 and 50 PSI.

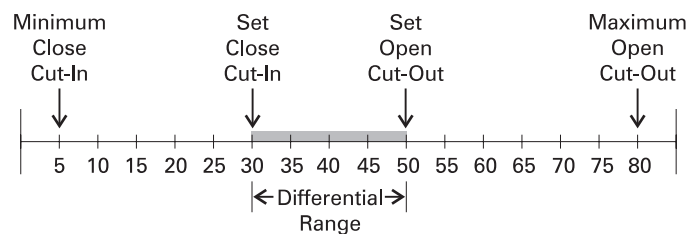

Reverse Action

Reverse action pressure switches cut-in on a rising pressure. They are designed to ground the ignition on gas engine driven pumps and compressors when the maximum pressure has been reached. In the following example a Furnas Class 69WR5 reverse action pressure switch has been selected. The 69WR5 has a minimum open (cut-out) of 10 PSI and a maximum close (cut-in) of 80 PSI. The differential is set so that the switch opens at 30 PSI and closes at 50 PSI.

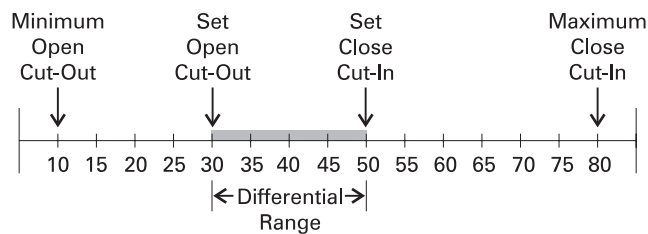

Photoelectric Control

A photoelectric sensor is another type of position sensing device. Photoelectric sensors, similar to the one shown below, use a modulated infrared light beam that is either broken or reflected by the object to be detected. The control consists of an emitter (light source), a receiver to detect the emitted light, and associated electronics that evaluate and amplify the detected signal causing the photoelectric's output switch to change state. Unlike limit switches, photoelectric sensors operate without physical contact (no touch control).

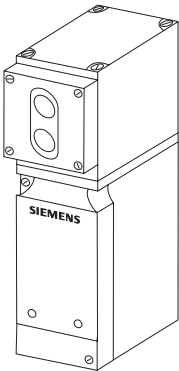

Limit Switch
Style Housing

Thru Scan

A scan technique is a method used by photoelectric devices for detecting objects. There are two basic scan techniques, thru scan and reflective scan. Thru scan is also referred to as beam break, thru beam, transmitted beam, and opposed. Light from an emitter is transmitted in a straight line to a separate receiver. The receiver converts the light into electrical energy. An object placed in the path of the light beam blocks the light from the emitter causing the receiver's output to change state. When the object no longer blocks the light path, the receiver's output returns to its normal state. The maximum sensing range is 300 feet.

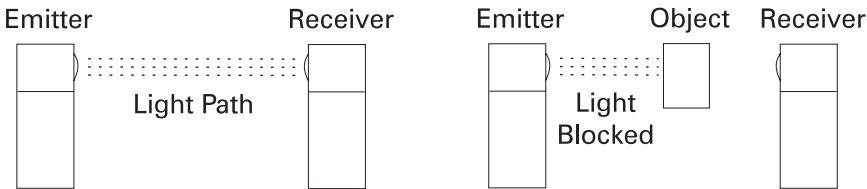

A photoelectric sensing device, for example, might be positioned over a roll of paper. When the roll on the winder reaches a predetermined diameter, it will interrupt the light beam and automatically stop the motor.

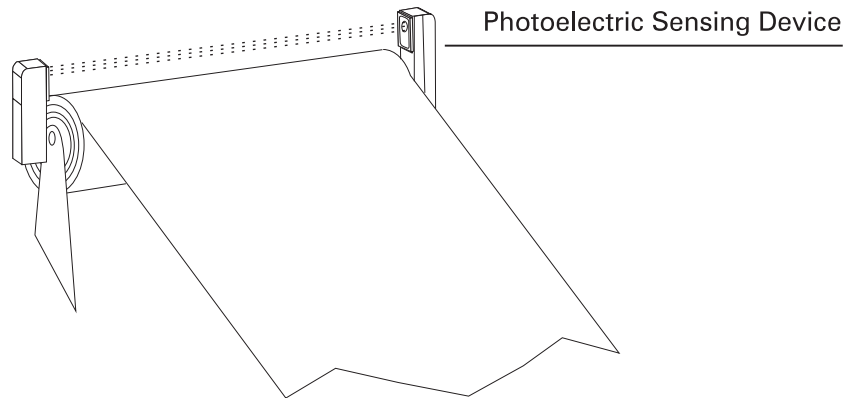

Reflective Scan

Reflective scan is also referred to as retroreflective. The photoelectric sensor contains both the emitter and the receiver. Light from the emitter is transmitted in a straight line to a retroreflective target and returns to the receiver along the same optical axis. When an object blocks the path of light, the output changes state. When the object no longer blocks the light path, the output returns to its normal state. The maximum sensing range is 35 feet.

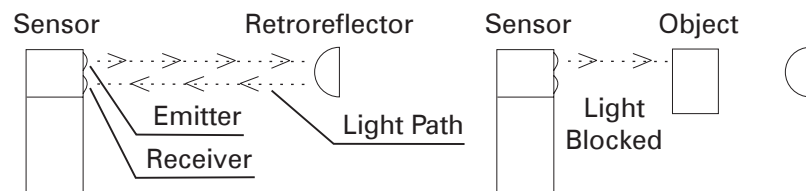

Polarized Reflective Scan

A variation of reflective scan is polarized reflective scan. Polarizing filters are placed in front of both the emitter and receiver lens. The filters are oriented such that the planes of orientation are at 90 degrees to one another. The emitted light is polarized horizontally. Reflected light from a corner cube retroreflector is depolarized sufficiently to allow reflected light to pass through the polarizing filter into the receiver. Light reflected from a shiny surface is not depolarized and the reflected light is blocked from entering the receiver by the polarizing filter. The maximum sensing range is 15 feet.

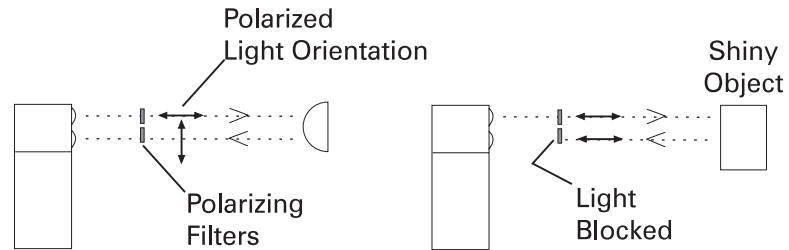

Diffuse Reflective Scan

Another reflective technique is diffuse reflective. Light from the emitter strikes the object to be detected and the light is diffused from the surface of the object at all angles. If the receiver receives enough reflected light, the load will energize. When no light is reflected back to the receiver, the load returns to its original state. The maximum sensing range is 40 inches.

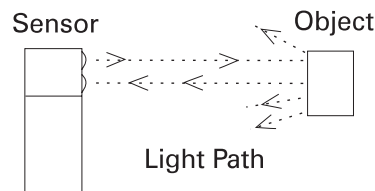

Operating Modes

There are two basic operating modes, dark operate (DO) and light operate (LO). Dark operate is an operating mode in which the load is energized when light from the emitter is absent from the receiver.

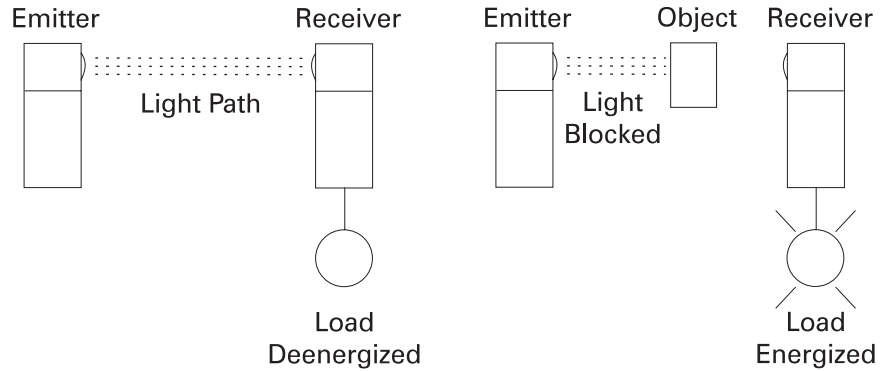

Light operate is an operating mode in which the load is energized when light from the emitter reaches the receiver.

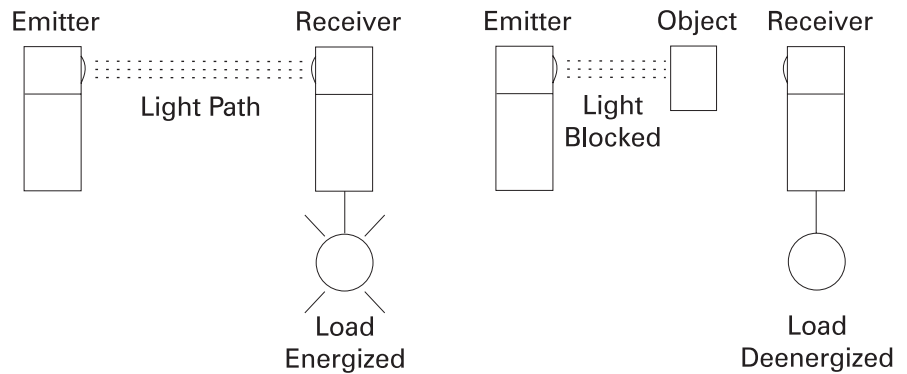

The following chart shows the relationship between the operating mode and load status:

Operating Mode	Light Path	Load Status	
		Thru Scan and Retroreflective	Diffuse Reflective
Light Operate (LO)	Not Blocked	Energized	Deenergized
	Blocked	Deenergized	Energized
Dark Operate (DO)	Not Blocked	Deenergized	Energized
	Blocked	Energized	Deenergized

Fiber Optics

Fiber optics is not a scan technique, but another method for transmitting light. The maximum sensing distance is 25.5 inches. Fiber optics can be used with thru scan, reflective scan, or diffuse reflective scan depending on the fiber optic cable selected.

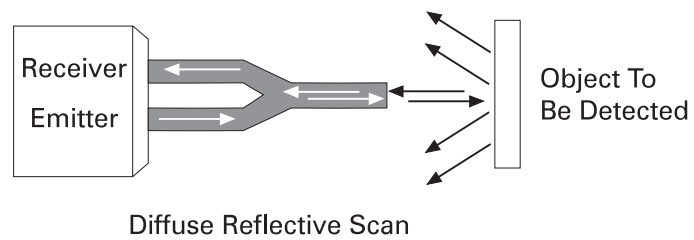
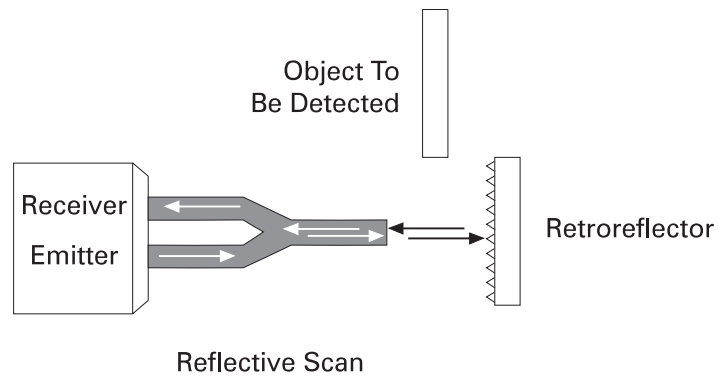
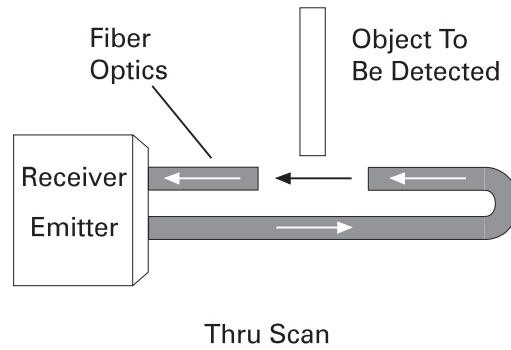

Review 9

1. The part of the limit switch the object to be detected comes in contact with is known as the _____ .
2. _____ is the distance the actuator travels from the free position to the operating position.
3. The liquid or air pressure that operates against the diaphragm of a pressure switch is referred to as _____ pressure.
4. _____ _____ is a scan technique using a separate emitter and receiver in which, when an object blocks a light beam, the sensor's output changes state.
5. When light from the emitter is absent from the receiver and the receiver's output changes state, the switch is operating in the _____ _____.
6. _____ _____ is an operating mode in which the load is energized when light from the emitter is incident on the receiver.

Inductive Proximity Switches

Another type of position sensing device is the inductive proximity switch. The Siemens line of proximity switches carries the trademark BERO[®] which stands for **B**ounce-free **E**ddy current **R**adio frequency **O**scillator. Unlike limit switches, inductive proximity switches require no physical contact with the object to be detected.

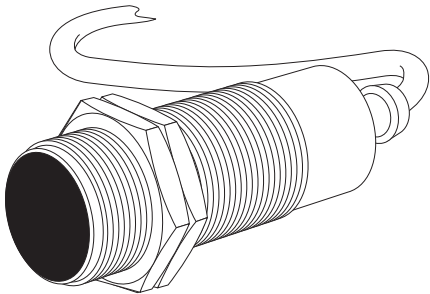

Inductive Proximity Switches

Inductive proximity switches only detect conductive metal objects. An electromagnetic field emanates from the sensing face to detect the presence or absence of a metal object. When a metal object enters the field, the object is detected and the output switch changes state. When the object leaves the electromagnetic field, the output switch returns to its original state. Depending on the device, inductive proximity switches have a maximum sensing range of 2.5 inches.

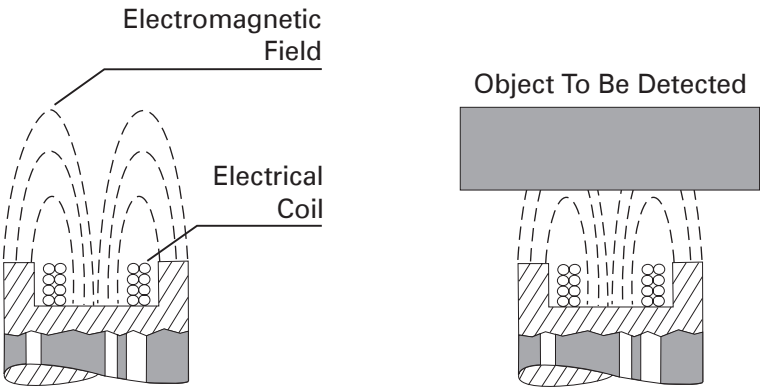

Mounting

Depending on the specific device, there are two ways inductive proximity switches are mounted. Some devices are shielded and may be embedded in metal flush with their sensing face without adversely affecting their sensing characteristics. Other devices are unshielded and require a free zone around their sensing face.

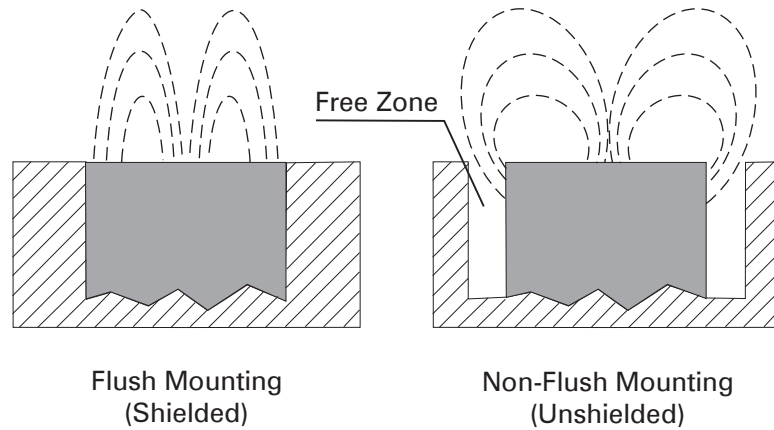

Response Characteristic

Proximity switches respond to an object only when it is in a defined area in front of the switch's sensing face. The shape of this response area is called the response characteristic of the switch.

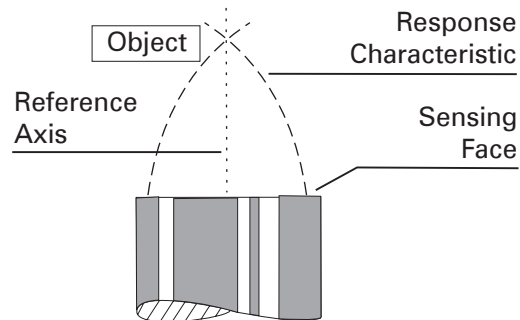

The point at which the proximity switch recognizes an incoming object is the operating point. The point at which an outgoing object causes the device to switch back to its normal state is called the release point. The area between these two points is called the hysteresis zone.

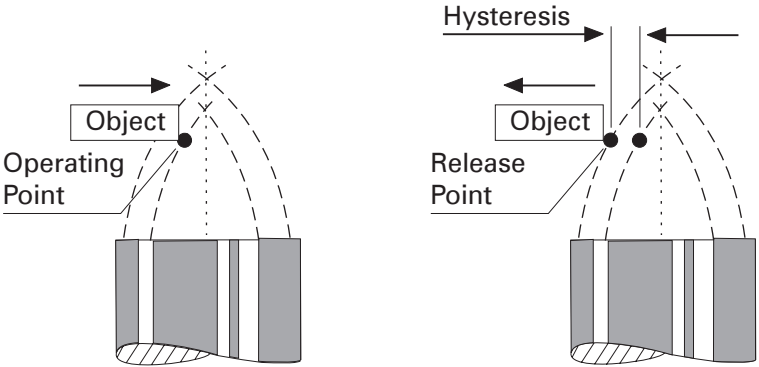

Response Curve

The size and shape of the response characteristic varies with the size and shape of the switch. The following graph shows the response characteristic of one type of proximity switch.

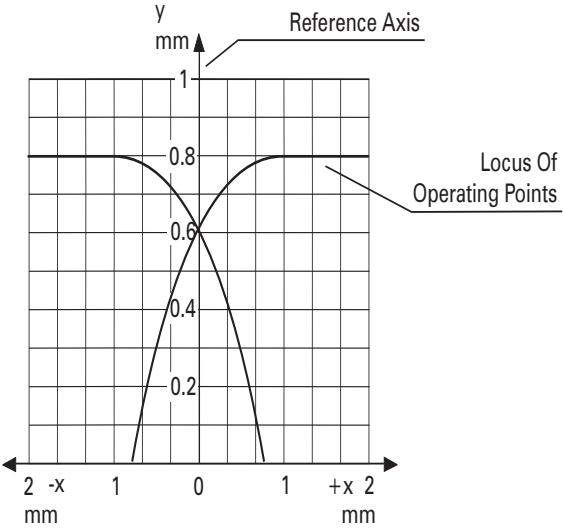

Categories

Inductive proximity switches are available in eight categories from standard duty to submersible. They are also available in various sizes and styles. Refer to Siemens Pricing and Selection Guide, PC8000, for the description and application of each type.

Output

Siemens inductive proximity switch product lines include AC, DC and AC/DC (universal voltage) models. Direct current models are typically three-wire devices requiring a separate power supply.

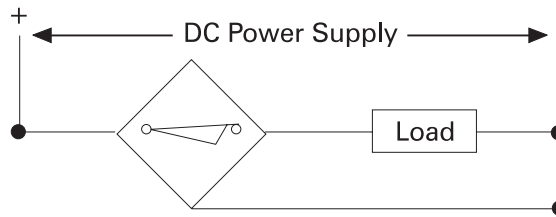

Normally Closed (NC) Current Sourcing Switch

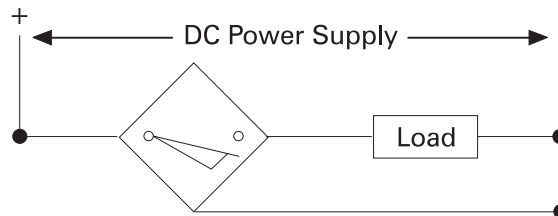

Normally Open (NO) Current Sourcing Switch

Some DC models and universal-voltage models are two-wire devices which can be used with DC or AC circuits. A separate power supply is also required. These models can be connected to such control devices as contactors because of their ability to produce output currents up to 500 milliamps, and they can also be used with programmable controllers.

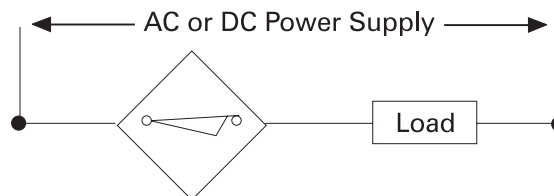

Normally Closed (NC) Switch

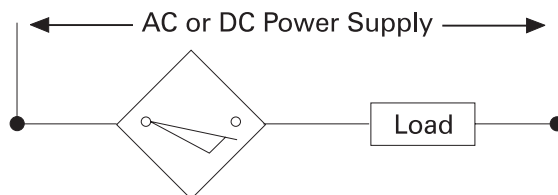

Normally Open (NO) Switch

Applications

Inductive proximity switches have a number of uses. In this example, an inductive proximity switch is used for counting or sorting bottles by detecting the metal bottle cap.

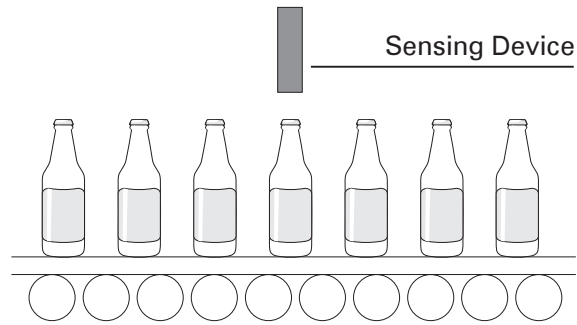

Short switching times allow it to perform high-speed counting for speed monitoring.

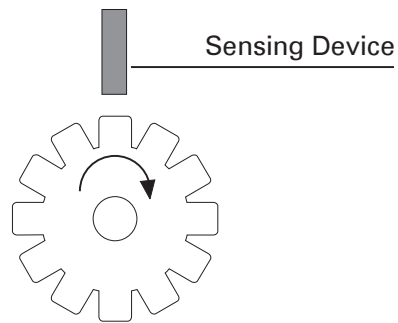

Capacitive Proximity Switches

Capacitive proximity switches are similar to inductive proximity switches. The main difference between the two types is that a capacitive proximity switch produces an electrostatic field instead of an electromagnetic field. Capacitive proximity switches will sense metal and also nonmetallic materials such as paper, glass, liquids, and cloth.

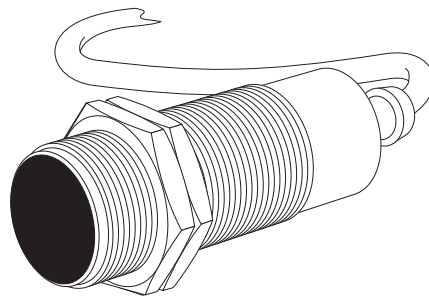

Best Suited For Nonconductive Material

There are two types of capacitive sensors: best suited for nonconductive materials and best suited for conductive materials. Capacitive proximity switches best suited for nonconductive materials can be used with materials such as glass, plastic, cloth, wood, and paper. This type of sensor will also detect conductive material. Care must be taken to ensure that this type of sensor is used in a dry environment. Liquid on the sensing surface could cause the sensor to operate. These devices may be flush mounted without adversely affecting their sensing characteristics.

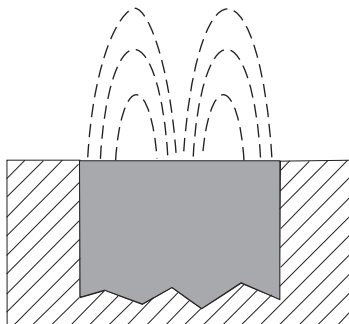

Best Suited For
Non-Conductive Materials

**Best Suited For
Conductive Material**

Capacitive proximity switches best suited for conductive material can be used with materials such as copper, aluminum, brass, steel, and conductive fluids. Formation of liquid on the sensing surface is generally not a problem. These devices require a free zone around the sensing face.

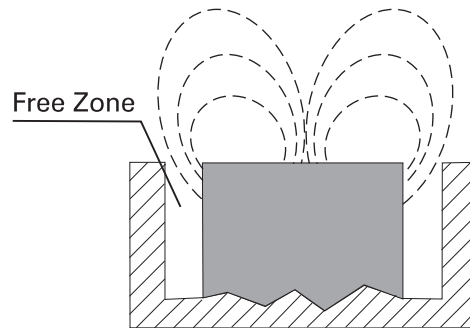

Best Suited For
Conductive Materials

**Detection Through
a Barrier**

One application for capacitive proximity switches is liquid level or solid level detection. For example, a proximity switch could be used to detect the liquid or solid level of material inside a barrier or container.

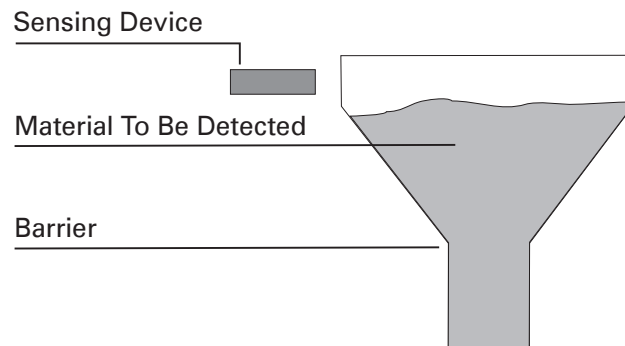

The following chart illustrates the proper capacitive proximity switch when detecting material through a barrier.

Barrier Material	Material To Be Detected	Sensor Type (1)
Nonconductive	Conductive	A
	Nonconductive	B
Conductive	Conductive	(2)
	Nonconductive	(2)

(1) A = Best Suited For Conductive Materials
 B = Best Suited For Nonconductive Materials

(2) Reposition the capacitive proximity switch directly over the material to be detected and use sensor type A, or use a tank well to penetrate through the barrier and use sensor type B.

Correction Factors

Sensing distance varies with different types of material to be detected. The rated operating distance for a specific sensor is given in the PC8000 catalog. To determine the actual sensing distance, multiply the rated operating distance times the correction factor for the material selected. The following chart gives typical correction factors.

Material	Best Suited For Nonconductive Materials	Best Suited For Conductive Materials
Steel, Grounded 1 mm Thick	1.0	1.0
Glass 3 mm Thick	0.7	0.4
PVC 3 mm Thick	0.6	0.1
Cardboard 2 mm Thick	0.4	0.1
Wood 10 mm Thick	0.5	0.25
Water In Grounded Tank	1.0	0.75

For example, if the rated operating distance for a best suited for nonconductive sensor is 15 mm, and the material to be detected is glass, the sensing distance is 10.5 mm (15 x 0.7).

Ultrasonic Sensors

Ultrasonic sensors use a transducer to send and receive high frequency sound signals. When an object to be detected enters the beam, the sound is reflected back to the switch, causing it to energize or deenergize the output circuit.

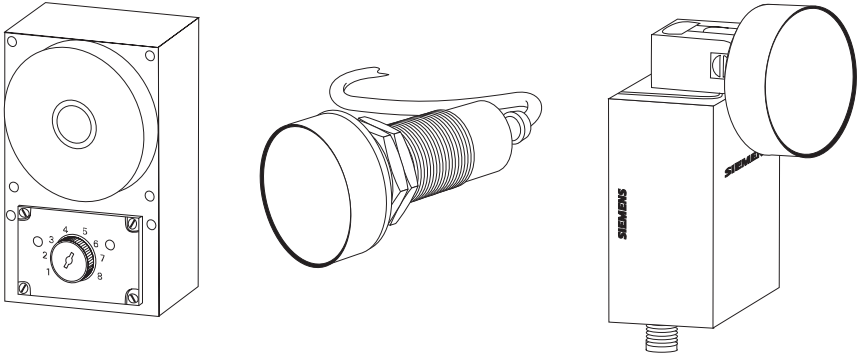

Principle of Operation

The SONAR-BERO[®] uses a piezoelectric ceramic disk which can transmit and receive high-frequency pulses. A high-frequency voltage is applied to the disk, causing it to vibrate at the same frequency. The vibrating disk produces high-frequency sound waves. When transmitted pulses strike a sound-reflecting object, echoes are produced. These echoes are received by the transducer and transformed into electrical signals. When the object to be detected enters the preset operating range, the output of the switch changes state. When the object leaves the preset operating range, the output returns to its original state.

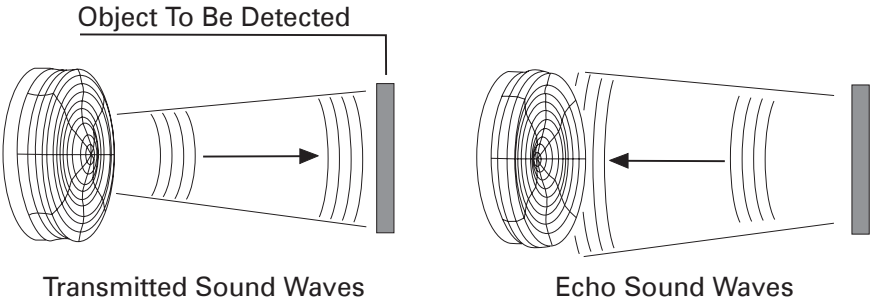

Applications

Typical applications for the SONAR-BERO include level sensing, spacing and height differentiations, object sensing, and counting. In the following example a sensing device detects the height and spacing of packages on a conveyor.

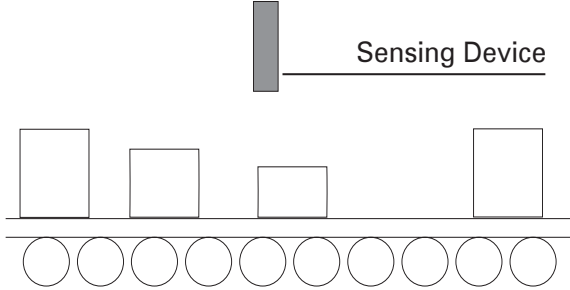

LOGO! Logic Module

LOGO! is a logic module used to perform control tasks. The module is compact and user friendly, providing a cost-effective solution for the end user.

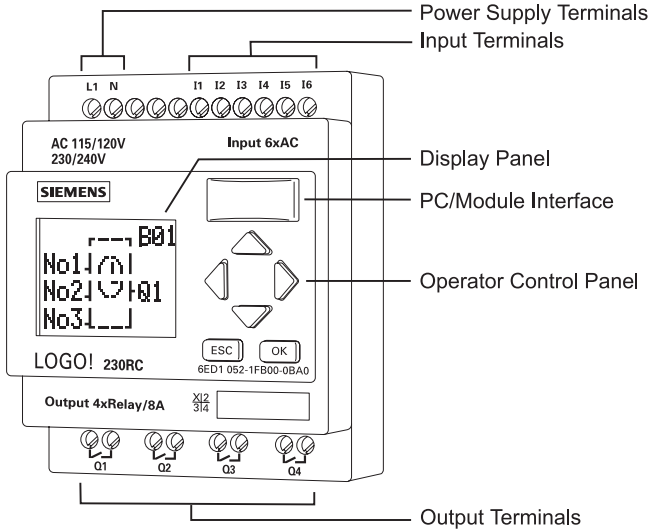

Hard-Wired Control

In the past, many of these control tasks were solved with contactor or relay controls. This is often referred to as hard-wired control. Circuit diagrams had to be designed and electrical components specified and installed. A change in control function or system expansion could require extensive component changes and rewiring.

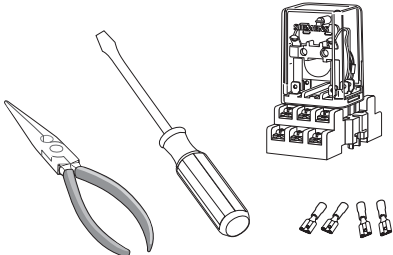
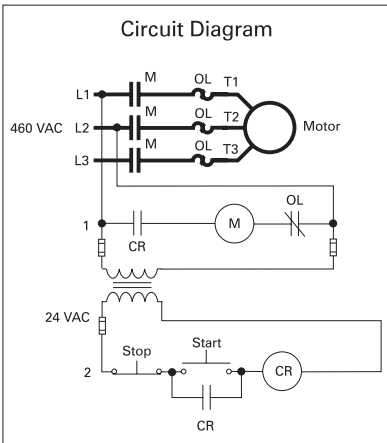

Many of the same tasks can be performed with LOGO!. Initial hard-wiring, though still required, is greatly simplified. Modifying the application is as easy as changing the program via the keypad located on the front of the LOGO!. Likewise, control programs can be created and tested before implementation via a PC software program. Once the program is performing per specification, the transfer to LOGO! is as simple as plugging in a cable.

Basic LOGO! Operation

LOGO! accepts a variety of digital inputs, such as pushbuttons, switches, and contacts. LOGO! makes decisions and executes control instructions based on the user-defined program. The instructions control various outputs. The outputs can be connected to virtually any type of load such as relays, contactors, lights, and small motors.



Design Features

LOGO! is available in many different versions for different supply voltages (12 VDC, 24 VDC, or 115/230 VAC).

All models have:

- Relay outputs with maximum 8 amp or 10 amp output current (not LOGO! 24/24L models)
- Integrated display
- Integrated keypad
- Integrated basic and special functions
- Integrated EEPROM for storing programs and setpoints
- Optional program module
- Basic AND, OR, NOT, NAND, NOR, and XOR functions
- Special ON delay, latching ON delay, OFF delay, pulse relay, latching relay, clock pulse generator, and counter (up/down) functions

The basic versions feature:

- Six digital inputs, four digital outputs
- Integral clock (LOGO! 230RC, 24RC)

The L models feature:

- Twelve digital inputs, eight digital outputs
- Four additional inputs and outputs on the AS-interface modules
- Impulse relay
- Elapsed time meter
- Six-digit counter (instead of four-digit counter)
- Retentivity for counters, operating-hours counter, impulse relay, and latching in conjunction with the optional program module with retentivity
- "Know-how" protection with the optional program module for copy protection and retentivity

Review 10

1. Inductive proximity switches can only detect _____ objects.
2. The point at which the proximity switch recognizes an incoming object is the _____ point.
3. _____ proximity switches can be used to detect metal objects and nonconductive objects.
a. Inductive b. Capacitive
4. A type of proximity switch which uses a transducer to send and receive high-frequency sound signals is the _____ proximity switch.





Review Answers

- Review 1** 1) manually; 2) a; 3) b; 4) b; 5) c.
- Review 2** 1) left to right; 2) A - Node, B - Power Wiring, C - Power Load, D- Control Wiring; E - Control Device; F - Control Load.
- Review 3** 1) a; 2) excess; 3) overload; 4) a; 5) bimetal.
- Review 4** 1) 2; 2) LVP; 3) 10, 5; 4) 20; 5) motor starter.
- Review 5** 1) NEMA, IEC; 2) 5; 3) AC3; 4) 4; 5) 3; 6) 50; 7) 3UA66.
- Review 6** 1) Consequent-pole motor; 2) progressive control; 3) reduced-voltage starting; 4) Autotransformer; 5) Nordic.
- Review 7** 1) pilot device; 2) Three-Wire Control, Two-Wire Control; 3) visual; 4) red, green.
- Review 8** 1) Throw; 2) Pole; 3) one, two; 4) ON.
- Review 9** 1) actuator; 2) Pretravel; 3); fluid; 4) Thru Scan; 5) Dark Operate; 6) Light Operate.
- Review 10** 1) metal; 2) operate; 3) Capacitive; 4) ultrasonic

Final Exam

The final exam is intended to be a learning tool. The book may be used during the exam. A tear-out answer sheet is provided. After completing the test, mail in the answer sheet for grading. A grade of 70% or better is passing. Upon successful completion of the test a certificate will be issued.

Questions

- Contacts are shown on a line diagram in their _____ state.
 - normally closed
 - normally open
 - energized
 - deenergized
- A motor that is running would usually be indicated by a _____ pilot light.
 - green
 - red
 - amber
 - white
- Which of the following symbols represents a normally closed, timed open (NCTO) contact?
 - 
 - 
 - 
 - 
- With an increase of current, temperature will _____ .
 - decrease
 - increase
 - remain the same
 - increase and decrease
- The two circuits involved in the operation of a contactor are the _____ circuits.
 - power and control
 - power and armature
 - control and electromagnetic
 - control and starter

6. A motor starter is a combination of a/an _____ .
- a. electromagnet and armature
 - b. contactor and electromagnet
 - c. contactor and overload relay
 - d. overload relay and instantaneous contacts
7. Which of the following is not part of a contactor?
- a. armature
 - b. electromagnetic coil
 - c. overcurrent sensing device
 - d. stationary contacts
8. One reason reduced-voltage starting may be used to start a motor is to _____ .
- a. apply torque gradually
 - b. increase starting torque
 - c. get motor to full speed faster
 - d. run the motor at a lower speed
9. A type of speed selection control that requires the operator to manually increment through each speed step to get to the desired speed is _____ control.
- a. selective
 - b. compelling
 - c. progressive
 - d. consequent pole
10. The organization primarily concerned with the rating of contactors and starters used in many countries, including the U.S. is _____ .
- a. NEMA
 - b. UL
 - c. ICS
 - d. IEC
11. The proper overload relay for a World Series 3TF50 contactor is _____ .
- a. 3UA50
 - b. 3UA54
 - c. 3UA58
 - d. 3UA60
12. A device used to provide visual information of the circuit's operating condition is a _____ .
- a. pushbutton
 - b. selector switch
 - c. proximity switch
 - d. pilot light

19. In the following diagram, the motor will stop when _____.
- the "Stop" button is depressed
 - limit switch "LS1" opens
 - the motor overload contact opens
 - all of the above

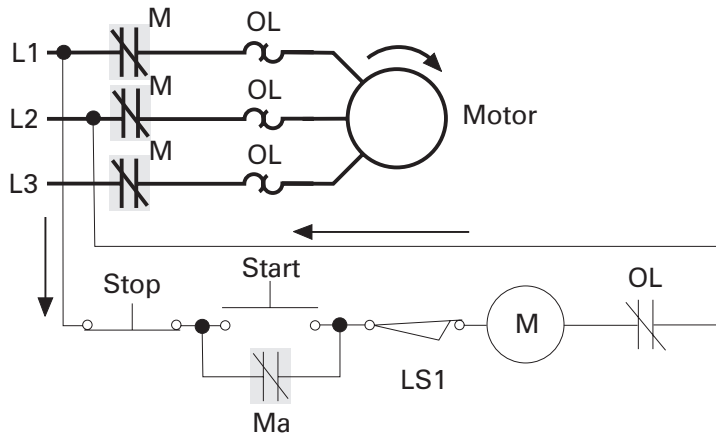

20. If the rated operating distance for a best suited for nonconductive sensor is 15 mm and the material to be detected is wood, the sensing distance is _____ mm.
- | | |
|--------|---------|
| a. 15 | b. 10.5 |
| c. 7.5 | d. 6 |

Notes

Notes